

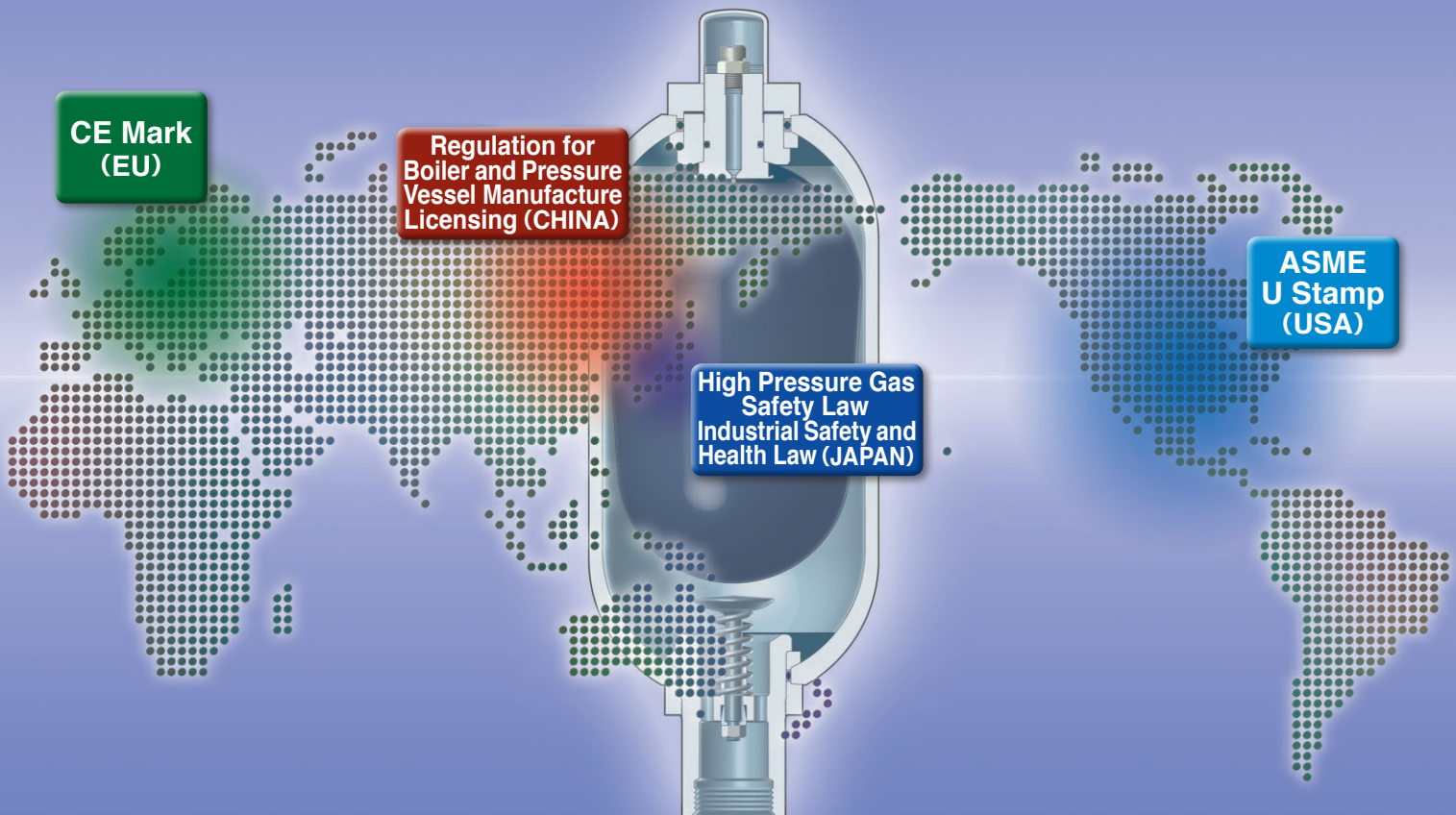

● Cat. No. 239E · 08-2014

Compliant with all major Regulations and Standards

ACCUMULATOR



ACCUMULATOR

NOK CORPORATION
EAGLE INDUSTRY CO., LTD.

The accumulators utilize the compressibility of gas. Feature greater energy efficiency, safety, and less noise.



NOK Accumulators have proved very popular with a number of customers as they are highly reliable with a wide ranging lineup available that are supported by global top-class rubber materials, seals and processing techniques, were designed with the environment taken into consideration, and are ISO14000 compliant.

ACCUMULATOR

NOK ACCUMULATOR

INDEX

Summary	1	Features and Structure of Accumulator	2
	2	Use of Accumulator	4
	3	Type of Accumulator	6
	4	Selection Procedure of Accumulator	8
	5	Accumulator Lists of Maximum Working Pressures and Volumes ...	9
List of Model Codes and Dimensions	6	NOK Accumulator Series Lists	10
	7	Minilator	12
	8	Diaphragm Type Accumulator	14
	9	Bladder Type Accumulator	16
	10	Transfer Barrier Type	29
	11	Piston Type Accumulator	30
	12	Expansion Tank	31
Accessories and Parts	13	Joint for Fluid Port Connecting (①Bushing, ②Flange)	32
	14	Accumulator Stop Valve	36
	15	TR Cap	37
	16	Gas Control Valve	38
	17	Gas-filling Tool (Charging Assembly)	40
	18	Fixing Band	43
	19	Assembly and Disassembly Tool	44
	20	Bladder Type Accumulator Replacement Kit	45
Handling and Selection	21	Accumulator Handling Precautions	54
	22	High Pressure Gas Safety Law and Procedure	56
	23	Accumulator Volume Calculation	58
	24	Attached Documents	67
		Accumulator Selection Request Volume Calculation Sheet Unit Conversion Table	

Summary

List of Model Codes and Dimensions

Accessories and Parts

Handling and Selection

1. Features and Structure of Accumulator

1. Features

The accumulators utilize the compressibility of gas.

Incorporating an accumulator with hydraulic equipment or other machinery that utilizes fluids can enable the accumulation of pressure which can then be used in momentarily supplying large volumes of fluid or absorbing pulses or impact pressure from pipes, while they can also play a significant role in improving the performance of equipment and machinery, including greater energy efficiency and less noise generation.

The accumulators can be divided into being of the membrane or piston type, depending on how the nitrogen gas is separated from the fluid.

- ◆ The following shows the operating states and structure of a representative bladder type membrane accumulator:

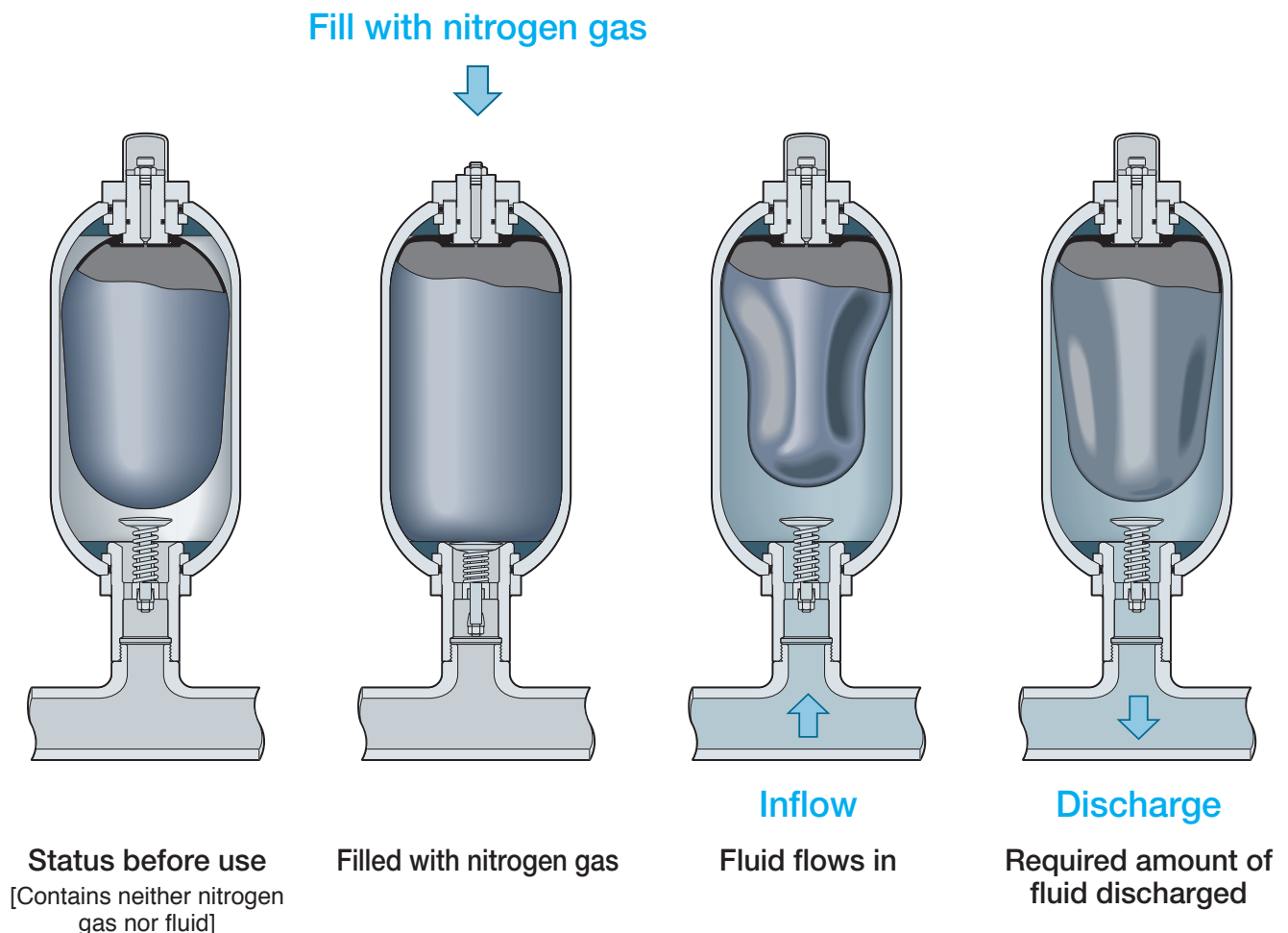

2. Structure (AT series)

TR Cap [Fusible-plug Safety Valve]

A safety valve that senses an abnormally high temperature. It can be attached to the gas valve as a replacement to the cap.

(*Can also be attached to a Minilator.)

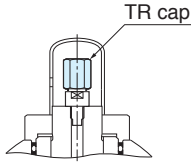

Gas Control Valve

The valve integrates a filling port for the nitrogen gas, a pressure gauge, and safety valve, and is attached to the valve stem.

(*Note that the valve stem differs from the gas valve.)

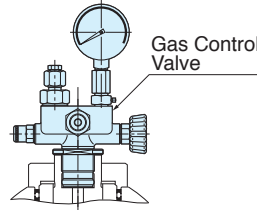

Gas Side Options

See: pages 37~39

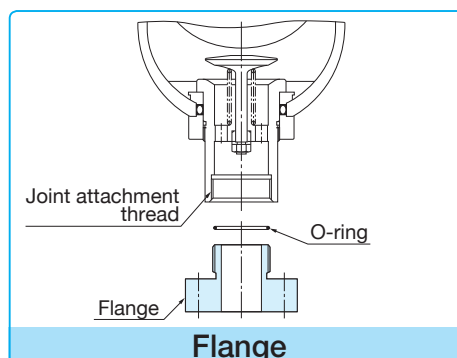
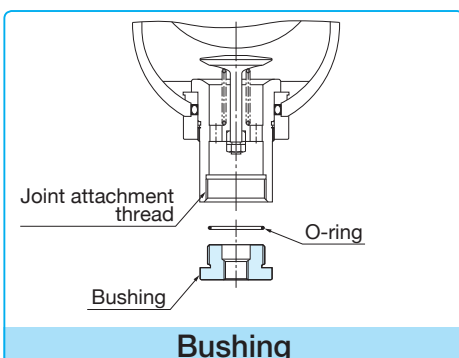
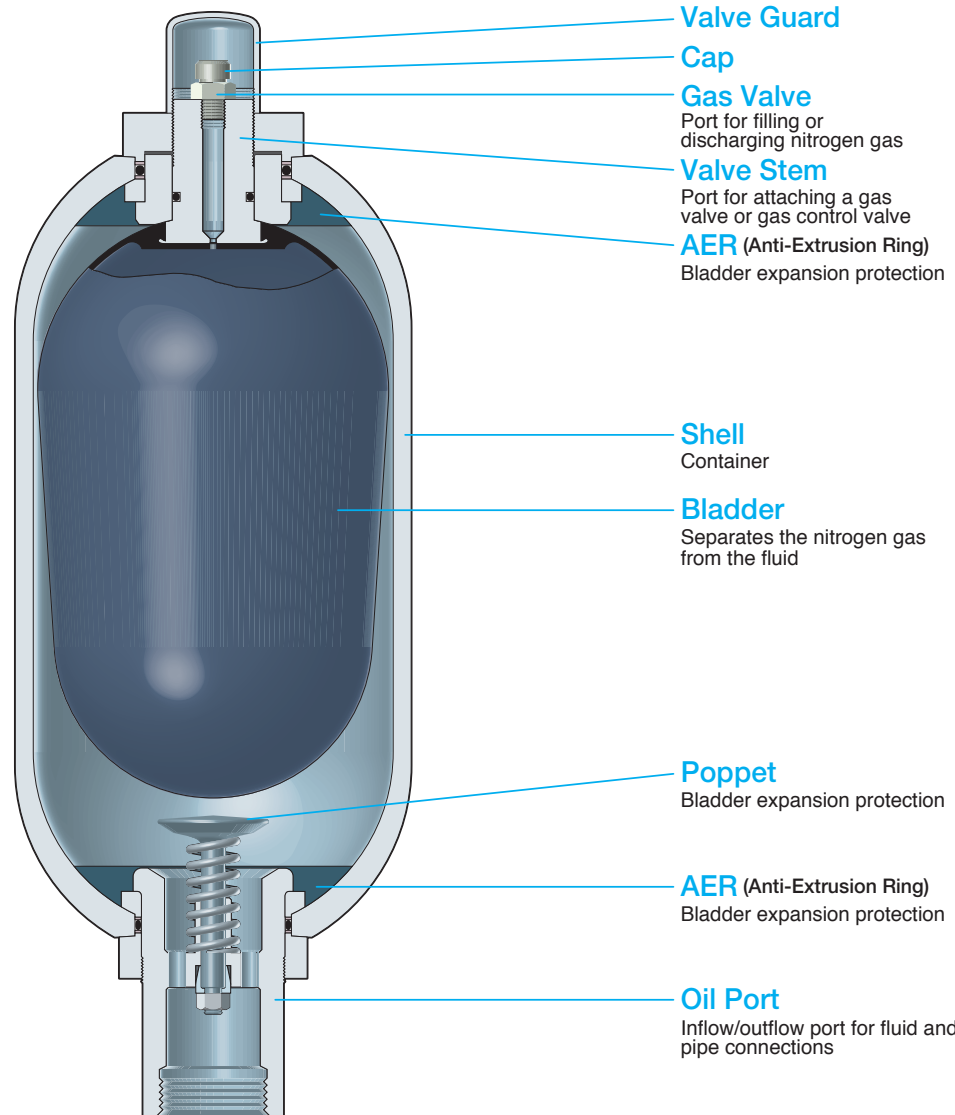

Joint for Fluid Port Connecting

Differing size bushings and flanges are available for use in connecting the accumulator to equipment and machinery.

See: pages 32~35

2. Use of Accumulator

1. Energy Accumulation

Accumulators are widely used as a supplementary energy source. The system in which pressurized oil discharged from accumulators is used to operate cylinders enables pumps to be smaller, shortens their cycles, and conserves energy.

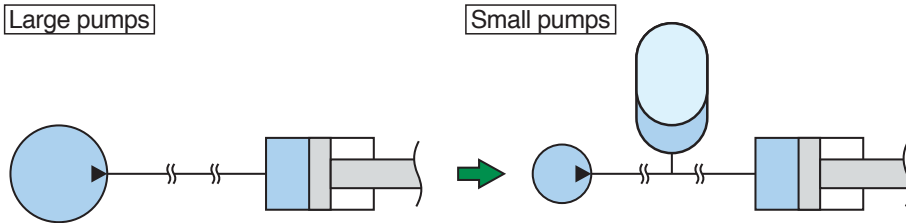

[Major Examples of Usage]

- Hydraulic presses
- Injection molding machines
- Die-cast machines
- Automotive brake systems
- Power shovels
- Vibration testing machines
- Circuit breakers for transformer substations
- Water supply systems
- Home pumps
- Equipment for ironworks, power plants, and chemical plants
- Ship engines

2. Pulse Absorption

All pressurized fluid discharged from pumps has a pulse. Pulses produce noise or vibrations that can cause instability or damage devices. The use of an accumulator can attenuate pulses.

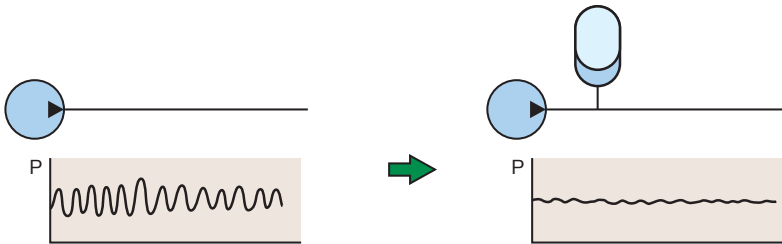

- Machine tools
- Breakers for construction machinery
- Concrete compressors
- Hydraulic elevators
- Power sprayers
- Water purification plants
- Descaling equipment

3. Impact Absorption

The rapid closure of valves or sudden changes in load within a hydraulic circuit can result in impact pressure in pipes, which can then lead to noise or damage to those pipes or devices. The use of an accumulator can mitigate any such internal shock.

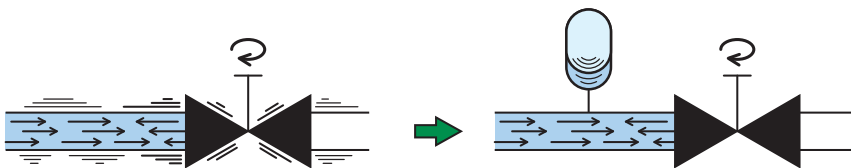

- Water pipes
- Jet fuel injection equipment
- Mud-water compressors
- Pipelines

4. Thermal Expansion Compensation

Changes in the volume of a liquid resulting from changes in the temperature within a closed circuit can increase or decrease the internal pressure. An accumulator can be used to mitigate any such fluctuations in the pressure.

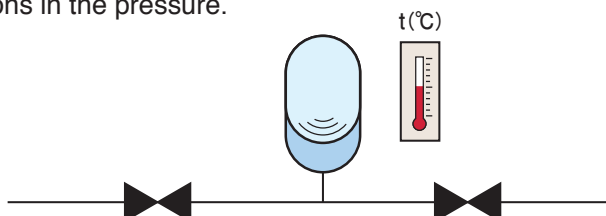

- Boilers
- Pressurized water heaters
- Central heating systems
- Fire extinguishing systems

5. Gas Spring

The use of the accumulators as a gas spring rather than a metal spring enables larger load systems to be downsized.

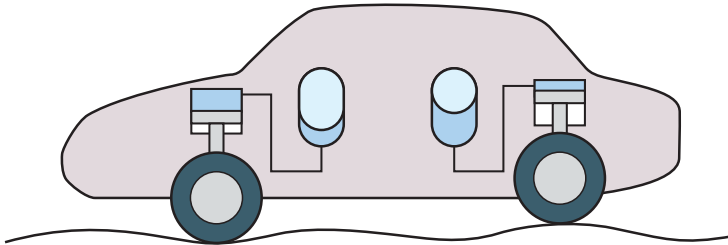

[Major Examples of Usage]

- Vehicle suspensions
- Suspensions for construction machinery or other vehicles
- Agricultural machinery
- Coal mills
- Cement mills
- Cone crushers

6. Equilibrium Action

The accumulators can be used as counter balances. The accumulators smoothly balance the weight or impact of products and machinery via gas pressure.

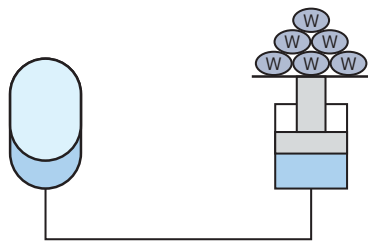

- Large crane systems
- Large-scale machinery tools
- Hydraulic pressure molding machinery

7. Leak Compensation

The accumulators can compensate for any decreases in pressure due to internal leaks and thus retain the pressure of pressure control circuits or during any maintenance work.

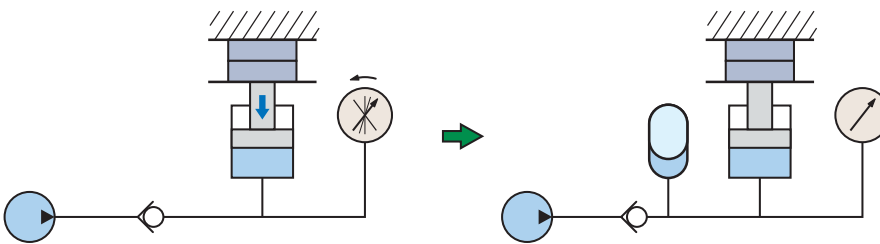

- Clamping equipment
- Other types of hydraulic equipment

8. Transfer Barrier

The use of a transfer barrier type accumulator enables transfers to take place within the fluid circuit without the different types of fluids or gases mixing.

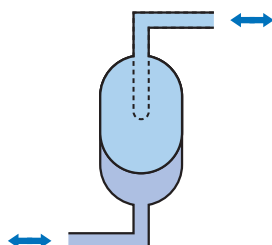

- Compressor lubricant supplier
- Boosters
- Sealed tanks

3. Type of Accumulator

NOK has a wide variety of accumulators available that can satisfy the demands of differing applications and usage conditions.

Minilators

Compact, small volume type

See: page 12

MA series

Stainless-steel type



ME series

Lightweight aluminum type



MB series

Steel type



MC series

Steel type



Diaphragm type

Maintenance-free, small volume spherical type

See: page 14

MU series

Rubber diaphragm type



See: page 15

MUV series

Rubber/resin layered diaphragm type



Gas retention to at least 10 times that of single rubber type

Bladder type

Replaceable bladders for subsequent use with larger products

See: page 18

AL series



Bladder replaceable from the fluid side

See: page 20

AT series



Bladders may be replaced either from the gas or fluid side

Piston type

Enables higher pressure and larger volume designs

See: page 30

PA series



(NB) No further surface treatment beyond a basecoat applied to standard products.

Expansion tank

Low-pressure type for use with water that is compliant with the Food Sanitation Law of Japan

See: page 31

ET series



Type A



Type B



Type C

4. Selection Procedure of Accumulator

Use the following procedure to select the most appropriate accumulator:

1. Determine the application of the accumulator page 4

Determine the application of the accumulator from its intended use.

Examples of Intended Use:	Use:
● Reducing the power supplied to a hydraulic press	Energy Accumulation
● Instantaneous operation of a hydraulic cylinder	Energy Accumulation
● Preventing pump pulsations from damaging devices	Pulse Absorption
● Preventing any damage to pipes when switching valves	Impact Absorption
● Preventing any damage to devices when a closed circuit is at high temperature	Thermal Expansion Compensation
● Car and crane suspension systems	Gas Spring
● Small power operation of heavy objects	Equilibrium Action
● Preventing any loss in pressure due to leakage from valves while pumps are under suspension	Leak Compensation
● Compressing high-viscosity lubrication using hydraulic oil	Transfer Barrier

2. Calculate the required volume of gas page 58

Calculate the required volume of gas from the intended usage conditions.

Example calculations and worksheets are available for use in calculating the relevant energy accumulation, pulsation absorption, and impact absorption.

Please consult your nearest sales contact for any other purposes.

3. Select the most appropriate accumulator pages 9 to 39

After calculating the required volume of gas, set the following specifications to select the most appropriate accumulator.

Specification Setting	
① Maximum Working Pressure	System pressure or greater
② Volume of Gas	Calculated required volume of gas or greater
③ Rubber Material	Must comply with the fluid used and temperature conditions
④ Maximum Discharge Rate	Necessary rate or greater
⑤ Specification of Wet Part	Must comply with the fluid used
⑥ Joint for Fluid Port Connecting	Kind and size
⑦ Specifications Required by the Gas Side	Kind and size

Please consult your nearest sales contact in advance in any case where you will require certification or application to follow any pertinent laws or standards.

- High Pressure Gas Safety Law (high pressure gas production equipment)
- Industrial Safety and Health Law (class-2 pressure vessel)
- ASME U Stamp (American Society of Mechanical Engineers)
- Regulation for Boiler and Pressure Vessel Manufacture Licensing (China)
- CE Marking (European Pressure Equipment Directive)
- Other

The Product Codes for the AT series vary by applicable laws and standards.
See pages 22 through 28.

Fill in the Accumulator Selection Request (page 68) and we will select the most appropriate accumulator for you.

5. Accumulator Lists of Maximum Working Pressures and Volumes

Accumulator for Use in Japan

Series	Nominal Volume	Maximum Working Pressure: MPa							
		6.86	14.7	16	20.6	22.6	29.4	34.3	
MA MB MC ME MU MUV	30cm ³	ME70-30							
	100	ME70-100			MB210-100				
	150	MUV70-150							
	300	MA70-300				MB210-300			
		ME70-300							
		MU70-300							
	500	MA70-500				MB210-500			
		ME70-500							
		MUV70-500							
		MU70-500							
	700		MU150-700						
	1000	MC70-1000				MC210-1000			
	2000	MC70-2000				MC210-2000			
3000	MC70-3000				MC210-3000				
5000	MC70-5000				MC210-5000				
AL AT PA	1 ℓ		AL150-1		PA210-1		AL300-1		
	2				PA210-2				
	2.4		AL150-2.4				AL300-2.4		
	3				PA210-3				
	4		AL150-4		PA210-4		AL300-4		
	5		AL150-5		PA210-5		AL300-5		
	10			AT18M-10	PA210-10	AT25M-10		AT35M-10	
	20			AT18M-20	PA210-20	AT25M-20		AT35M-20	
	30			AT18M-30	AT23M-30	AT25M-30		AT35M-30	
					PA210-30				
	40				AT23M-40				
					PA210-40				
	50			AT18M-50	AT23M-50	AT25M-50			
					PA210-50				
	60				AT23M-60				
80				AT23M-80					
120				AT23M-120					
150				AT23M-150					
160				AT23M-160					





Expansion Tank for Use in Japan

Series	Nominal Volume	Maximum Working Pressure: MPa			
		0.45	0.5	0.85	2.0
ET	0.5 ℓ	ET4.5-0.5			
	1	ET4.5-1			
	2		ET5-2		
	10			ET8.5-10	
	20			ET8.5-20	ET20-20

AT Series for Overseas Use

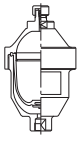
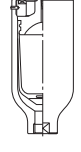
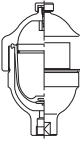
Series	Nominal Volume	Maximum Working Pressure: MPa			
		18	23	25	35
AT	10 ℓ	AT18M-10		AT25M-10	AT35M-10
	20	AT18M-20		AT25M-20	AT35M-20
	30	AT18M-30	AT23M-30	AT25M-30	AT35M-30
	40		AT23M-40		
	50	AT18M-50	AT23M-50	AT25M-50	
	60		AT23M-60		
	80		AT23M-80		
	120		AT23M-120		
	150		AT23M-150		
	160		AT23M-160		

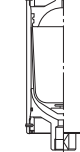



6. NOK Accumulator Series Lists

Volume Category		Less than 1 ℓ						1 ~ 5 ℓ			
Type of Accumulator		Minilators			Diaphragm type			Minilators	Bladder type		Piston type
Series	Model	MA	MB	ME	MU	MUV	MC	AL	PA		
	Shape										
	Shell Material	Stainless Steel	Steel	Aluminum	Steel	Steel	Steel	Steel	Steel	Steel	
Standard Surface Treatment	Stainless Steel Base	Parkerized	Aluminum Base	Plated	Plated	Parkerized	Parkerized	Basecoat			
Basic Specifications	(Unit)	(cm ³)			(cm ³)			(cm ³)	(ℓ)	(ℓ)	
	Nominal Volume	300·500	100·300·500	30 100 300 500	300 500 700	150 500	1000·2000 3000·5000	1·2.4 4·5	1·2·3·4·5		
Maximum Working Pressure (MPa)		6.86	20.6	6.86	6.86 14.7	6.86	6.86·20.6	14.7·29.4	20.6		
Maximum Discharge Flow (ℓ/min) ^{*1}		30	30 80	20 30	30	10 30	80	126 370	700~1400		
Applicable Fluids ^{*2}	General Mineral Oil	○	○	○	○	○	○	○	○		
	Phosphate Ester	○	○	○	—	—	○	○	○		
	Industrial Water	○	(○)	○	—	—	(○)	○	(○)		
	Water Glycol	○	○	○	—	—	○	○	○		
	Potable Water	—	—	—	—	—	—	—	—		
Applicable Temperature Range for Each Type of Rubber Material ^{*3}	(°C)	100 0 -20			100 0 -20			100 0 -20		100 0 -20	
		80 -40			100 -20			80 -40		150 -15	
Maximum Compression Ratio ^{*5}		4			8	4	3	4	Restrictionless		
Specifications of Joint for Fluid Port Connecting		Rc3/8	Rc3/8 Rc1/2	Rc3/8	R1/2 G1/2	R3/4 G3/4	R3/8 G3/8	R3/4 G3/4	Rc3/4	Select Bushing or Flange	
Specifications required by the gas side	TR Caps Included ^{*5}	○			—			○	○	○	
	Gas Control Valve Included	—			—			—	○	○	
Direction Attached		Vertical/Horizontal			Restrictionless			Vertical	Vertical	Restrictionless	
Maintenance	Gas Filling	Supported			Not Supported			Supported	Supported	Supported	
	Bladder and Seal Replacement	Consult your nearest sales contact	Not Supported			Not Supported	Not Supported (Gas retention at least 10 times that of MU)	Not Supported	Supported Replace from the fluid side	Consult your nearest sales contact	
Refer to the Model Code Dimensions and Product Code Page		Page 12			Page 14	Page 15	Page 12	Page 18	Page 30		

*1: General mineral oil used at room temperature.

*2: The specifications of the accumulators can vary depending on the type of fluid used. For more details please refer to the Model Code Configurations of each individual series.

*3: The pressure of the nitrogen gas in the accumulator can gradually drop as a result of it seeping through the rubber. Caution should be exercised with regard to maintenance as the pressure of the gas can drop faster at higher temperatures (see page 55).

-  **NBR** (Standard Nitrile Rubber)
-  **NBR** (Nitrile Rubber for Low Temperature Use)
-  **IIR** (Butyl Rubber)
-  **FKM** (Fluororubber)
-  **CM** (Chlorinated Polyethylene)

Consult your nearest sales contact if you wish to constantly use the product at high temperature.

[Meaning of symbols used]

- ◎ : Standard product (with Model Codes and Product Codes provided)
- : No Product Code provided. Specify using Model Code.
- (○) : Consult your nearest sales contact.

10~160 ℓ		0.5~20 ℓ			Volume Category	
Bladder type		Expansion tank			Type of Accumulator	
AT		ET			Model	
Piston type		Type A Type B Type C			Shape	Series
PA		Steel				
Steel		Paint			Standard Surface Treatment	
Parkerized		(ℓ)			(Unit)	
(ℓ)		Type A	Type B	Type C	Nominal Volume	
10·20·30·40·50·60 80·120·150·160		0.5·1	2	10·20	20	Basic Specifications
16~35*6		0.45	0.5	0.85	2.0	
20.6		30			90	90
600~4800*6		1400~2800			Maximum Discharge Flow (ℓ/min)*1	
◎		(○) <td colspan="2">General Mineral Oil</td>			General Mineral Oil	
○		—			Phosphate Ester	
○		○ <td colspan="2">Industrial Water</td>			Industrial Water	
○		—			Water Glycol	
—		◎ <td colspan="2">Potable Water</td>			Potable Water	
100		85 <td colspan="2" rowspan="2">Applicable Temperature Range for Each Type of Rubber Material *3</td>			Applicable Temperature Range for Each Type of Rubber Material *3	
80		85				
100		—10			100	
—20		—10			0	
—40		2			Maximum Compression Ratio*5	
—30		G1/2	G3/4	R3/4	Rc1 1/4	Specifications of Joint for Fluid Port Connecting
—40		Restrictionless			TR Caps Included*5	
—15		Restrictionless			Gas Control Valve Included	
—40		Restrictionless			Specifications required by the gas side	
4		Vertical/Horizontal			Direction Attached	
Restrictionless		Not Supported			Supported	
Select Bushing or Flange		Not Supported			Supported	
◎		Not Supported			Gas Filling	
○		Not Supported			Bladder and Seal Replacement	
Vertical		Not Supported			Maintenance	
Restrictionless		Not Supported			Refer to the Model Code Dimensions and Product Code Page	
Supported		Not Supported			Page 31	
Supported		Not Supported			Page 20	
Replaceable either from the gas or fluid side		Not Supported			Page 30	
Consult your nearest sales contact		Not Supported			Page 30	

*4: Compression Ratio: Ratio of maximum operating pressure (P₃) to gas filling pressure (P₁). [P₃/P₁]
 Convert the value to the absolute pressure for use in the calculation if the accumulator is used at 1 MPa or less.
 [Absolute Pressure (MPa) = Gauge Pressure + 0.1013]

Note that use of the product at a pressure exceeding the maximum compression ratio can shorten the useful lifespan of the bladder.

*5: Not applicable if the ambient temperature always exceeds 80 °C.

*6: The maximum working pressure and maximum discharge flow for the AT series can vary by individual model. See [AT Series] on pages 20 and 21 for more details.

7. Minilator

MA, MB, MC, ME series

Compact and Small-Volume Bladder Type Accumulator

Model Code Configuration

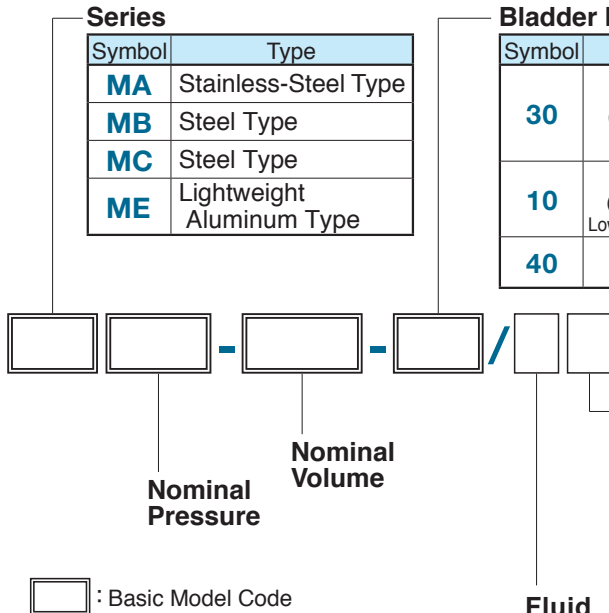

(Note) Because this material cannot be applied in some kinds of phosphoric ester hydraulic oil, please consult your nearest sales.

Specifications Required by the Gas Side

Symbol	Specification	Page
None	—	—
E	TR Cap	37 Page (Note)

(Note) In case of ambient temperature always exceeding 80°C, TR Cap cannot be used.

Fluid

●MB·MC series

Symbol	Fluid	Note
None	Common Mineral Hydraulic Oil Phosphoric Ester Hydraulic Oil	—
W	Industrial Water (Components ①, ②, and ③ are made of SUS304)	The shape and dimensions can differ from those of standard products.

●MA·ME series

Symbol	Fluid
None	Common Mineral Hydraulic Oil Phosphoric Ester Hydraulic Oil Industrial Water

MA series
(Stainless-Steel Type)
[SUS316]

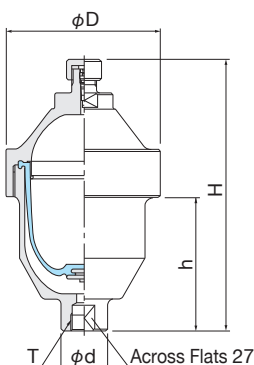

MB series
(Steel Type)

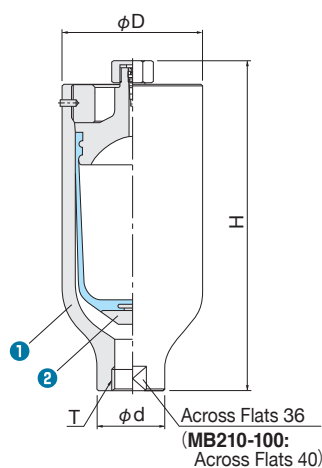

MC series
(Steel Type)

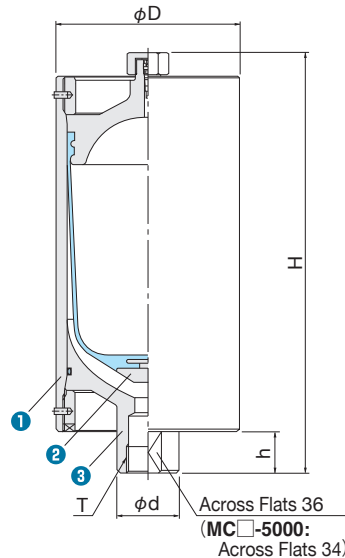

ME series
(Lightweight Aluminum Type)

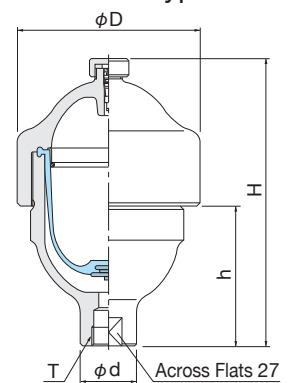

Minilator Standard Product Model Codes and Dimensions

Includes TR Cap

MA, ME series

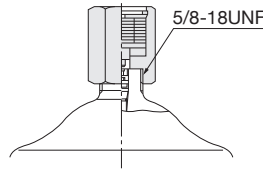

MB, MC series

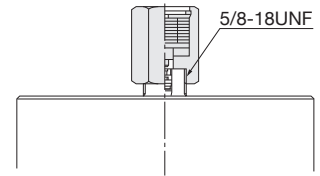

- Rubber Material: Symbol 30 (NBR Standard Nitrile Rubber)
- Applicable Fluid: Common Mineral Hydraulic Oil

Symbol	Model Code	Maximum Working Pressure MPa	Gas Volume cm ³	Mass kg	Dimension mm				Thread T	Maximum Discharge Flow Rate ℓ/min	Product Code				
					H	D	h	d			Without TR Cap	With TR Cap			
MA	MA 70- 300-30(/E)	6.86	310	1.8	169(187)	96	83	30	Rc3/8	30	KA1789 A0	KA6237 A4			
	MA 70- 500-30(/E)		480	2.0	215(233)		129				KA4414 A4	KA6540 A4			
MB	MB210- 100-30(/E)	20.6	100	1.0	166(183)	87	—	48	Rc3/8	30	KA4887 B4	KA6601 B4			
	MB210- 300-30(/E)		300	4.5	205(224)		—				40	Rc1/2	80	KA1598 B0	KA3180 B4
	MB210- 500-30(/E)		500	5.5	265(285)		—				40			KA1599 B0	KA4284 B0
MC	MC 70-1000-30(/E)	6.86	980	7.4	260(280)	114.3	25	40	Rc3/4	80	KA0062 C0	KA4224 C0			
	MC 70-2000-30(/E)		2000	11.0	420(440)						—	—	KA4499 C4	KA6708 C4	
	MC 70-3000-30(/E)		2600	12.0	493(513)						—	—	KA0063 C0	KA4319 C0	
	MC 70-5000-30(/E)		4800	18.0	490(510)						152.4	—	KA0064 C0	KA4194 C0	
	MC210-1000-30(/E)	20.6	980	8.6	270(290)	114.3	25	40	Rc3/4		KA0058 C0	KA4023 C0			
	MC210-2000-30(/E)		2000	12.0	430(450)						—	—	KA4500 C4	KA5769 C4	
	MC210-3000-30(/E)		2600	13.0	510(531)						—	—	KA0060 C0	KA4235 C0	
	MC210-5000-30(/E)		5100	29.0	490(510)						165.2	20	KA0061 C0	KA4717 C0	
ME	ME 70- 30-30(/E)	6.86	30	0.25	93(113)	103	62	37	30	Rc3/8	20	KA2475 E0	KA4954 E0		
	ME 70- 100-30(/E)		110	0.5	110(130)		86					45	KA2476 E0	KA4214 E0	
	ME 70- 300-30(/E)		310	1.0	163(182)		79					31	30	KA2477 E0	KA4017 E0
	ME 70- 500-30(/E)		480	1.1	210(230)		126							KA3306 E0	KA4280 E0

Notes: () with TR Cap
Please designate Model Code and Product Code in your order.

Fixing Band for MC Series

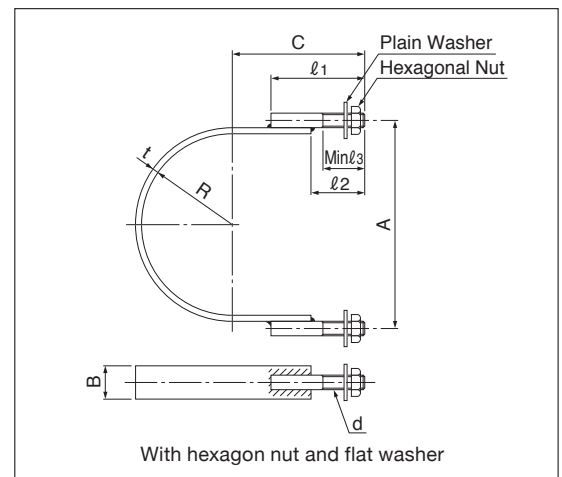

Model Code	Applicable MC Series	Dimension mm										Mass kg	Product Code
		A	B	C	l ₁	l ₂	l ₃	d	R	t			
PAL101-101	MC 70·210 -1000, 2000, 3000	135	22	85	60	35	27	M10	58	4.5	0.3	EB6611 Z4	
PAL101-103	MC 70·210 -5000	187	22	115	80	40	31	M10	84	4.5	0.4	EB6613 Z4	

Please designate Model Code and Product Code in your order.

8. Diaphragm Type Accumulator

MU series

Spherical Accumulator with Rubber Diaphragm

Model Code Configuration

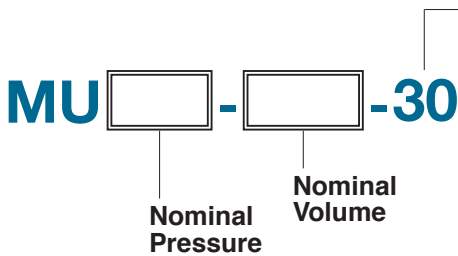

Rubber Material

Symbol	Material	Fluid	Temperature
30	NBR (Standard Nitrile Rubber)	Common Mineral Hydraulic Oil	-20~100°C

- The product is delivered filled with nitrogen gas at the factory. Please ensure to let us know the desired gas pressure (___ MPa at ___ °C) when placing an order.
- Cannot be refilled with gas. Use at 50 °C or less recommended.

The pressure will drop faster (natural loss of gas due to permeation) at higher working temperatures, which also results in faster degradation of the functionality of the accumulator.

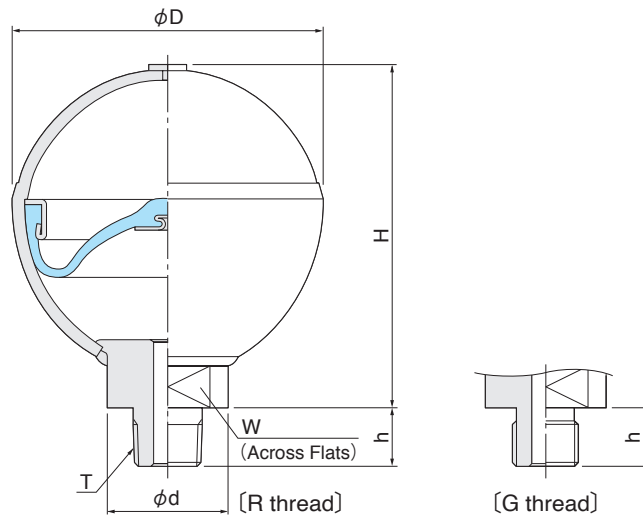

Model Code	Maximum Working Pressure MPa	Gas Volume cm ³	Mass kg	Dimension mm					Thread T	Maximum Discharge Flow Rate ℓ/min	Product Code
				H	D	d	W	h			
MU 70-300-30	6.86	300	1.2	107	98	38	27	18	R1/2	30	KA6917 U4
				109				G1/2	KA6909 U4		
MU 70-500-30	6.86	500	1.7	122	111	38	27	18	R1/2	30	KA6918 U4
				122				G1/2	KA6910 U4		
MU150-700-30	14.7	700	3.0	142	130	56	36	21	R3/4	30	KA6919 U4
				146				G3/4	KA6911 U4		

Please designate Model Code and Product Code in your order.

[Reference] Dimensions of the G thread used to attach other equipment (O-ring seal: JIS B 2351)

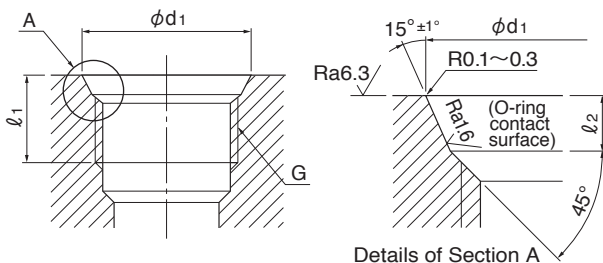

Nominal Designation	Dimension mm			Included O-ring
	$d_1^{+0.1}_0$	l_1	$l_2^{+0.4}_0$	
G1/2	22.6	19	2.5	1B P18
G3/4	29.8	20	3.5	1B P22.4

MUV series

Spherical Accumulator with Rubber/Resin Layered Diaphragm
Long-life type retaining at least 10 times as much gas as the MU type

Model Code Configuration

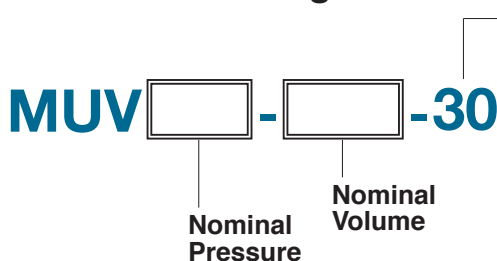

Rubber Material

Symbol	Material	Fluid	Temperature
30	NBR (Standard Nitrile Rubber)	Common Mineral Hydraulic Oil	-20~100°C

- The product is delivered filled with nitrogen gas at the factory. Please ensure to let us know the desired gas pressure (___ MPa at ___ °C) when placing an order.
- Cannot be refilled with gas. Use at 80 °C or less recommended.

Use of NOK's polymeric material technology and processing technology has resulted in a resin layered diaphragm that dramatically improves the gas retention of accumulators. This accumulator should be selected if a longer lifespan and maintenance-free operation are desired.

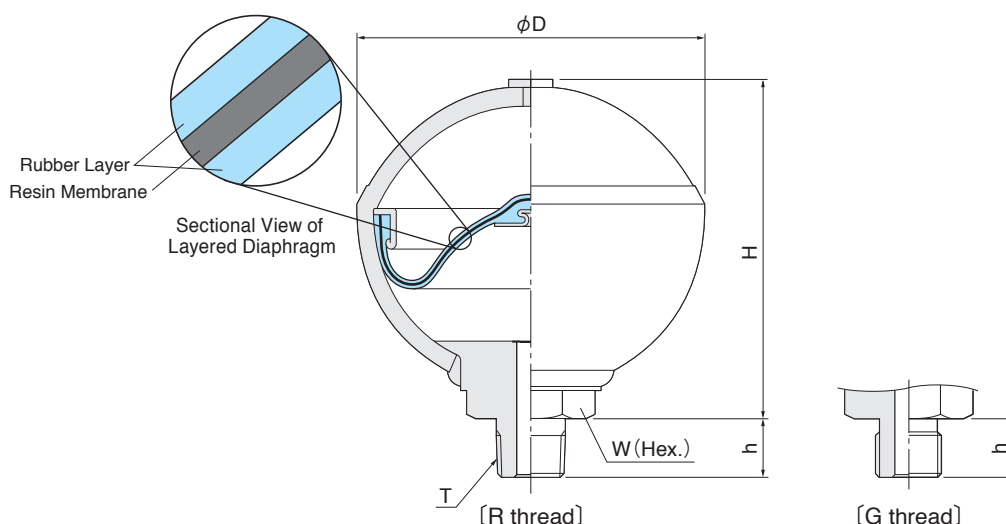

Model Code	Maximum Working Pressure MPa	Gas Volume cm ³	Mass kg	Dimension mm				Thread T	Maximum Discharge Flow Rate ℓ/min	Product Code
				H	D	W	h			
MUV70-150-30	6.86	150	0.7	93	86	30	14	R3/8	10	KA6912 U4
G3/8								KA6949 U4		
MUV70-500-30	6.86	500	2.5	117	128	36	18	R3/4	30	KA6914 U4
G3/4								KA6951 U4		

Please designate Model Code and Product Code in your order.

[Reference] Dimensions of the G thread used to attach other equipment (O-ring seal: JIS B 2351)

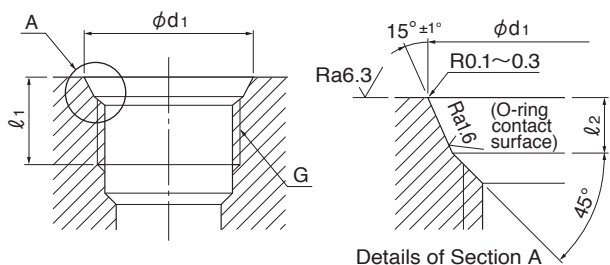

Nominal Designation	Dimension mm			Included O-ring
	$d_1^{+0.1}_0$	ℓ_1	$\ell_2^{+0.4}_0$	
G3/8	18.6	16	2.5	1B P14
G3/4	29.8	20	3.5	1B P22.4

9. Bladder Type Accumulator

Model Code Configuration

① Series

Symbol
AL
AT

② Nominal Pressure

③ Nominal Volume

□ : Basic Model Code

⑦ Gas Control Valve Types

Symbol	Specification	Page
None	Standard Type	—
GC	With Gas Control Valve Types	Page 38

④ Rubber Material

Symbol	Material	Fluid	Temperature	Note
30	NBR (Standard Nitrile Rubber)	Common Mineral Hydraulic Oil, Industrial Water, Water Glycol	-20~100°C	Standard Material
10	NBR (Nitrile Rubber for Low Temperature Use)	Common Mineral Hydraulic Oil	-40~80°C	Material For Low Temperature
40	IIR (Butyl Rubber)	Phosphoric Ester Hydraulic Oil	-30~100°C	(Note)

(Note) Because this material cannot be applied in some kinds of phosphoric ester hydraulic oil, please consult your nearest sales contact.

⑥ Specifications Required by the Gas Side

Symbol	Specification	Page
None	—	—
E	TR Cap	Page 37 (Note)
M	Fuse Metal Safety Valve	Page 39
GF06	Gas Port Flange used as Transfer Barrier	Page 29

(Note) In case of ambient temperature always exceeding 80°C, TR Cap cannot be used.

⑤ Joint for Fluid Port Connecting

Symbol	Specification	Page
None	No Connecting Part	—
T**	Bushing	Page 32
F**	21 MPa Flange Set	Page 33
H**	35 MPa Flange Set	Page 34
D**	Manifold Direct Assembly Type	Page 35

Standard Material: Steel
For Industrial Water: Stainless Steel

⑧ Fluid

Symbol	Fluid	Fluid Contact Metal Parts Specification (See the left picture.)		
		Inner Surface of Shell	Retainer Ring (For AER)	Oil Port Body Assembly
None	Common Mineral Hydraulic Oil Phosphoric Ester Hydraulic Oil	Parkerizing (Standard)		
W	Industrial Water	Epoxy Coating (Note)	Stainless Steel	

(Note) The maximum working temperature of the epoxy coated type is 40 °C.

⑨ Type of Oil Port Body Assembly

Symbol	Maximum Discharge Flow Rate (ℓ /min)			
	AL1, 2.4 ℓ	AL4, 5 ℓ	AT10~60 ℓ	AT80~160 ℓ
None	126	370	600	1800
SH	—	—	1260	—
HF	—	—	1800	—
MH	—	—	2280	
UH	—	—	4800	

[Fluid Contact Metal Parts]

Inner Surface of Shell

Retainer Ring (For AER)

Oil Port Body Assembly

*The Product Codes for the AT series vary by applicable laws and standards.
See pages 22 through 28.

■ Example of Model Code Configuration

Model Code	Specification
AT 25M-10-30 ① ② ③ ④	① AT Series ② Maximum Working Pressure: 22.6 MPa (Japanese Model Specifications) ③ Nominal Volume: 10 ℓ ④ Rubber Material : NBR (Standard Nitrile Rubber)
AT 25M-10-30/T06 ① ② ③ ④ ⑤	① AT Series ② Maximum Working Pressure: 22.6 MPa (Japanese Model Specifications) ③ Nominal Volume: 10 ℓ ④ Rubber Material : NBR (Standard Nitrile Rubber) ⑤ Joint: Bushing Rc3/4
AT 25M-10-30/T06 E ① ② ③ ④ ⑤ ⑥	① AT Series ② Maximum Working Pressure: 22.6 MPa (Japanese Model Specifications) ③ Nominal Volume: 10 ℓ ④ Rubber Material : NBR (Standard Nitrile Rubber) ⑤ Joint: Bushing Rc3/4 ⑥ With TR Cap
AT 25M-10 GC-30/F06 ① ② ③ ⑦ ④ ⑤	① AT Series ② Maximum Working Pressure: 22.6 MPa (Japanese Model Specifications) ③ Nominal Volume: 10 ℓ ④ Rubber Material : NBR (Standard Nitrile Rubber) ⑤ Joint: F Type Flange: 25A ⑦ With Gas Control Valve Types Spring Safety Valve as the Code Is Not Followed by an M (See page 38 for the Model Code Configuration of GC models.)
AT 25M-10 GC-30/W T06 M ① ② ③ ⑦ ④ ⑧ ⑤ ⑥	① AT Series ② Maximum Working Pressure: 22.6 MPa (Japanese Model Specifications) ③ Nominal Volume: 10 ℓ ④ Rubber Material : NBR (Standard Nitrile Rubber) ⑤ Joint: Bushing Rc3/4 ⑥ Fuse Metal Safety Valve when Combined with GC (M) ⑦ With GC ⑧ For Water Service (Inner Surface of Shell: Epoxy Coating, Fluid Contact Metal Parts: Stainless Steel)
AT 25M-10 GC-30-HF/WF16 M ① ② ③ ⑦ ④ ⑨ ⑧ ⑤ ⑥	① AT Series ② Maximum Working Pressure: 22.6 MPa (Japanese Model Specifications) ③ Nominal Volume: 10 ℓ ④ Rubber Material : NBR (Standard Nitrile Rubber) ⑤ Joint: F Type Flange 50A ⑥ Fuse Metal Safety Valve when Combined with GC ⑦ With GC ⑧ For Water Service ⑨ High Flow, Maximum Discharge Flow Rate 1800 ℓ/min

AL series (1, 2.4, 4, 5 ℓ)

Bladder Type Accumulator with the Bladder Replaceable from the Fluid Side

Basic Model

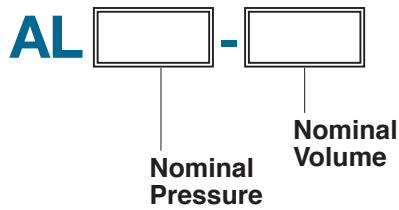

With TR CAP

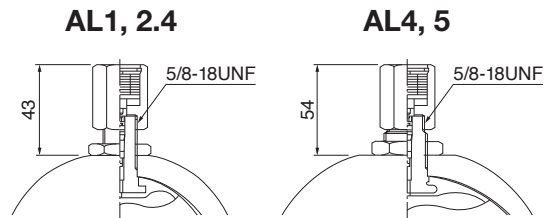

AL□-1, 2.4

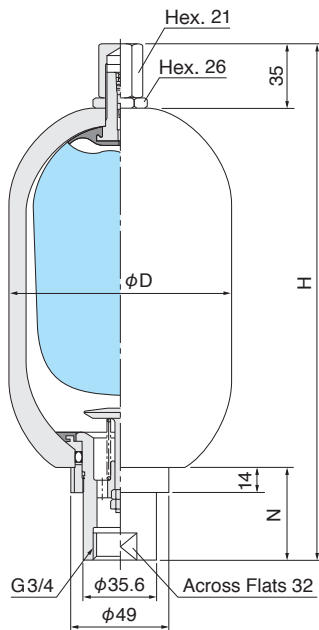

AL□-4, 5

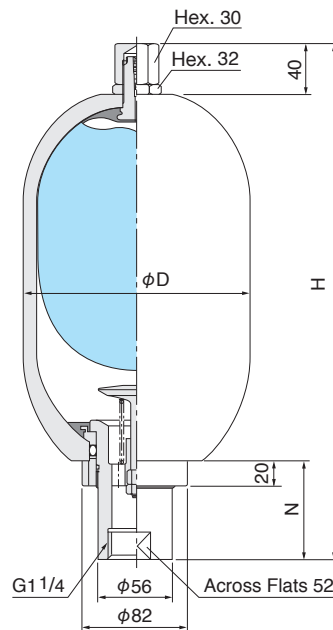

Nominal Volume ℓ	Basic Model	Maximum Working Pressure MPa	Gas Volume ℓ	Mass kg	Dimension mm			Maximum Discharge Flow Rate ℓ/min
					H ^(Note)	D	N	
1	AL150-1	14.7	1.0	7.6	282(290)	120.0	51	126
	AL300-1	29.4						
2.4	AL150-2.4	14.7	2.5	13.6	487(495)	120.0	51	
	AL300-2.4	29.4						
4	AL150-4	14.7	3.7	14.3	404(418)	168.3	79	370
	AL300-4	29.4		20.3	405(419)	177.8	78	
5	AL150-5	14.7	5.2	18.3	495(509)	168.3	79	
	AL300-5	29.4		26.3	496(510)	177.8	78	

Note: Values in brackets represent the dimensions with a TR cap attached.

AL series Standard Model

- Rubber Material: Symbol 30 (NBR Standard Nitrile Rubber)
- Applicable Fluid: Common Mineral Hydraulic Oil

Nominal Volume ℓ	Maximum Working Pressure MPa	Joint for Fluid Port Connecting	Size	Without TR CAP		With TR CAP		
				Model Code	Product Code	Model Code	Product Code	
1	14.7	None	G3/4	AL150-1-30	KY5001 B5	AL150-1-30/E	KY7025 B5	
		Bushing	R3/8	/T03	KY5002 A5	/T03E	KY7002 B5	
			R1/2	/T04	KY5003 B5	/T04E	KY7003 B5	
			R3/4	/T06	KY5004 B5	/T06E	KY7004 B5	
		F Type Flange	15A	/F04	KY5533 B5	/F04E	KY7533 B5	
			20A	/F06	KY5534 B5	/F06E	KY7534 B5	
	29.4	None	G3/4	AL300-1-30	KY5005 B5	AL300-1-30/E	KY7005 B5	
		Bushing	R3/8	/T03	KY5006 A5	/T03E	KY7006 B5	
			R1/2	/T04	KY5007 B5	/T04E	KY7007 B5	
			R3/4	/T06	KY5008 B5	/T06E	KY7008 B5	
		H Type Flange	15A	/H04	KY5841 B5	/H04E	KY7841 B5	
			20A	/H06	KY5842 B5	/H06E	KY7842 B5	
	2.4	14.7	None	G3/4	AL150-2.4-30	KY5009 B5	AL150-2.4-30/E	KY7009 B5
			Bushing	R3/8	/T03	KY5010 A5	/T03E	KY7010 B5
R1/2				/T04	KY5011 B5	/T04E	KY7011 B5	
R3/4				/T06	KY5012 B5	/T06E	KY7012 B5	
F Type Flange			15A	/F04	KY5537 B5	/F04E	KY7537 B5	
			20A	/F06	KY5538 B5	/F06E	KY7538 B5	
29.4		None	G3/4	AL300-2.4-30	KY5013 B5	AL300-2.4-30/E	KY7013 B5	
		Bushing	R3/8	/T03	KY5014 A5	/T03E	KY7014 B5	
			R1/2	/T04	KY5015 B5	/T04E	KY7015 B5	
			R3/4	/T06	KY5016 B5	/T06E	KY7016 B5	
		H Type Flange	15A	/H04	KY5843 B5	/H04E	KY7843 B5	
			20A	/H06	KY5844 B5	/H06E	KY7844 B5	
4		14.7	None	G11/4	AL150-4-30	KY5017 B5	AL150-4-30/E	KY7017 B5
			Bushing	R1/2	/T04	KY5018 B5	/T04E	KY7018 B5
	R3/4			/T06	KY5019 A5	/T06E	KY7019 B5	
	20A			/F06	KY5541 B5	/F06E	KY7541 B5	
	F Type Flange		25A	/F08	KY5542 B5	/F08E	KY7542 B5	
			None	G11/4	AL300-4-30	KY5021 B5	AL300-4-30/E	KY7021 B5
	29.4	Bushing	R1/2	/T04	KY5022 B5	/T04E	KY7022 B5	
			R3/4	/T06	KY5023 A5	/T06E	KY7023 B5	
		H Type Flange	20A	/H06	KY5845 B5	/H06E	KY7845 B5	
			25A	/H08	KY5846 B5	/H08E	KY7846 B5	
	5	14.7	None	G11/4	AL150-5-30	KY5001 B6	AL150-5-30/E	KY7001 B6
			Bushing	R1/2	/T04	KY5002 B6	/T04E	KY7002 B6
				R3/4	/T06	KY5003 A6	/T06E	KY7003 B6
				20A	/F06	KY5178 B6	/F06E	KY7178 B6
F Type Flange			25A	/F08	KY5179 B6	/F08E	KY7179 B6	
			None	G11/4	AL300-5-30	KY5005 B6	AL300-5-30/E	KY7005 B6
29.4		Bushing	R1/2	/T04	KY5006 B6	/T04E	KY7006 B6	
			R3/4	/T06	KY5007 A6	/T06E	KY7007 B6	
		H Type Flange	20A	/H06	KY5340 B6	/H06E	KY7340 B6	
			25A	/H08	KY5341 B6	/H08E	KY7341 B6	

Please designate Model Code and Product Code in your order.

AT series

(10, 20, 30, 40, 50, 60, 80, 120, 150, 160 ℓ)

Bladder Type Accumulator with the Bladder Replaceable from Both the Gas and Fluid Sides

Applicable Regulations and Standards

Japan	High Pressure Gas Safety Law
China	Regulation for Boiler and Pressure Vessel Manufacture Licensing
EU	Pressure Equipment Directive(P.E.D.) (CE Mark)
USA	ASME Sec. VIII Div. 1 (U-Stamp)

Please contact us concerning compliance with any other regulations and standards.

10~60 ℓ

10~50 ℓ

80~160 ℓ

10~160 ℓ

- Standard Model
- SH Type

- HF, MH Type

- Standard Model
- MH Type

- UH Type

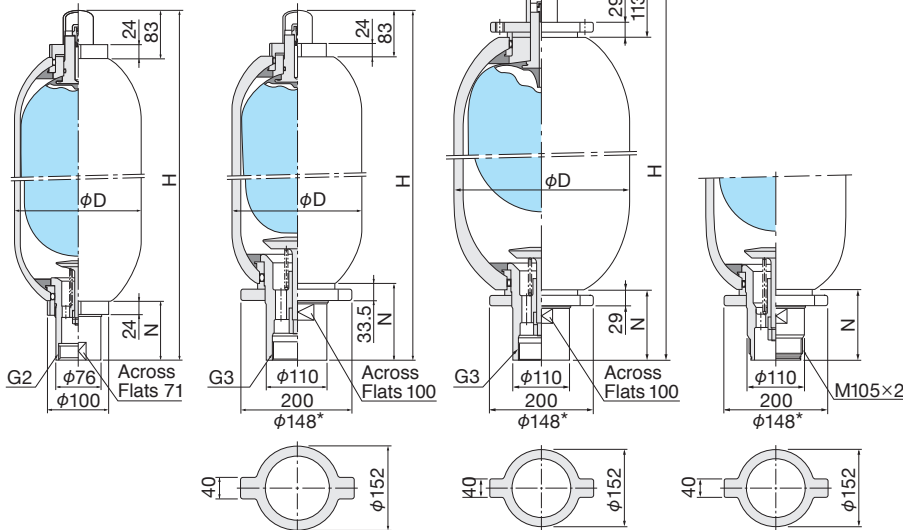

*: Dimensions of the CE Mark Products

Basic Model

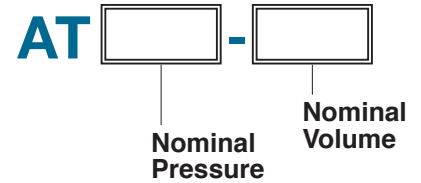

With TR CAP(10~60 ℓ)

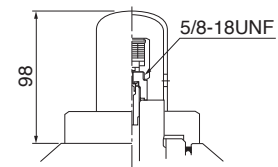

AT series Standard Flow Rate Models

The maximum working pressure will vary depending on the applicable regulations and standards.

Nominal Volume ℓ	Maximum Working Pressure (Applicable regulations and standards.)			Basic Model	Gas Volume ℓ	Mass kg	Dimension mm			Maximum Discharge Flow Rate ℓ/min
	Japan	China USA	EU				H (Note)	D	N	
10	16	18	180	AT18M-10	10	36	610(625)	223	102	600
	22.6	25	250	AT25M-10		40		229		
	34.3	35	350	AT35M-10		57	613(628)	245	99	
20	16	18	180	AT18M-20	19	52	912(927)	223	102	600
	22.6	25	250	AT25M-20		63		229		
	34.3	35	350	AT35M-20		91	915(930)	245	99	
30	16	18	180	AT18M-30	35	80	1432(1447)	223	102	600
	20.6	23	230	AT23M-30	35	96	1104(1119)	273		
	22.6	25	250	AT25M-30	34	100	1432(1447)	229		
	34.3	35	350	AT35M-30	34	149	1435(1450)	245		
40	20.6	23	230	AT23M-40	45	116	1324(1339)	273	102	600
50	16	18	180	AT18M-50	51	106	1950(1965)	223	102	600
	20.6	23	230	AT23M-50	55	138	1544(1559)	273		
	22.6	25	250	AT25M-50	50	137	1950(1965)	229		
60	20.6	23	230	AT23M-60	64	158	1764(1779)	273	102	600
80	20.6	23	230	AT23M-80	79	225	1452(1452)	356	138	1800
120	20.6	23	230	AT23M-120	129	329	2125(2125)	356	138	1800
150	20.6	23	230	AT23M-150	152	377	2435(2435)	356	138	1800
160	20.6	23	230	AT23M-160	158	389	2515(2515)	356	138	1800

AT23M-30,40,50,60 are short types.

Note: Values in brackets represent the dimensions with a TR cap attached.

Japanese Regulations Compliant Products

- Products Inspected In-house
- Products Compliant with the High Pressure Gas Safety Law
→ See pages 22 through 25 for Model Codes and Product Codes

Overseas Regulations and Standards Compliant Products

- USA: ASME U-Stamp Compliant Products
- EU : CE Mark Products
- China: Regulation for Boiler and Pressure Vessel Manufacture Licensing
→ See pages 26 through 28 for Model Codes and Product Codes

AT series High Flow Rate Models

The maximum working pressure will vary depending on the applicable regulations and standards.

Type	Maximum Discharge Flow Rate ℓ/min	Nominal Volume ℓ	Maximum Working Pressure (Applicable regulations and standards.)			Basic Model	Gas Volume ℓ	Mass kg	Dimension mm					
			Japan	China USA	EU				H (Note)	D	N			
			MPa	MPa	bar									
Semi High Flow (SH)	1260	10	16	18	180	AT18M-10- * -SH	10	36	610(625)	223	102			
			22.6	25	250	AT25M-10- * -SH		40		229				
			34.3	35	350	AT35M-10- * -SH		57		245		99		
		20	16	18	180	AT18M-20- * -SH	19	52	912(927)	223	102			
			22.6	25	250	AT25M-20- * -SH		63		229				
			34.3	35	350	AT35M-20- * -SH		91		245		99		
		30	16	18	180	AT18M-30- * -SH	35	80	1432(1447)	223	102			
			20.6	23	230	AT23M-30- * -SH	35	96	1104(1119)	273				
			22.6	25	250	AT25M-30- * -SH	34	100	1432(1447)	229				
		40	34.3	35	350	AT35M-30- * -SH	34	149	1435(1450)	245	99			
			20.6	23	230	AT23M-40- * -SH	45	116	1324(1339)	273	102			
			16	18	180	AT18M-50- * -SH	51	106	1950(1965)	223				
		50	20.6	23	230	AT23M-50- * -SH	55	138	1544(1559)	273				
			22.6	25	250	AT25M-50- * -SH	50	137	1950(1965)	229				
			20.6	23	230	AT23M-60- * -SH	64	158	1764(1779)	273				
High Flow (HF)	1800	10	22.6	25	250	AT25M-10- * -HF	10	48	657(672)	229	141			
		20				AT25M-20- * -HF	18	71	942(957)					
		30				AT25M-30- * -HF	33	108	1462(1477)					
		40				20.6	23	230	AT23M-40- * -HF	45	124	1358(1373)	273	143
		50				22.6	25	250	AT25M-50- * -HF	49	145	1980(1995)	229	141
Middle High Flow (MH)	2280	10	22.6	25	250	AT25M-10- * -MH	10	48	657(672)	229	141			
		20				AT25M-20- * -MH	18	71	942(957)					
		30				AT25M-30- * -MH	33	108	1462(1477)					
		40				20.6	23	230	AT23M-40- * -MH	45	124	1358(1373)	273	143
		50				22.6	25	250	AT25M-50- * -MH	49	145	1980(1995)	229	141
		80				20.6	23	230	AT23M-80- * -MH	79	225	1452(1452)	356	138
		120							AT23M-120- * -MH	129	329	2125(2125)		
		150							AT23M-150- * -MH	152	377	2435(2435)		
		160							AT23M-160- * -MH	158	389	2515(2515)		
Ultra High Flow (UH)	4800	10	22.6	25	250	AT25M-10- * -UH	10	48	657(672)	229	141			
		20				AT25M-20- * -UH	18	71	942(957)					
		30				AT25M-30- * -UH	33	108	1462(1477)					
		40				20.6	23	230	AT23M-40- * -UH	45	124	1358(1373)	273	143
		50				22.6	25	250	AT25M-50- * -UH	49	145	1980(1995)	229	141
		80				20.6	23	230	AT23M-80- * -UH	79	225	1452(1452)	356	138
		120							AT23M-120- * -UH	129	329	2125(2125)		
		150							AT23M-150- * -UH	152	377	2435(2435)		
		160							AT23M-160- * -UH	158	389	2515(2515)		

List of Model Codes and Dimensions

AT23M-30,40,50,60 are short types.

*: Symbol of Rubber Material Note: Values in brackets represent the dimensions with a TR cap attached.

To place an order from the AT series for Japan:

Ensure to specify the: (1) "Model Code" and (2) "Product Code" when placing an order.

(1) Example "Model Code" Configuration

Japanese Regulations Compliant Products

Standard Product: List of Model Codes and Product Codes

AT series Standard Flow Rate Models : 10, 20 ℓ

- Rubber Material: Symbol 30 (NBR Standard Nitrile Rubber)
- Applicable Fluid: Common Mineral Hydraulic Oil

Nominal Volume ℓ	Maximum Working Pressure MPa	Joint for Fluid Port Connecting	Size	Without TR CAP		With TR CAP	
				Model Code	Product Code *	Model Code	Product Code *
10	16	Bushing	R3/4	AT18M-10-30/T06	KY5000 <input type="checkbox"/> 0	AT18M-10-30/T06E	KY7000 <input type="checkbox"/> 0
			R1	/T08	KY5001 <input type="checkbox"/> 0	/T08E	KY7001 <input type="checkbox"/> 0
		F Type Flange	20A	/F06	KY5002 <input type="checkbox"/> 0	/F06E	KY7002 <input type="checkbox"/> 0

⇒ Maximum Working Pressure: 16 MPa, Volume: 10 ℓ, Connection Dimensions: R3/4, Joint for Fluid Port Connecting: Bushing

(2) Example "Product Code" Configuration

KY○○○○○ 0

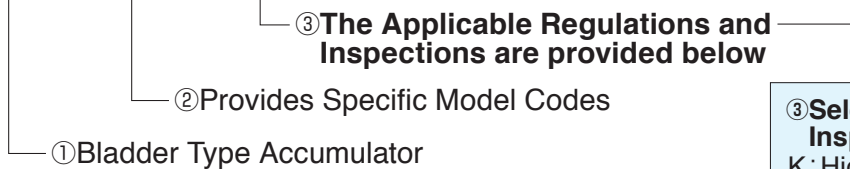

③ Select "Applicable Regulations and Inspections" from the Following:
 K: High Pressure Gas Safety Law (high pressure gas production equipment)
 S: In-house Inspection

(Example) **KY5000 K0:**

① Bladder Type Accumulator ② Model: AT18M-10-30/T06 ③ High Pressure Gas Safety Law

Japanese Regulations Compliant Products

Standard Product: List of Model Codes and Product Codes

AT series Standard Flow Rate Models: 10, 20 ℓ

- Rubber Material: Symbol 30 (NBR Standard Nitrile Rubber)
- Applicable Fluid: Common Mineral Hydraulic Oil

Nominal Volume ℓ	Maximum Working Pressure MPa	Joint for Fluid Port Connecting	Size	Without TR CAP		With TR CAP	
				Model Code	Product Code *	Model Code	Product Code *
10	16	Bushing	R3/4	AT18M-10-30/T06	KY5000 <input type="checkbox"/> 0	AT18M-10-30/T06E	KY7000 <input type="checkbox"/> 0
			R1	/T08	KY5001 <input type="checkbox"/> 0	/T08E	KY7001 <input type="checkbox"/> 0
		F Type Flange	20A	/F06	KY5002 <input type="checkbox"/> 0	/F06E	KY7002 <input type="checkbox"/> 0
	22.6	Bushing	R3/4	AT25M-10-30/T06	KY5003 <input type="checkbox"/> 0	AT25M-10-30/T06E	KY7003 <input type="checkbox"/> 0
			R1	/T08	KY5004 <input type="checkbox"/> 0	/T08E	KY7004 <input type="checkbox"/> 0
		F Type Flange	20A	/F06	KY5005 <input type="checkbox"/> 0	/F06E	KY7005 <input type="checkbox"/> 0
	34.3	Bushing	R3/4	AT35M-10-30/T06	KY5006 <input type="checkbox"/> 0	AT35M-10-30/T06E	KY7006 <input type="checkbox"/> 0
			R1	/T08	KY5007 <input type="checkbox"/> 0	/T08E	KY7007 <input type="checkbox"/> 0
		H Type Flange	20A	/H06	KY5008 <input type="checkbox"/> 0	/H06E	KY7008 <input type="checkbox"/> 0
20	16	Bushing	R3/4	AT18M-20-30/T06	KY5009 <input type="checkbox"/> 0	AT18M-20-30/T06E	KY7009 <input type="checkbox"/> 0
			R1	/T08	KY5010 <input type="checkbox"/> 0	/T08E	KY7010 <input type="checkbox"/> 0
		F Type Flange	20A	/F06	KY5011 <input type="checkbox"/> 0	/F06E	KY7011 <input type="checkbox"/> 0
	22.6	Bushing	R3/4	AT25M-20-30/T06	KY5012 <input type="checkbox"/> 0	AT25M-20-30/T06E	KY7012 <input type="checkbox"/> 0
			R1	/T08	KY5013 <input type="checkbox"/> 0	/T08E	KY7013 <input type="checkbox"/> 0
		F Type Flange	20A	/F06	KY5014 <input type="checkbox"/> 0	/F06E	KY7014 <input type="checkbox"/> 0
	34.3	Bushing	R3/4	AT35M-20-30/T06	KY5015 <input type="checkbox"/> 0	AT35M-20-30/T06E	KY7015 <input type="checkbox"/> 0
			R1	/T08	KY5016 <input type="checkbox"/> 0	/T08E	KY7016 <input type="checkbox"/> 0
		H Type Flange	20A	/H06	KY5017 <input type="checkbox"/> 0	/H06E	KY7017 <input type="checkbox"/> 0

Please designate Model Code and Product Code in your order. *Select K (high pressure gas) or S (in-house inspection) with regard to of the Product Code.

■ Standard Product: List of Model Codes and Product Codes

AT series Standard Flow Rate Models: 30,40,50,60 ℓ ●Rubber Material: Symbol 30(NBR Standard Nitrile Rubber) ●Applicable Fluid: Common Mineral Hydraulic Oil

Nominal Volume ℓ	Maximum Working Pressure MPa	Joint for Fluid Port Connecting	Size	Without TR CAP		With TR CAP	
				Model Code	Product Code *	Model Code	Product Code *
30	16	Bushing	R3/4	AT18M-30-30/T06	KY5018 <input type="checkbox"/>	AT18M-30-30/T06E	KY7018 <input type="checkbox"/>
			R1	/T08	KY5019 <input type="checkbox"/>	/T08E	KY7019 <input type="checkbox"/>
		F Type Flange	20A	/F06	KY5020 <input type="checkbox"/>	/F06E	KY7020 <input type="checkbox"/>
	20.6	Bushing	R3/4	AT23M-30-30/T06	KY5021 <input type="checkbox"/>	AT23M-30-30/T06E	KY7021 <input type="checkbox"/>
			R1	/T08	KY5022 <input type="checkbox"/>	/T08E	KY7022 <input type="checkbox"/>
		F Type Flange	20A	/F06	KY5023 <input type="checkbox"/>	/F06E	KY7023 <input type="checkbox"/>
	22.6	Bushing	R3/4	AT25M-30-30/T06	KY5024 <input type="checkbox"/>	AT25M-30-30/T06E	KY7024 <input type="checkbox"/>
			R1	/T08	KY5025 <input type="checkbox"/>	/T08E	KY7025 <input type="checkbox"/>
		F Type Flange	20A	/F06	KY5026 <input type="checkbox"/>	/F06E	KY7026 <input type="checkbox"/>
	34.3	Bushing	R3/4	AT35M-30-30/T06	KY5027 <input type="checkbox"/>	AT35M-30-30/T06E	KY7027 <input type="checkbox"/>
			R1	/T08	KY5028 <input type="checkbox"/>	/T08E	KY7028 <input type="checkbox"/>
		H Type Flange	20A	/H06	KY5029 <input type="checkbox"/>	/H06E	KY7029 <input type="checkbox"/>
40	20.6	Bushing	R3/4	AT23M-40-30/T06	KY5030 <input type="checkbox"/>	AT23M-40-30/T06E	KY7030 <input type="checkbox"/>
			R1	/T08	KY5031 <input type="checkbox"/>	/T08E	KY7031 <input type="checkbox"/>
		F Type Flange	20A	/F06	KY5032 <input type="checkbox"/>	/F06E	KY7032 <input type="checkbox"/>
50	16	Bushing	R3/4	AT18M-50-30/T06	KY5033 <input type="checkbox"/>	AT18M-50-30/T06E	KY7033 <input type="checkbox"/>
			R1	/T08	KY5034 <input type="checkbox"/>	/T08E	KY7034 <input type="checkbox"/>
		F Type Flange	20A	/F06	KY5035 <input type="checkbox"/>	/F06E	KY7035 <input type="checkbox"/>
	20.6	Bushing	R3/4	AT23M-50-30/T06	KY5036 <input type="checkbox"/>	AT23M-50-30/T06E	KY7036 <input type="checkbox"/>
			R1	/T08	KY5037 <input type="checkbox"/>	/T08E	KY7037 <input type="checkbox"/>
		F Type Flange	20A	/F06	KY5038 <input type="checkbox"/>	/F06E	KY7038 <input type="checkbox"/>
22.6	Bushing	R3/4	AT25M-50-30/T06	KY5039 <input type="checkbox"/>	AT25M-50-30/T06E	KY7039 <input type="checkbox"/>	
		R1	/T08	KY5040 <input type="checkbox"/>	/T08E	KY7040 <input type="checkbox"/>	
60	20.6	Bushing	R3/4	AT23M-60-30/T06	KY5042 <input type="checkbox"/>	AT23M-60-30/T06E	KY7042 <input type="checkbox"/>
			R1	/T08	KY5043 <input type="checkbox"/>	/T08E	KY7043 <input type="checkbox"/>
F Type Flange		20A	/F06	KY5044 <input type="checkbox"/>	/F06E	KY7044 <input type="checkbox"/>	

Please designate Model Code and Product Code in your order. *Select K (high pressure gas) or S (in-house inspection) with regard to of the Product Code.

AT series Standard Flow Rate Models: 80,120,150,160 ℓ ●Rubber Material: Symbol 30(NBR Standard Nitrile Rubber) ●Applicable Fluid: Common Mineral Hydraulic Oil

Nominal Volume ℓ	Maximum Working Pressure MPa	Joint for Fluid Port Connecting	Size	Without TR CAP		With TR CAP	
				Model Code	Product Code *	Model Code	Product Code *
80	20.6	F Type Flange	40A	AT23M-80-30/F12	KY5045 <input type="checkbox"/>	AT23M-80-30/F12E	KY7045 <input type="checkbox"/>
			50A	/F16	KY5046 <input type="checkbox"/>	/F16E	KY7046 <input type="checkbox"/>
			D Type Flange	50A	/D16	KY5047 <input type="checkbox"/>	/D16E
120	20.6	F Type Flange	40A	AT23M-120-30/F12	KY5048 <input type="checkbox"/>	AT23M-120-30/F12E	KY7048 <input type="checkbox"/>
			50A	/F16	KY5049 <input type="checkbox"/>	/F16E	KY7049 <input type="checkbox"/>
			D Type Flange	50A	/D16	KY5050 <input type="checkbox"/>	/D16E
150	20.6	F Type Flange	40A	AT23M-150-30/F12	KY5051 <input type="checkbox"/>	AT23M-150-30/F12E	KY7051 <input type="checkbox"/>
			50A	/F16	KY5052 <input type="checkbox"/>	/F16E	KY7052 <input type="checkbox"/>
			D Type Flange	50A	/D16	KY5053 <input type="checkbox"/>	/D16E
160	20.6	F Type Flange	40A	AT23M-160-30/F12	KY5054 <input type="checkbox"/>	AT23M-160-30/F12E	KY7054 <input type="checkbox"/>
			50A	/F16	KY5055 <input type="checkbox"/>	/F16E	KY7055 <input type="checkbox"/>
			D Type Flange	50A	/D16	KY5056 <input type="checkbox"/>	/D16E

Please designate Model Code and Product Code in your order. *Select K (high pressure gas) or S (in-house inspection) with regard to of the Product Code.

■ Standard Product: List of Model Codes and Product Codes

AT series Semi High Flow (SH) Type

- Rubber Material: Symbol 30 (NBR Standard Nitrile Rubber)
- Applicable Fluid: Common Mineral Hydraulic Oil

Nominal Volume ℓ	Maximum Working Pressure MPa	Joint for Fluid Port Connecting	Size	Without TR CAP		With TR CAP	
				Model Code	Product Code*	Model Code	Product Code*
10	16	F Type Flange	32A	AT18M-10-30-SH/F10	KY5057 <input type="checkbox"/> 0	AT18M-10-30-SH/F10E	KY7057 <input type="checkbox"/> 0
	22.6	F Type Flange		AT25M-10-30-SH/F10	KY5058 <input type="checkbox"/> 0	AT25M-10-30-SH/F10E	KY7058 <input type="checkbox"/> 0
	34.3	H Type Flange		AT35M-10-30-SH/H10	KY5059 <input type="checkbox"/> 0	AT35M-10-30-SH/H10E	KY7059 <input type="checkbox"/> 0
20	16	F Type Flange		AT18M-20-30-SH/F10	KY5060 <input type="checkbox"/> 0	AT18M-20-30-SH/F10E	KY7060 <input type="checkbox"/> 0
	22.6	F Type Flange		AT25M-20-30-SH/F10	KY5061 <input type="checkbox"/> 0	AT25M-20-30-SH/F10E	KY7061 <input type="checkbox"/> 0
	34.3	H Type Flange		AT35M-20-30-SH/H10	KY5062 <input type="checkbox"/> 0	AT35M-20-30-SH/H10E	KY7062 <input type="checkbox"/> 0
30	16	F Type Flange		AT18M-30-30-SH/F10	KY5063 <input type="checkbox"/> 0	AT18M-30-30-SH/F10E	KY7063 <input type="checkbox"/> 0
	20.6			AT23M-30-30-SH/F10	KY5064 <input type="checkbox"/> 0	AT23M-30-30-SH/F10E	KY7064 <input type="checkbox"/> 0
	22.6	H Type Flange		AT25M-30-30-SH/F10	KY5065 <input type="checkbox"/> 0	AT25M-30-30-SH/F10E	KY7065 <input type="checkbox"/> 0
	34.3			AT35M-30-30-SH/H10	KY5066 <input type="checkbox"/> 0	AT35M-30-30-SH/H10E	KY7066 <input type="checkbox"/> 0
40	20.6	F Type Flange		AT23M-40-30-SH/F10	KY5067 <input type="checkbox"/> 0	AT23M-40-30-SH/F10E	KY7067 <input type="checkbox"/> 0
50	16	F Type Flange		AT18M-50-30-SH/F10	KY5068 <input type="checkbox"/> 0	AT18M-50-30-SH/F10E	KY7068 <input type="checkbox"/> 0
	20.6		AT23M-50-30-SH/F10	KY5069 <input type="checkbox"/> 0	AT23M-50-30-SH/F10E	KY7069 <input type="checkbox"/> 0	
	22.6		AT25M-50-30-SH/F10	KY5070 <input type="checkbox"/> 0	AT25M-50-30-SH/F10E	KY7070 <input type="checkbox"/> 0	
60	20.6	F Type Flange	AT23M-60-30-SH/F10	KY5071 <input type="checkbox"/> 0	AT23M-60-30-SH/F10E	KY7071 <input type="checkbox"/> 0	

Please designate Model Code and Product Code in your order. *Select K (high pressure gas) or S (in-house inspection) with regard to of the Product Code.

AT series High Flow (HF) Type

- Rubber Material: Symbol 30 (NBR Standard Nitrile Rubber)
- Applicable Fluid: Common Mineral Hydraulic Oil

Nominal Volume ℓ	Maximum Working Pressure MPa	Joint for Fluid Port Connecting	Size	Without TR CAP		With TR CAP	
				Model Code	Product Code*	Model Code	Product Code*
10	22.6	F Type Flange	50A	AT25M-10-30-HF/F16	KY5072 <input type="checkbox"/> 0	AT25M-10-30-HF/F16E	KY7072 <input type="checkbox"/> 0
		D Type Flange		/D16	KY5073 <input type="checkbox"/> 0	/D16E	KY7073 <input type="checkbox"/> 0
F Type Flange		AT25M-20-30-HF/F16		KY5074 <input type="checkbox"/> 0	AT25M-20-30-HF/F16E	KY7074 <input type="checkbox"/> 0	
D Type Flange		/D16		KY5075 <input type="checkbox"/> 0	/D16E	KY7075 <input type="checkbox"/> 0	
20	20.6	F Type Flange		AT25M-30-30-HF/F16	KY5076 <input type="checkbox"/> 0	AT25M-30-30-HF/F16E	KY7076 <input type="checkbox"/> 0
		D Type Flange		/D16	KY5077 <input type="checkbox"/> 0	/D16E	KY7077 <input type="checkbox"/> 0
30	20.6	F Type Flange		AT23M-40-30-HF/F16	KY5078 <input type="checkbox"/> 0	AT23M-40-30-HF/F16E	KY7078 <input type="checkbox"/> 0
		D Type Flange		/D16	KY5079 <input type="checkbox"/> 0	/D16E	KY7079 <input type="checkbox"/> 0
40	22.6	F Type Flange		AT25M-50-30-HF/F16	KY5080 <input type="checkbox"/> 0	AT25M-50-30-HF/F16E	KY7080 <input type="checkbox"/> 0
		D Type Flange		/D16	KY5081 <input type="checkbox"/> 0	/D16E	KY7081 <input type="checkbox"/> 0

Please designate Model Code and Product Code in your order. *Select K (high pressure gas) or S (in-house inspection) with regard to of the Product Code.

AT series Middle High Flow (MH) Type

- Rubber Material: Symbol 30 (NBR Standard Nitrile Rubber)
- Applicable Fluid: Common Mineral Hydraulic Oil

Nominal Volume ℓ	Maximum Working Pressure MPa	Joint for Fluid Port Connecting	Size	Without TR CAP		With TR CAP		
				Model Code	Product Code*	Model Code	Product Code*	
10	22.6	F Type Flange	65A	AT25M-10-30-MH/F20	KY5082 <input type="checkbox"/> 0	AT25M-10-30-MH/F20E	KY7082 <input type="checkbox"/> 0	
		D Type Flange		/D20	KY5083 <input type="checkbox"/> 0	/D20E	KY7083 <input type="checkbox"/> 0	
F Type Flange		AT25M-20-30-MH/F20		KY5084 <input type="checkbox"/> 0	AT25M-20-30-MH/F20E	KY7084 <input type="checkbox"/> 0		
D Type Flange		/D20		KY5085 <input type="checkbox"/> 0	/D20E	KY7085 <input type="checkbox"/> 0		
20		20.6		F Type Flange	AT25M-30-30-MH/F20	KY5086 <input type="checkbox"/> 0	AT25M-30-30-MH/F20E	KY7086 <input type="checkbox"/> 0
				D Type Flange	/D20	KY5087 <input type="checkbox"/> 0	/D20E	KY7087 <input type="checkbox"/> 0
30	20.6	F Type Flange		AT23M-40-30-MH/F20	KY5088 <input type="checkbox"/> 0	AT23M-40-30-MH/F20E	KY7088 <input type="checkbox"/> 0	
		D Type Flange		/D20	KY5089 <input type="checkbox"/> 0	/D20E	KY7089 <input type="checkbox"/> 0	
40	22.6	F Type Flange		AT25M-50-30-MH/F20	KY5090 <input type="checkbox"/> 0	AT25M-50-30-MH/F20E	KY7090 <input type="checkbox"/> 0	
		D Type Flange		/D20	KY5091 <input type="checkbox"/> 0	/D20E	KY7091 <input type="checkbox"/> 0	
80	20.6	F Type Flange		AT23M-80-30-MH/F20	KY5092 <input type="checkbox"/> 0	AT23M-80-30-MH/F20E	KY7092 <input type="checkbox"/> 0	
		D Type Flange		/D20	KY5093 <input type="checkbox"/> 0	/D20E	KY7093 <input type="checkbox"/> 0	
120		F Type Flange	AT23M-120-30-MH/F20	KY5094 <input type="checkbox"/> 0	AT23M-120-30-MH/F20E	KY7094 <input type="checkbox"/> 0		
			D Type Flange	/D20	KY5095 <input type="checkbox"/> 0	/D20E	KY7095 <input type="checkbox"/> 0	
150		F Type Flange	AT23M-150-30-MH/F20	KY5096 <input type="checkbox"/> 0	AT23M-150-30-MH/F20E	KY7096 <input type="checkbox"/> 0		
			D Type Flange	/D20	KY5097 <input type="checkbox"/> 0	/D20E	KY7097 <input type="checkbox"/> 0	
160	F Type Flange	AT23M-160-30-MH/F20	KY5098 <input type="checkbox"/> 0	AT23M-160-30-MH/F20E	KY7098 <input type="checkbox"/> 0			
		D Type Flange	/D20	KY5099 <input type="checkbox"/> 0	/D20E	KY7099 <input type="checkbox"/> 0		

Please designate Model Code and Product Code in your order. *Select K (high pressure gas) or S (in-house inspection) with regard to of the Product Code.

■ Standard Product: List of Model Codes and Product Codes

AT series Ultra High Flow (UH) Type

- Rubber Material: Symbol 30 (NBR Standard Nitrile Rubber)
- Applicable Fluid: Common Mineral Hydraulic Oil

Nominal Volume ℓ	Maximum Working Pressure MPa	Joint for Fluid Port Connecting	Size	Without TR CAP		With TR CAP	
				Model Code	Product Code*	Model Code	Product Code*
10	22.6	D Type Flange	80A	AT25M-10-30-UH/D24	KY5100 □0	AT25M-10-30-UH/D24E	KY7100 □0
20				AT25M-20-30-UH/D24	KY5101 □0	AT25M-20-30-UH/D24E	KY7101 □0
30				AT25M-30-30-UH/D24	KY5102 □0	AT25M-30-30-UH/D24E	KY7102 □0
40	20.6			AT23M-40-30-UH/D24	KY5103 □0	AT23M-40-30-UH/D24E	KY7103 □0
50	22.6			AT25M-50-30-UH/D24	KY5104 □0	AT25M-50-30-UH/D24E	KY7104 □0
80	20.6			AT23M-80-30-UH/D24	KY5105 □0	AT23M-80-30-UH/D24E	KY7105 □0
120				AT23M-120-30-UH/D24	KY5106 □0	AT23M-120-30-UH/D24E	KY7106 □0
150				AT23M-150-30-UH/D24	KY5107 □0	AT23M-150-30-UH/D24E	KY7107 □0
160				AT23M-160-30-UH/D24	KY5108 □0	AT23M-160-30-UH/D24E	KY7108 □0

Please designate Model Code and Product Code in your order. *Select K (high pressure gas) or S (in-house inspection) with regard to □ of the Product Code.

To place an order from the AT series for overseas:

Ensure to specify the: (1) "Model Code" and (2) "Product Code" when placing an order.

(1) Example "Model Code" Configuration

Overseas Regulations and Standards Compliant Products

Standard Product: List of Model Codes and Product Codes

AT series Standard Flow Rate Models : 10, 20 ℓ

- Rubber Material: Symbol 30 (NBR Standard Nitrile Rubber)
- Applicable Fluid: Common Mineral Hydraulic Oil

Nominal Volume ℓ	Maximum Working Pressure MPa	Joint for Fluid Port Connecting	Size	Without TR CAP		With TR CAP ^(Note)	
				Model Code	Product Code *	Model Code	Product Code *
10	18	Bushing	R3/4	AT18M-10-30/T06	KY5000 <input type="checkbox"/> 0	AT18M-10-30/T06E	KY7000 <input type="checkbox"/> 0
			R1	/T08	KY5001 <input type="checkbox"/> 0	/T08E	KY7001 <input type="checkbox"/> 0
		F Type Flange	20A	/F06	KY5002 <input type="checkbox"/> 0	/F06E	KY7002 <input type="checkbox"/> 0

⇒ Maximum Working Pressure: 18 MPa, Volume: 10 ℓ, Connection Dimensions: R3/4, Joint for Fluid Port Connecting: Bushing

(2) Example "Product Code" Configuration

KY○○○○○ 0

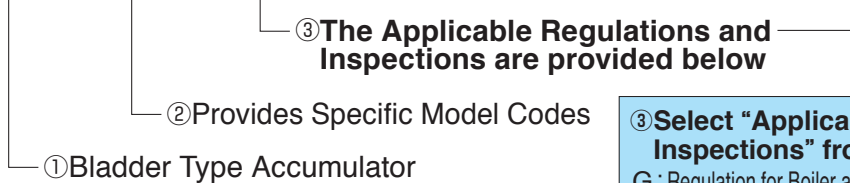

③ Select "Applicable Regulations and Inspections" from the Following:
 G : Regulation for Boiler and Pressure Vessel Manufacture Licensing (China)
 U : ASME U-Stamp (American Society of Mechanical Engineers)
 E : CE Mark (European Pressure Equipment Directive)

(Example) **KY5000 K0:**

① Bladder Type Accumulator ② Model: AT18M-10-30/T06 ③ CE Mark Compliant

Overseas Regulations and Standards Compliant Products

Standard Product: List of Model Codes and Product Codes

AT series Standard Flow Rate Models: 10, 20 ℓ

- Rubber Material: Symbol 30 (NBR Standard Nitrile Rubber)
- Applicable Fluid: Common Mineral Hydraulic Oil

Nominal Volume ℓ	Maximum Working Pressure MPa	Joint for Fluid Port Connecting	Size	Without TR CAP		With TR CAP ^(Note)	
				Model Code	Product Code *	Model Code	Product Code *
10	18	Bushing	R3/4	AT18M-10-30/T06	KY5000 <input type="checkbox"/> 0	AT18M-10-30/T06E	KY7000 <input type="checkbox"/> 0
			R1	/T08	KY5001 <input type="checkbox"/> 0	/T08E	KY7001 <input type="checkbox"/> 0
		F Type Flange	20A	/F06	KY5002 <input type="checkbox"/> 0	/F06E	KY7002 <input type="checkbox"/> 0
	25	Bushing	R3/4	AT25M-10-30/T06	KY5003 <input type="checkbox"/> 0	AT25M-10-30/T06E	KY7003 <input type="checkbox"/> 0
			R1	/T08	KY5004 <input type="checkbox"/> 0	/T08E	KY7004 <input type="checkbox"/> 0
		F Type Flange	20A	/F06	KY5005 <input type="checkbox"/> 0	/F06E	KY7005 <input type="checkbox"/> 0
	35	Bushing	R3/4	AT35M-10-30/T06	KY5006 <input type="checkbox"/> 0	AT35M-10-30/T06E	KY7006 <input type="checkbox"/> 0
			R1	/T08	KY5007 <input type="checkbox"/> 0	/T08E	KY7007 <input type="checkbox"/> 0
		H Type Flange	20A	/H06	KY5008 <input type="checkbox"/> 0	/H06E	KY7008 <input type="checkbox"/> 0
20	18	Bushing	R3/4	AT18M-20-30/T06	KY5009 <input type="checkbox"/> 0	AT18M-20-30/T06E	KY7009 <input type="checkbox"/> 0
			R1	/T08	KY5010 <input type="checkbox"/> 0	T08E	KY7010 <input type="checkbox"/> 0
		F Type Flange	20A	/F06	KY5011 <input type="checkbox"/> 0	/F06E	KY7011 <input type="checkbox"/> 0
	25	Bushing	R3/4	AT25M-20-30/T06	KY5012 <input type="checkbox"/> 0	AT25M-20-30/T06E	KY7012 <input type="checkbox"/> 0
			R1	/T08	KY5013 <input type="checkbox"/> 0	/T08E	KY7013 <input type="checkbox"/> 0
		F Type Flange	20A	/F06	KY5014 <input type="checkbox"/> 0	/F06E	KY7014 <input type="checkbox"/> 0
	35	Bushing	R3/4	AT35M-20-30/T06	KY5015 <input type="checkbox"/> 0	AT35M-20-30/T06E	KY7015 <input type="checkbox"/> 0
			R1	/T08	KY5016 <input type="checkbox"/> 0	/T08E	KY7016 <input type="checkbox"/> 0
		H Type Flange	20A	/H06	KY5017 <input type="checkbox"/> 0	/H06E	KY7017 <input type="checkbox"/> 0

Please designate Model Code and Product Code in your order.

*Select E (CE Mark), U (ASME U-Stamp) or G (Regulation for Boiler and Pressure Vessel Manufacture Licensing) with regard to of the Product Code. Note: CE Mark models are not available for any models with a TR cap.

Standard Product: List of Model Codes and Product Codes

AT series Standard Flow Rate Models: 30, 40, 50, 60 ℓ ● Rubber Material: Symbol 30 (NBR Standard Nitrile Rubber) ● Applicable Fluid: Common Mineral Hydraulic Oil

Nominal Volume ℓ	Maximum Working Pressure MPa	Joint for Fluid Port Connecting	Size	Without TR CAP		With TR CAP ^(Note)	
				Model Code	Product Code*	Model Code	Product Code*
30	18	Bushing	R3/4	AT18M-30-30/T06	KY5018 <input type="checkbox"/> 0	AT18M-30-30/T06E	KY7018 <input type="checkbox"/> 0
			R1	/T08	KY5019 <input type="checkbox"/> 0	/T08E	KY7019 <input type="checkbox"/> 0
		F Type Flange	20A	/F06	KY5020 <input type="checkbox"/> 0	/F06E	KY7020 <input type="checkbox"/> 0
	23	Bushing	R3/4	AT23M-30-30/T06	KY5021 <input type="checkbox"/> 0	AT23M-30-30/T06E	KY7021 <input type="checkbox"/> 0
			R1	/T08	KY5022 <input type="checkbox"/> 0	/T08E	KY7022 <input type="checkbox"/> 0
		F Type Flange	20A	/F06	KY5023 <input type="checkbox"/> 0	/F06E	KY7023 <input type="checkbox"/> 0
	25	Bushing	R3/4	AT25M-30-30/T06	KY5024 <input type="checkbox"/> 0	AT25M-30-30/T06E	KY7024 <input type="checkbox"/> 0
			R1	/T08	KY5025 <input type="checkbox"/> 0	/T08E	KY7025 <input type="checkbox"/> 0
		F Type Flange	20A	/F06	KY5026 <input type="checkbox"/> 0	/F06E	KY7026 <input type="checkbox"/> 0
	35	Bushing	R3/4	AT35M-30-30/T06	KY5027 <input type="checkbox"/> 0	AT35M-30-30/T06E	KY7027 <input type="checkbox"/> 0
			R1	/T08	KY5028 <input type="checkbox"/> 0	/T08E	KY7028 <input type="checkbox"/> 0
		H Type Flange	20A	/H06	KY5029 <input type="checkbox"/> 0	/H06E	KY7029 <input type="checkbox"/> 0
40	23	Bushing	R3/4	AT23M-40-30/T06	KY5030 <input type="checkbox"/> 0	AT23M-40-30/T06E	KY7030 <input type="checkbox"/> 0
			R1	/T08	KY5031 <input type="checkbox"/> 0	/T08E	KY7031 <input type="checkbox"/> 0
		F Type Flange	20A	/F06	KY5032 <input type="checkbox"/> 0	/F06E	KY7032 <input type="checkbox"/> 0
50	18	Bushing	R3/4	AT18M-50-30/T06	KY5033 <input type="checkbox"/> 0	AT18M-50-30/T06E	KY7033 <input type="checkbox"/> 0
			R1	/T08	KY5034 <input type="checkbox"/> 0	/T08E	KY7034 <input type="checkbox"/> 0
		F Type Flange	20A	/F06	KY5035 <input type="checkbox"/> 0	/F06E	KY7035 <input type="checkbox"/> 0
	23	Bushing	R3/4	AT23M-50-30/T06	KY5036 <input type="checkbox"/> 0	AT23M-50-30/T06E	KY7036 <input type="checkbox"/> 0
			R1	/T08	KY5037 <input type="checkbox"/> 0	/T08E	KY7037 <input type="checkbox"/> 0
		F Type Flange	20A	/F06	KY5038 <input type="checkbox"/> 0	/F06E	KY7038 <input type="checkbox"/> 0
25	Bushing	R3/4	AT25M-50-30/T06	KY5039 <input type="checkbox"/> 0	AT25M-50-30/T06E	KY7039 <input type="checkbox"/> 0	
		R1	/T08	KY5040 <input type="checkbox"/> 0	/T08E	KY7040 <input type="checkbox"/> 0	
	F Type Flange	20A	/F06	KY5041 <input type="checkbox"/> 0	/F06E	KY7041 <input type="checkbox"/> 0	
60	23	Bushing	R3/4	AT23M-60-30/T06	KY5042 <input type="checkbox"/> 0	AT23M-60-30/T06E	KY7042 <input type="checkbox"/> 0
			R1	/T08	KY5043 <input type="checkbox"/> 0	/T08E	KY7043 <input type="checkbox"/> 0
		F Type Flange	20A	/F06	KY5044 <input type="checkbox"/> 0	/F06E	KY7044 <input type="checkbox"/> 0

Please designate Model Code and Product Code in your order. *Select E (CE Mark), U (ASME U-Stamp) or G (Regulation for Boiler and Pressure Vessel Manufacture Licensing) with regard to of the Product Code. Note: CE Mark models are not available for any models with a TR cap.

AT series Standard Flow Rate Models: 80, 120, 150, 160 ℓ ● Rubber Material: Symbol 30 (NBR Standard Nitrile Rubber) ● Applicable Fluid: Common Mineral Hydraulic Oil

Nominal Volume ℓ	Maximum Working Pressure MPa	Joint for Fluid Port Connecting	Size	Without TR CAP		With TR CAP ^(Note)	
				Model Code	Product Code*	Model Code	Product Code*
80	23	F Type Flange	40A	AT23M-80-30/F12	KY5045 <input type="checkbox"/> 0	AT23M-80-30/F12E	KY7045 <input type="checkbox"/> 0
			50A	/F16	KY5046 <input type="checkbox"/> 0	/F16E	KY7046 <input type="checkbox"/> 0
		D Type Flange	50A	/D16	KY5047 <input type="checkbox"/> 0	/D16E	KY7047 <input type="checkbox"/> 0
120	23	F Type Flange	40A	AT23M-120-30/F12	KY5048 <input type="checkbox"/> 0	AT23M-120-30/F12E	KY7048 <input type="checkbox"/> 0
			50A	/F16	KY5049 <input type="checkbox"/> 0	/F16E	KY7049 <input type="checkbox"/> 0
		D Type Flange	50A	/D16	KY5050 <input type="checkbox"/> 0	/D16E	KY7050 <input type="checkbox"/> 0
150	23	F Type Flange	40A	AT23M-150-30/F12	KY5051 <input type="checkbox"/> 0	AT23M-150-30/F12E	KY7051 <input type="checkbox"/> 0
			50A	/F16	KY5052 <input type="checkbox"/> 0	/F16E	KY7052 <input type="checkbox"/> 0
		D Type Flange	50A	/D16	KY5053 <input type="checkbox"/> 0	/D16E	KY7053 <input type="checkbox"/> 0
160	23	F Type Flange	40A	AT23M-160-30/F12	KY5054 <input type="checkbox"/> 0	AT23M-160-30/F12E	KY7054 <input type="checkbox"/> 0
			50A	/F16	KY5055 <input type="checkbox"/> 0	/F16E	KY7055 <input type="checkbox"/> 0
		D Type Flange	50A	/D16	KY5056 <input type="checkbox"/> 0	/D16E	KY7056 <input type="checkbox"/> 0

Please designate Model Code and Product Code in your order. *Select E (CE Mark), U (ASME U-Stamp) or G (Regulation for Boiler and Pressure Vessel Manufacture Licensing) with regard to of the Product Code. Note: CE Mark models are not available for any models with a TR cap.

AT series Semi High Flow (SH) Type

● Rubber Material: Symbol 30 (NBR Standard Nitrile Rubber) ● Applicable Fluid: Common Mineral Hydraulic Oil

Nominal Volume ℓ	Maximum Working Pressure MPa	Joint for Fluid Port Connecting	Size	Without TR CAP		With TR CAP ^(Note)	
				Model Code	Product Code*	Model Code	Product Code*
10	18	F Type Flange	32A	AT18M-10-30-SH/F10	KY5057 <input type="checkbox"/> 0	AT18M-10-30-SH/F10E	KY7057 <input type="checkbox"/> 0
	25			AT25M-10-30-SH/F10	KY5058 <input type="checkbox"/> 0	AT25M-10-30-SH/F10E	KY7058 <input type="checkbox"/> 0
	35			AT35M-10-30-SH/H10	KY5059 <input type="checkbox"/> 0	AT35M-10-30-SH/H10E	KY7059 <input type="checkbox"/> 0
20	18	F Type Flange		AT18M-20-30-SH/F10	KY5060 <input type="checkbox"/> 0	AT18M-20-30-SH/F10E	KY7060 <input type="checkbox"/> 0
	25			AT25M-20-30-SH/F10	KY5061 <input type="checkbox"/> 0	AT25M-20-30-SH/F10E	KY7061 <input type="checkbox"/> 0
	35			AT35M-20-30-SH/H10	KY5062 <input type="checkbox"/> 0	AT35M-20-30-SH/H10E	KY7062 <input type="checkbox"/> 0
30	18	F Type Flange	AT18M-30-30-SH/F10	KY5063 <input type="checkbox"/> 0	AT18M-30-30-SH/F10E	KY7063 <input type="checkbox"/> 0	
	23		AT23M-30-30-SH/F10	KY5064 <input type="checkbox"/> 0	AT23M-30-30-SH/F10E	KY7064 <input type="checkbox"/> 0	
	25		AT25M-30-30-SH/F10	KY5065 <input type="checkbox"/> 0	AT25M-30-30-SH/F10E	KY7065 <input type="checkbox"/> 0	
40	35	H Type Flange	AT35M-30-30-SH/H10	KY5066 <input type="checkbox"/> 0	AT35M-30-30-SH/H10E	KY7066 <input type="checkbox"/> 0	
	23	F Type Flange	AT23M-40-30-SH/F10	KY5067 <input type="checkbox"/> 0	AT23M-40-30-SH/F10E	KY7067 <input type="checkbox"/> 0	
			AT18M-50-30-SH/F10	KY5068 <input type="checkbox"/> 0	AT18M-50-30-SH/F10E	KY7068 <input type="checkbox"/> 0	
AT23M-50-30-SH/F10			KY5069 <input type="checkbox"/> 0	AT23M-50-30-SH/F10E	KY7069 <input type="checkbox"/> 0		
50	25	F Type Flange	AT25M-50-30-SH/F10	KY5070 <input type="checkbox"/> 0	AT25M-50-30-SH/F10E	KY7070 <input type="checkbox"/> 0	
	23		AT23M-60-30-SH/F10	KY5071 <input type="checkbox"/> 0	AT23M-60-30-SH/F10E	KY7071 <input type="checkbox"/> 0	

Please designate Model Code and Product Code in your order. *Select E (CE Mark), U (ASME U-Stamp) or G (Regulation for Boiler and Pressure Vessel Manufacture Licensing) with regard to of the Product Code. Note: CE Mark models are not available for any models with a TR cap.

List of Model Codes and Dimensions

Standard Product: List of Model Codes and Product Codes

AT series High Flow (HF) Type

- Rubber Material: Symbol 30 (NBR Standard Nitrile Rubber)
- Applicable Fluid: Common Mineral Hydraulic Oil

Nominal Volume ℓ	Maximum Working Pressure MPa	Joint for Fluid Port Connecting	Size	Without TR CAP		With TR CAP (Note)	
				Model Code	Product Code *	Model Code	Product Code *
10	25	F Type Flange	50A	AT25M-10-30-HF/F16	KY5072 <input type="checkbox"/> 0	AT25M-10-30-HF/F16E	KY7072 <input type="checkbox"/> 0
		D Type Flange		/D16	KY5073 <input type="checkbox"/> 0	/D16E	KY7073 <input type="checkbox"/> 0
F Type Flange		AT25M-20-30-HF/F16		KY5074 <input type="checkbox"/> 0	AT25M-20-30-HF/F16E	KY7074 <input type="checkbox"/> 0	
D Type Flange		/D16		KY5075 <input type="checkbox"/> 0	/D16E	KY7075 <input type="checkbox"/> 0	
20	23	F Type Flange		AT25M-30-30-HF/F16	KY5076 <input type="checkbox"/> 0	AT25M-30-30-HF/F16E	KY7076 <input type="checkbox"/> 0
		D Type Flange		/D16	KY5077 <input type="checkbox"/> 0	/D16E	KY7077 <input type="checkbox"/> 0
30	25	F Type Flange		AT23M-40-30-HF/F16	KY5078 <input type="checkbox"/> 0	AT23M-40-30-HF/F16E	KY7078 <input type="checkbox"/> 0
		D Type Flange		/D16	KY5079 <input type="checkbox"/> 0	/D16E	KY7079 <input type="checkbox"/> 0
40	23	F Type Flange	AT25M-50-30-HF/F16	KY5080 <input type="checkbox"/> 0	AT25M-50-30-HF/F16E	KY7080 <input type="checkbox"/> 0	
		D Type Flange	/D16	KY5081 <input type="checkbox"/> 0	/D16E	KY7081 <input type="checkbox"/> 0	

Please designate Model Code and Product Code in your order.

*Select E (CE Mark), U (ASME U-Stamp) or G (Regulation for Boiler and Pressure Vessel Manufacture Licensing) with regard to of the Product Code. Note: CE Mark models are not available for any models with a TR cap.

AT series Middle High Flow (MH) Type

- Rubber Material: Symbol 30 (NBR Standard Nitrile Rubber)
- Applicable Fluid: Common Mineral Hydraulic Oil

Nominal Volume ℓ	Maximum Working Pressure MPa	Joint for Fluid Port Connecting	Size	Without TR CAP		With TR CAP (Note)	
				Model Code	Product Code *	Model Code	Product Code *
10	25	F Type Flange	65A	AT25M-10-30-MH/F20	KY5082 <input type="checkbox"/> 0	AT25M-10-30-MH/F20E	KY7082 <input type="checkbox"/> 0
		D Type Flange		/D20	KY5083 <input type="checkbox"/> 0	/D20E	KY7083 <input type="checkbox"/> 0
F Type Flange		AT25M-20-30-MH/F20		KY5084 <input type="checkbox"/> 0	AT25M-20-30-MH/F20E	KY7084 <input type="checkbox"/> 0	
D Type Flange		/D20		KY5085 <input type="checkbox"/> 0	/D20E	KY7085 <input type="checkbox"/> 0	
20	23	F Type Flange		AT25M-30-30-MH/F20	KY5086 <input type="checkbox"/> 0	AT25M-30-30-MH/F20E	KY7086 <input type="checkbox"/> 0
		D Type Flange		/D20	KY5087 <input type="checkbox"/> 0	/D20E	KY7087 <input type="checkbox"/> 0
30	25	F Type Flange		AT23M-40-30-MH/F20	KY5088 <input type="checkbox"/> 0	AT23M-40-30-MH/F20E	KY7088 <input type="checkbox"/> 0
		D Type Flange		/D20	KY5089 <input type="checkbox"/> 0	/D20E	KY7089 <input type="checkbox"/> 0
40	23	F Type Flange		AT25M-50-30-MH/F20	KY5090 <input type="checkbox"/> 0	AT25M-50-30-MH/F20E	KY7090 <input type="checkbox"/> 0
		D Type Flange		/D20	KY5091 <input type="checkbox"/> 0	/D20E	KY7091 <input type="checkbox"/> 0
50	25	F Type Flange		AT23M-80-30-MH/F20	KY5092 <input type="checkbox"/> 0	AT23M-80-30-MH/F20E	KY7092 <input type="checkbox"/> 0
		D Type Flange		/D20	KY5093 <input type="checkbox"/> 0	/D20E	KY7093 <input type="checkbox"/> 0
80	23	F Type Flange		AT23M-120-30-MH/F20	KY5094 <input type="checkbox"/> 0	AT23M-120-30-MH/F20E	KY7094 <input type="checkbox"/> 0
		D Type Flange		/D20	KY5095 <input type="checkbox"/> 0	/D20E	KY7095 <input type="checkbox"/> 0
120	25	F Type Flange		AT23M-150-30-MH/F20	KY5096 <input type="checkbox"/> 0	AT23M-150-30-MH/F20E	KY7096 <input type="checkbox"/> 0
		D Type Flange		/D20	KY5097 <input type="checkbox"/> 0	/D20E	KY7097 <input type="checkbox"/> 0
150	23	F Type Flange	AT23M-160-30-MH/F20	KY5098 <input type="checkbox"/> 0	AT23M-160-30-MH/F20E	KY7098 <input type="checkbox"/> 0	
		D Type Flange	/D20	KY5099 <input type="checkbox"/> 0	/D20E	KY7099 <input type="checkbox"/> 0	

Please designate Model Code and Product Code in your order.

*Select E (CE Mark), U (ASME U-Stamp) or G (Regulation for Boiler and Pressure Vessel Manufacture Licensing) with regard to of the Product Code. Note: CE Mark models are not available for any models with a TR cap.

AT series Ultra High Flow (UH) Type

- Rubber Material: Symbol 30 (NBR Standard Nitrile Rubber)
- Applicable Fluid: Common Mineral Hydraulic Oil

Nominal Volume ℓ	Maximum Working Pressure MPa	Joint for Fluid Port Connecting	Size	Without TR CAP		With TR CAP (Note)	
				Model Code	Product Code *	Model Code	Product Code *
10	23	D Type Flange	80A	AT25M-10-30-UH/D24	KY5100 <input type="checkbox"/> 0	AT25M-10-30-UH/D24E	KY7100 <input type="checkbox"/> 0
20				AT25M-20-30-UH/D24	KY5101 <input type="checkbox"/> 0	AT25M-20-30-UH/D24E	KY7101 <input type="checkbox"/> 0
30				AT25M-30-30-UH/D24	KY5102 <input type="checkbox"/> 0	AT25M-30-30-UH/D24E	KY7102 <input type="checkbox"/> 0
40	21			AT23M-40-30-UH/D24	KY5103 <input type="checkbox"/> 0	AT23M-40-30-UH/D24E	KY7103 <input type="checkbox"/> 0
50	23			AT25M-50-30-UH/D24	KY5104 <input type="checkbox"/> 0	AT25M-50-30-UH/D24E	KY7104 <input type="checkbox"/> 0
80	21			AT23M-80-30-UH/D24	KY5105 <input type="checkbox"/> 0	AT23M-80-30-UH/D24E	KY7105 <input type="checkbox"/> 0
120				AT23M-120-30-UH/D24	KY5106 <input type="checkbox"/> 0	AT23M-120-30-UH/D24E	KY7106 <input type="checkbox"/> 0
150				AT23M-150-30-UH/D24	KY5107 <input type="checkbox"/> 0	AT23M-150-30-UH/D24E	KY7107 <input type="checkbox"/> 0
160				AT23M-160-30-UH/D24	KY5108 <input type="checkbox"/> 0	AT23M-160-30-UH/D24E	KY7108 <input type="checkbox"/> 0

Please designate Model Code and Product Code in your order.

*Select E (CE Mark), U (ASME U-Stamp) or G (Regulation for Boiler and Pressure Vessel Manufacture Licensing) with regard to of the Product Code. Note: CE Mark models are not available for any models with a TR cap.

10. Transfer Barrier Type

The transfer barrier type is used to pump any fluids or gases other than hydraulic fluid.

Model Code Configuration

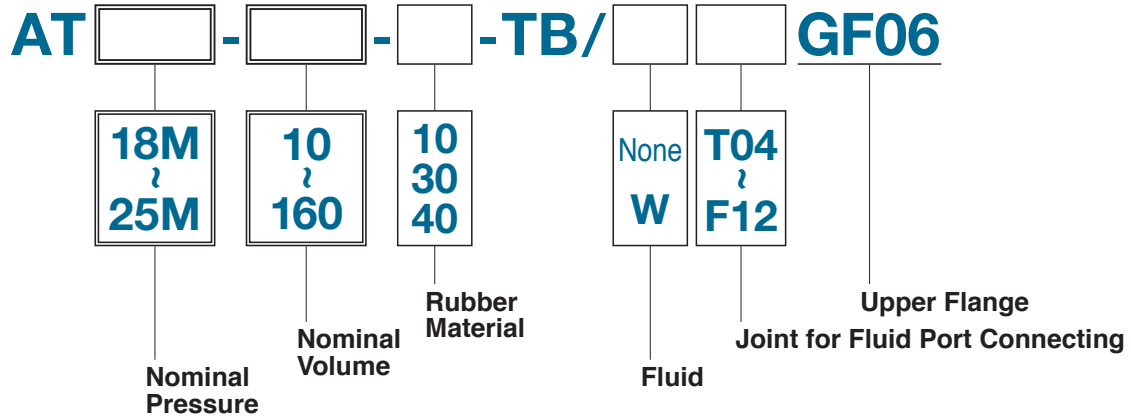

• The AT series is the standard applicable accumulator with an upper flange connection.

AT series 10~60 ℓ

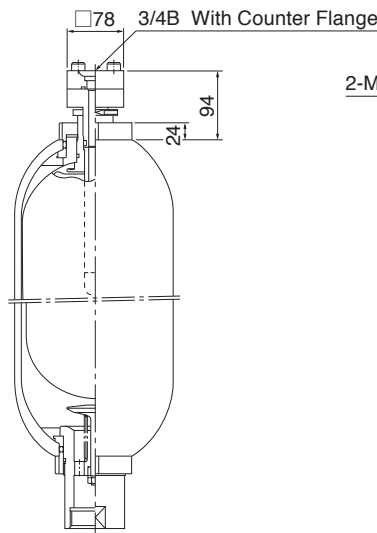

AT series 80~160 ℓ

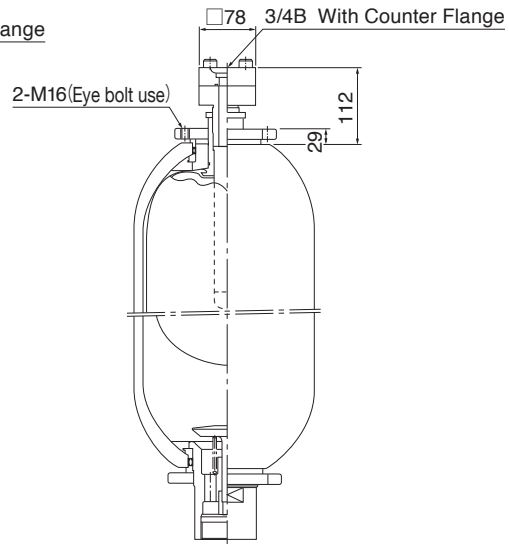

Consult your nearest sales contact to place an order.

11. Piston Type Accumulator

PA series

FOR HIGH PRESSURE AND BIG VOLUME, WE CAN DESIGN FREELY

The Original Seal Makes The Accumulator Have Low Friction And High Sealing Ability.

Model Code Configuration

PA 210-

Nominal Pressure

Nominal Volume

Joint for Fluid Port Connecting

None
E^(Note)

Specifications Required by the Gas Side

Material of O-rings

Symbol	Material	Fluid	Temperature	Note
30	NBR (Standard Nitrile Rubber)	Common Mineral Hydraulic Oil	-20~100°C	Standard Material
10	NBR (Nitrile Rubber for Low Temperature Use)	Common Mineral Hydraulic Oil	-40~80°C	Material For Low Temp.
70	FKM (Fluororubber)	Common Mineral Hydraulic Oil Phosphoric Ester Hydraulic Oil	-15~150°C	For High Temp., For Chemicals ^(Note)

(Note) If the maximum working temperature exceeds 100°C, then ensure to consult your nearest sales contact as it will require a special design.

(Note) In case of ambient temperature always exceeding 80°C, TR Cap cannot be used.

Type A

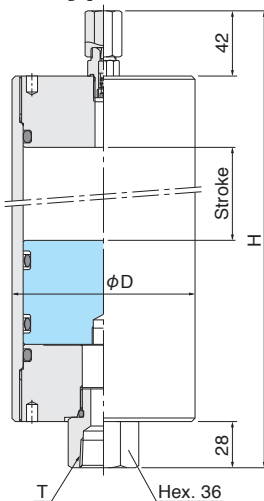

Type B

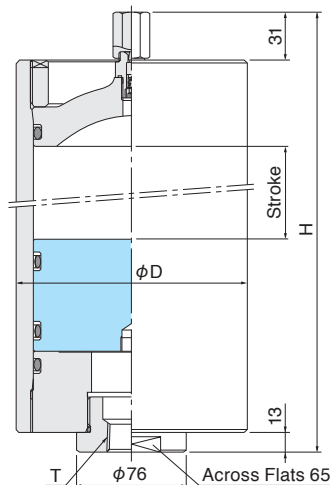

Type C

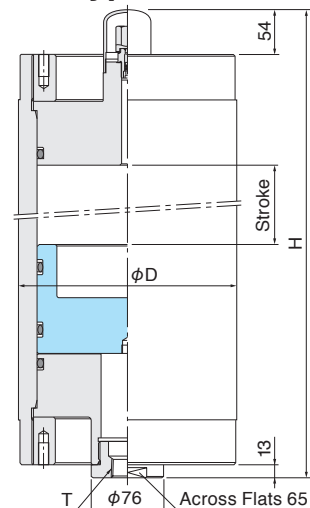

The following list is of representative sizes. Please consult your nearest sales contact for any other size.

Type	Inner mm	Standard Product Model	Maximum Working Pressure MPa	Gas Volume ℓ	Mass kg	Dimension mm		Thread T	Stroke mm	Maximum Discharge Flow Rate ℓ/min	Product Code	
						H	D				Without TR CAP	With TR CAP
A	100	PA210- 1-30/T06(E)	20.6	1	13	340(357)	114.3	Rc 3/4	128	220 [700]	KW6936 A4	KW6924 A4
		PA210- 2-30/T06(E)		2	16	468(485)			256		KW6937 A4	KW6925 A4
		PA210- 3-30/T06(E)		3	18	595(612)			383		KW6938 A4	KW6926 A4
		PA210- 4-30/T06(E)		4	20	722(739)			510		KW6939 A4	KW6927 A4
B	140	PA210- 4-30/T08(E)	20.6	4	37	489(507)	165.2	Rc 1	254	450 [1400]	KW6940 A4	KW6928 A4
		PA210- 5-30/T08(E)		5	40	554(572)			319		KW6941 A4	KW6929 A4
		PA210-10-30/T08(E)		10	55	879(897)			644		KW6942 A4	KW6930 A4
C	200	PA210-10-30/T08(E)	20.6	10	128	703(718)	241.8	Rc 1	283	450 [2800]	KW6943 A4	KW6931 A4
		PA210-20-30/T08(E)		20	166	1032(1047)			612		KW6944 A4	KW6932 A4
		PA210-30-30/T08(E)		30	202	1348(1363)			928		KW6945 A4	KW6933 A4
		PA210-40-30/T08(E)		40	238	1660(1675)			1240		KW6946 A4	KW6934 A4
		PA210-50-30/T08(E)		50	275	1991(2006)			1571		KW6947 A4	KW6935 A4

Notes: () with TR Cap

Please designate Model Code and Product Code in your order.

Consult your nearest sales contact to place an order for a fixing band.

Note: Values in the [] represent the maximum discharge flow obtained by changing the bore of the joint for fluid port connecting.

12. Expansion Tank

ET series

LOW-PRESSURE ACCUMULATOR FOR WATER

Accumulator for Potable Water that is of Excellent Chlorine Resistance

Model Code Configuration

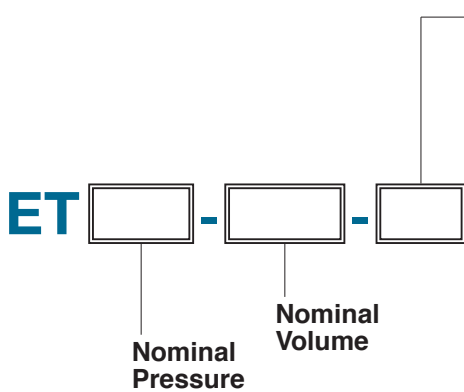

Rubber Material

Symbol	Material	Fluid	Temperature
52 For Type A (0.5, 1, 2 ℓ)	CM (Chlorinated Polyethylene)	Potable Water, Industrial Water	-10~85°C
50 For Type B(10,20ℓ) For Type C(20ℓ)			

- Note that Type A (0.5, 1 and 2 ℓ) cannot be refilled with gas. Use at 40 °C or less is recommended. Also, the product is delivered filled with nitrogen gas at the factory. Please ensure to let us know the desired gas pressure (___MPa at ___°C) when placing an order. Pressure can be specified from 0.04 MPa to 0.3 MPa in 0.01 MPa increments.
- Type B (10 and 20 ℓ) and Type C (20 ℓ) can be refilled with gas.

Type A

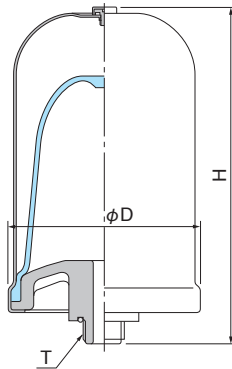

Type B

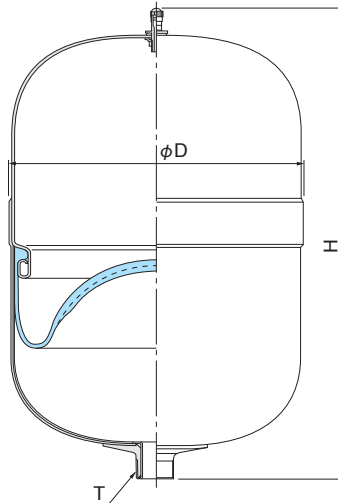

Type C

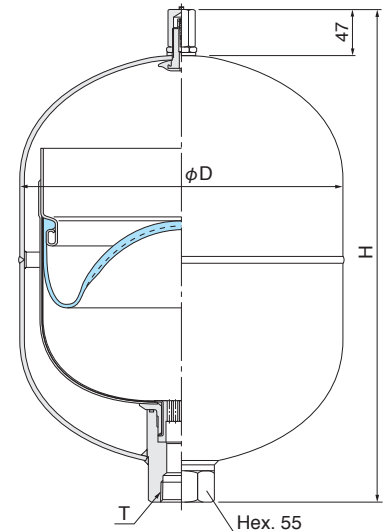

Type	Model Code	Maximum Working Pressure MPa	Gas Volume ℓ	Mass kg	Dimension mm		Thread T	Maximum Discharge Flow Rate ℓ/min	Product Code
					H	D			
A	ET4.5-0.5-52	0.45	0.6	0.6	134	112	G1/2	30	KE7522 J4~KE7523 S4
	ET4.5-1-52		1.0	0.8	201	112	G1/2		KE7524 J4~KE7525 S4
	ET5-2-52	0.5	2.0	1.4	219	143	G3/4		KE7526 J4~KE7527 S4
B	ET8.5-10-50	0.85	11.5	4.5	375	233	R3/4	90	KE5671 D4
	ET8.5-20-50		18.6	6.0	440	273	R3/4		KE5672 E4
C	ET20-20-50	2.0	20	20	472	309	Rc1 1/4	90	KE6957 E4

Please designate Model Code and Product Code in your order.

Type A has different Product Codes for the differing filled gas pressures. Consult your nearest sales contact for more details.

13. Joint for Fluid Port Connecting

In order to make the accumulator be easily connected, there has prepared bushing and flange of various sizes. Please place order with accumulator.

Selecting of bushing and flange should be in accord with joint mount thread of accumulator fluid port.

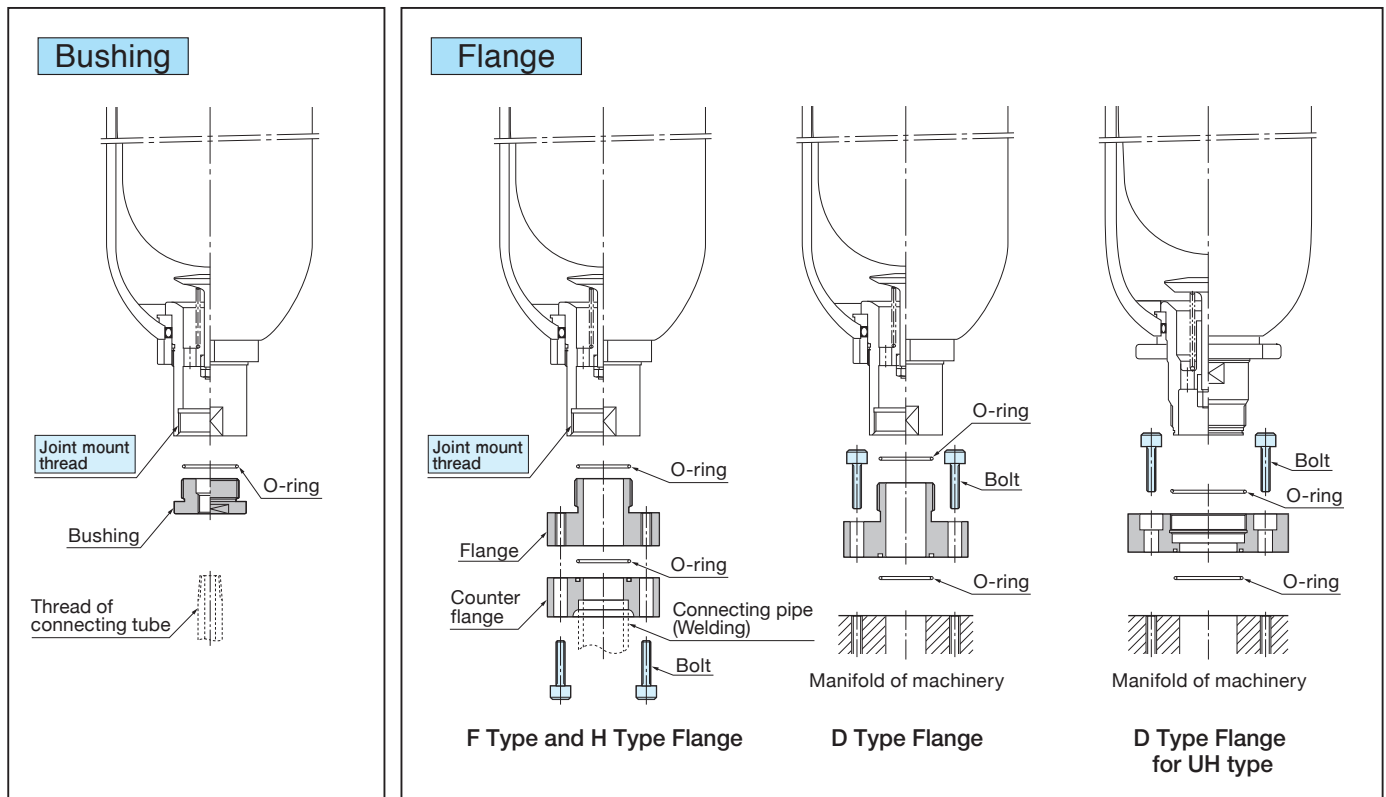

① Bushing (With O-ring and Backup Ring)

Symbol	Thread Size of Connecting Tube	Applicable Accumulator (Joint Mount Thread)	Figure	Dimension mm			O-ring Applied on "F" [Common Mineral Hydraulic Oils]	Purchase separately		
				A	B	C		Model Code	Product Code	
T03	R3/8	PA (Type A)		32	8	Rc3/8	JIS B2401 1B P22	PAL101-049	EB1701 Z1	
T04	R1/2	AL1, 2.4 ℓ (G3/4)		36	30	Rc1/2		AS568-222 Former AN6227#27 (NBR90°)	PAL101-050	EB1702 Z1
T06	R3/4					Rc3/4			PAL101-051	EB1703 Z1
T04	R1/2	AL4, 5 ℓ (G1 1/4)			50	10	Rc1/2	AS568-222 Former AN6227#27 (NBR90°)	PAL101-052	EB1704 Z1
T06	R3/4						Rc3/4		PAL101-053	EB1705 Z1
T08	R 1						Rc 1		PAL101-054	EB1706 Z1
T04	R1/2	PA (Types B,C) AT10~60 ℓ (G2)		76	13	Rc1/2	JIS B2401 1B G55	PAT101-028	EB1707 Z1	
T06	R3/4					Rc3/4		PAT101-029	EB1708 Z1	
T08	R 1					Rc 1		PAT101-030	EB1709 Z1	
T10	R1 1/4					Rc 1 1/4		PAT101-031	EB1710 Z1	
T06	R3/4	AT-HF, MH AT80~160 ℓ (G3)		108	40	Rc3/4	AS568-336 Former AN6227#39 (NBR70°)	PAT101-032	EB1711 Z1	
T08	R 1					Rc 1		PAT101-033	EB1712 Z1	
T10	R1 1/4					Rc 1 1/4		PAT101-034	EB1713 Z1	
T12	R1 1/2					Rc 1 1/2		PAT101-035	EB1714 Z1	

When purchasing without accumulator ● Please designate Model Code and Product Code. Material: Steel (Standard Material)
● Stainless steel is also available.

② Flange

F-Type Flange Set (With Counter Flange, Bolts, O-rings, Backup Ring)

Maximum Working Pressure: 21 MPa

Symbol	Connecting Pipe Bore Size	Counter Flange JIS B2291	Applicable Accumulator (Joint Mount Thread)	Figure (Applied O-ring: For Common Mineral Hydraulic Oils)	Dimension mm					Purchase of Flange Set		
					A	B	C	D	E	Model Code	Product Code	
F04	15A (1/2B)	SSA15	AL1, 2.4 ℓ (G3/4)		75	38	16	36	M10	PAL101-056	EB1715 Z1	
F06	20A (3/4B)	SSA20					20	40		PAL101-057	EB1716 Z1	
F06	20A (3/4B)	SSA20	AL4, 5 ℓ (G1 1/4)		75	38	20	40	M10	PAL101-058	EB1717 Z1	
F08	25A (1B)	SSA25					108	43	25	48	M12	PAL101-059
F06	20A (3/4B)	SSA20	AT10~60 ℓ AT-SH type (G2)		80	38	20	40	M10	PAT101-036	EB1719 Z1	
F08	25A (1B)	SSA25					108	25	48	M12	PAT101-037	EB1720 Z1
F10	32A (1 1/4B)	SSA32									30	56
F12	40A (1 1/2B)	SSA40					128	40	37	65	M16	PAT101-039
F12	40A (1 1/2B)	SSA40	AT-HF, MH AT80~160 ℓ (G3)		128	36	37.5	65	M16	PAT101-101	EB1742 Z1	
F16	50A (2B)	SSA50					138	47.5		73	PAT101-102	EB1743 Z1
F20	65A (2 1/2B)	SSA65			178	45	60	92	M20	PAT101-103	EB1744 Z1	
F24	80A (3B)	SSA80					198	71	103	M22	PAT101-104	EB1745 Z1

When purchasing without accumulator ● Please designate Model Code and Product Code. Material: Steel (Standard Material)
● Stainless steel is also available.

[Information] JIS B 2291 Counter Flange Dimension

Symbol	Nominal Bore Size	Figure	Dimension mm							O-ring Applied on "H" JIS B2401 [Common Mineral Hydraulic Oils]
			A	B	C	D	E	F	G	
F04	SSA15		54	22	16	36	11	22.2	11	1B G25
F06	SSA20		58	22	20	40	11	27.7	12	1B G30
F08	SSA25		68	28	25	48	13	34.5	14	1B G35
F10	SSA32		76	28	31.5	56	13	43.2	16	1B G40
F12	SSA40		92	36	37.5	65	18	49.1	18	1B G50
F16	SSA50		100	36	47.5	73	18	61.1	20	1B G60
F20	SSA65		128	45	60	92	22	77.1	22	1B G75
F24	SSA80		140	45	71	103	24	90	25	1B G85

H-Type Flange Set (With Counter Flange, Bolts, O-rings, Backup Ring)

Maximum Working Pressure: 35 MPa

Symbol	Connecting Pipe Bore Size	Applicable Accumulator (Joint Mount Thread)	Figure (Applied O-ring: For Common Mineral Hydraulic Oils)	Dimension mm					Purchase of Flange Set	
				A	B	C	D	E	Model Code	Product Code
H04	15A (1/2B)	AL1, 2.4 ℓ (G3/4)		86	42	16	44	M12	PAL101-060	EB1726 Z1
H06	20A (3/4B)			93	42	20	49	M12	PAL101-061	EB1727 Z1
H06	20A (3/4B)	AL4, 5 ℓ (G1 1/4)		93	42	20	49	M12	PAL101-062	EB1728 Z1
H08	25A (1B)			108	42	25	57	M16	PAL101-063	EB1729 Z1
H06	20A (3/4B)	AT10~60 ℓ AT-SH (G2)		93	42	20	49	M12	PAT101-043	EB1730 Z1
H08	25A (1B)			108	42	25	57	M16	PAT101-044	EB1731 Z1
H10	32A (1 1/4B)			118	42	30	65	M16	PAT101-045	EB1732 Z1
H12	40A (1 1/2B)			138	44	37	75	M20	PAT101-046	EB1733 Z1
H16	50A (2B)	AT-HF, MH AT80~160 ℓ (G3)		158	45	47.5	88	M20	PAT101-116	EB1761 Z1
H20	65A (2 1/2B)			198	55	60	110	M24	PAT101-117	EB1762 Z1
H24	80A (3B)			228	55	71	124	M30	PAT101-118	EB1763 Z1

When purchasing without accumulator ● Please designate Model Code and Product Code. Material: Steel (Standard Material)
● Stainless steel is also available.

Counter Flange Dimension

Symbol	Connecting Pipe Bore Size	Figure	Dimension mm							O-ring Applied on "H" JIS B2401 [Common Mineral Hydraulic Oils]
			A	B	C	D	E	F	G	
H04	15A(1/2B)		74	25	16	44	14	22.2	10	1B G25
H06	20A(3/4B)		78	25	20	49	14	27.7	17	1B G30
H08	25A(1B)		90	32	25	57	18	34.5	19	1B G35
H10	32A(1 1/4B)		100	32	30	65	18	43.2	20	1B G40
H12	40A(1 1/2B)		118	40	38	75	22	49.1	23	1B G50
H16	50A(2B)		134	45	47.5	88	22	61.1	25	1B G60
H20	65A(2 1/2B)		170	55	60	110	26	77.1	28	1B G75
H24	80A(3B)		186	55	71	124	32	90	31	1B G85

D-Type Flange Set, Manifold Direct Connecting (With Bolts, O-rings, Backup Ring)

Maximum Working Pressure: 25 MPa

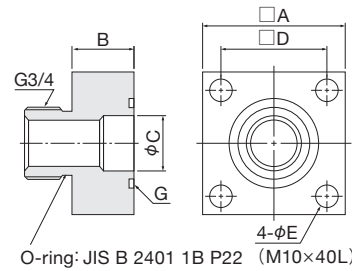
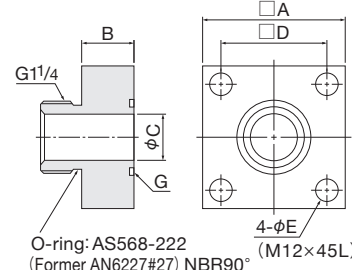
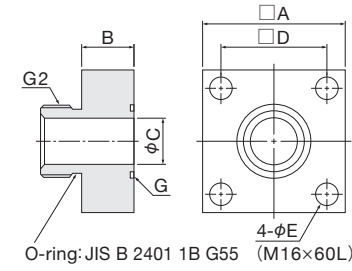
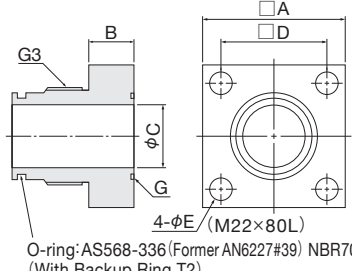
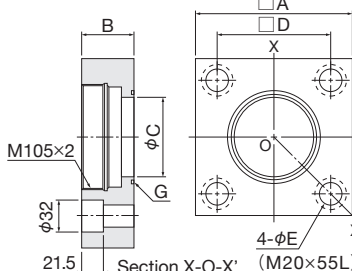
Symbol	Connecting Pipe Bore Size	Applicable Accumulator (Joint Mount Thread)	Figure (Applied O-ring: For Common Mineral Hydraulic Oils)	Dimension mm					O-ring Applied on "G" JIS B2401 [Common Mineral Hydraulic Oils]	Purchase of Flange Set	
				A	B	C	D	E		Model Code	Product Code
D04	15A (1/2B)	AL1, 2.4 ℓ (G3/4)		68	25	16	48	11	1B G25	PAL101-112	EB1746 Z1
D06	20A (3/4B)									20	1B G30
D06	20A (3/4B)	AL4, 5 ℓ (G1 1/4)		76	28	20	56	13	1B G30	PAL101-114	EB1748 Z1
D08	25A (1B)									25	1B G35
D10	32A (1 1/4B)	AT10~60 ℓ AT-SH type (G2)		100	36	32	73	18	1B G40	PAT101-107	EB1752 Z1
D12	40A (1 1/2B)									38	1B G50
D16	50A (2B)	AT-HF, MH AT80~160ℓ (G3)		140	45	48	103	24	1B G60	PAT101-110	EB1755 Z1
D20	65A (2 1/2B)									60	1B G75
D16	50A (2B)	AT-UH (M105x2 (male thread))		140	45	48	103	22	1B G60	PAT101-113	EB1759 Z1
D24	80A (3B)									155	50

When purchasing without accumulator ● Please designate Model Code and Product Code. Material: Steel (Standard Material)
● Stainless steel is also available.

14. Accumulator Stop Valve (Maximum Working Pressure: 21 MPa)

Accumulator stop valve is the multiple valve which consists of a main valve and a drain valve. Fluid pressure can be relieved by shutting the main valve and opening the drain valve, which facilitates the checking of the filled gas pressure and the replacement of the accumulator and the bladder.

Model Code Configuration

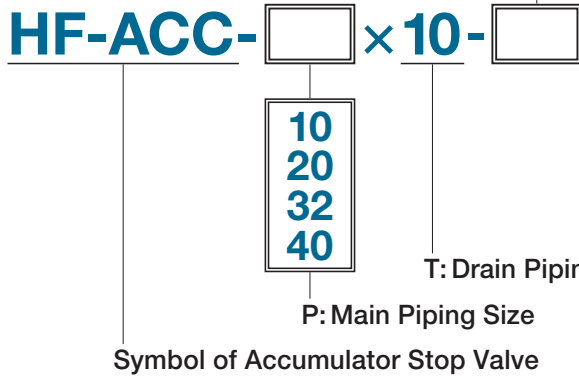

Accumulator size

Symbol	Accumulator Size
20	AL1, 2.4 ℓ
32	AL4, 5 ℓ
50	AT10, 20, 30, 40, 50, 60 ℓ, All SH type
80	AT80, 120, 150, 160 ℓ, HF, MH

JIS Symbol Mark

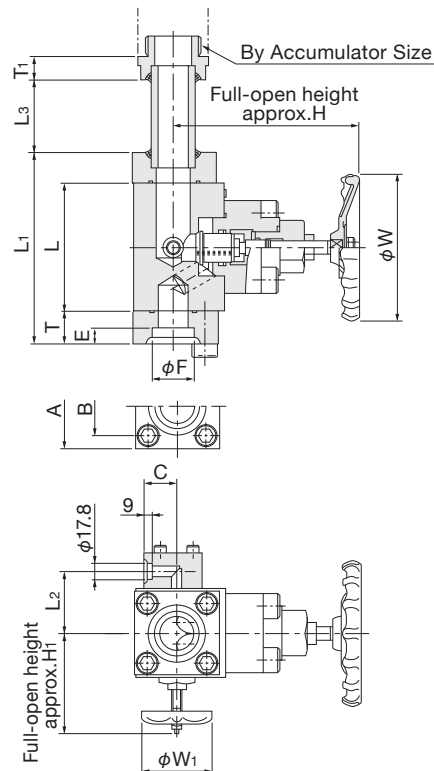
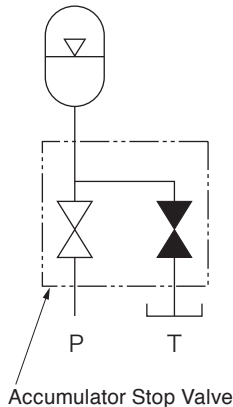

Model Code	Main Piping Size P	Drain Piping Size T	Dimension mm														Mass kg	
			L	L ₁	L ₂	L ₃	T	T ₁	Flange Dimension					H	H ₁	W		W ₁
									A	B	C	E	F					
HF-ACC-10×10-□	10A(3/8B)	3/8B (10A)	100	142	47.5	50	21	25	58	40	33	9	17.8	141	96	120	80	6.0
HF-ACC-20×10-□	20A(3/4B)		100	142	47.5	50	21	25	58	40	33	12	27.7	141	96	120	80	6.2
HF-ACC-32×10-□	32A(1 ¹ / ₄ B)		110	164	60.5	60	27	25	76	56	33	16	43.2	202	109	180	80	13.5
HF-ACC-40×10-□	40A(1 ¹ / ₂ B)		140	210	69.0	80	35	25	92	65	36	18	49.1	209	114	160	80	22.5

When purchasing without accumulator ● Please designate Accumulator size and main piping size.

● At occasion of applying other hydraulic fluid than mineral oils, please inform applied fluid.

Consult your nearest sales contact if you need the product whose maximum working pressure is over 21MPa.

15. TR Cap (Fusible-plug Safety Valve)

TR Cap is a safety valve, which operates at occasion of unusual high ambient temperature, such as a fire. NOK recommends applying TR Cap to ensure safety.

Please order with Accumulator.

It can be mounted on an Accumulator in operation without discharging nitrogen gas.

Model Code Configuration

Please add "E" at the end of Accumulator Model Code, such as below.

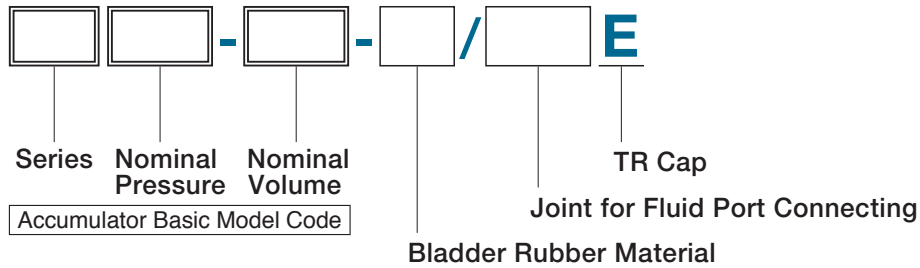

Structure

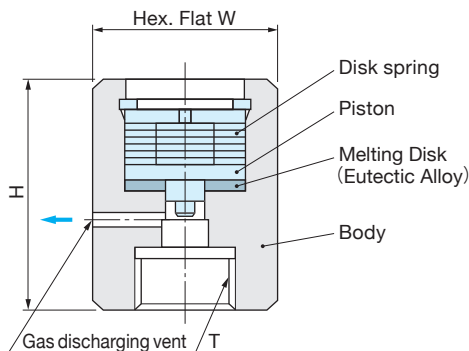

To purchase TR Cap separately, please designate Model Code and Product Code.

Model Code	Dimension mm			Product Code	Note
	H	W	T		
TR3-150	30	22	5/8-18UNF	EB 3710 S0	Standard

Operating Description

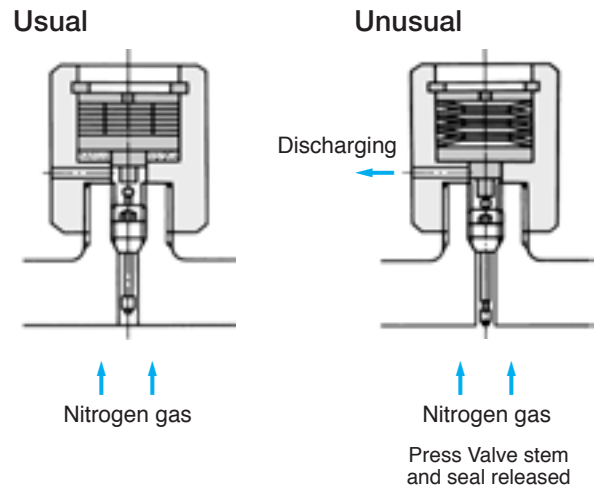

1. External heat of temperature exceeding 150°C melts Melting Disk. Melting Disk melts due to heating.
2. Due to melting of Melting Disk, the piston is pressed by disk springs to move downward.
3. The piston presses the valve stem of the gas valve and releases the seal.

Thus, nitrogen gas in Accumulator sealed by gas valve is discharged to atmosphere through gas discharging vent.

In case of ambient temperature always exceeding 80°C, TR Cap cannot be used.

16. Gas Control Valve

The gas control valve not only facilitates the filling of the gas and the gas pressure to be checked but also incorporates a safety valve function.

Two types of safety valve are available: fuse metal or spring type.

Either valve can be selected when ordering an accumulator.

Model Code Configuration

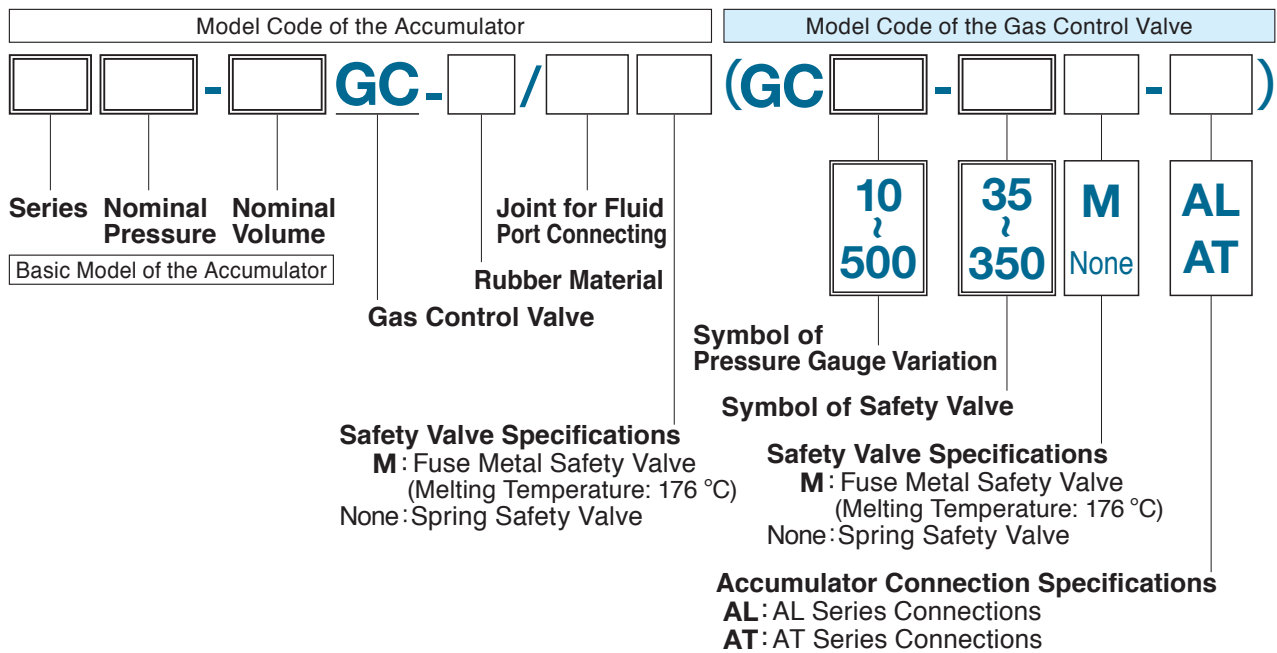

Ensure the "Maximum working pressure of the accumulator ≤ Maximum working pressure of the safety valve" when selecting a safety valve.

Model Code		Pressure Gauge			Fuse Metal Safety Valve			Spring Safety Valve		
Safety Valve Specifications		Symbol of Pressure Gauge	Scale range of Pressure Gauge	Outside Diameter φ mm	Symbol of Safety Valve	Maximum Working Pressure MPa	Maximum Pressure of Seal MPa	Symbol of Safety Valve	Maximum Working Pressure MPa	Set Safety Valve Pressure MPa
Fuse Metal Safety Valve	Spring Safety Valve									
GC 10- 35M-□	GC 10- 35-□	10	0~1.0	60	35	3.43	5.15	35	3.43	3.82
GC 35- 35M-□	GC 35- 35-□									
GC 70- 35M-□	GC 70- 35-□									
GC 70- 70M-□	GC 70- 70-□	70	0~7.0	60	70	6.86	10.3	70	6.86	7.55
GC160- 70M-□	GC160- 70-□									
GC160-150M-□	GC160-150-□	160	0~16	60	150	14.7	22.1	150	14.7	16.2
GC250-150M-□	GC250-150-□									
GC250-175M-□	GC250-175-□									
GC250-210M-□	GC250-210-□	250	0~25	60	175	17.2	25.7	175	17.2	18.9
GC250-250M-□	GC250-250-□									
GC350-250M-□	GC350-250-□									
GC350-300M-□	GC350-300-□	350	0~35	75	210	20.6	30.9	210	20.6	22.6
GC500-300M-□	GC500-300-□									
GC500-350M-□	GC500-350-□									
		500	0~50	75	250	24.5	36.8	250	24.5	27.0
		500	0~50	75	300	29.4	44.1	300	29.4	32.4
		500	0~50	75	350	34.3	51.5	350	34.3	37.3

- An adapter is required to attach a valve to an existing accumulator. Consult us and ensure to provide the Model Code of the accumulator concerned.
- Consult us if you need the pressure gauge in any other unit than MPa.
- Please designate Model Code in your order.

JIS Symbol Mark

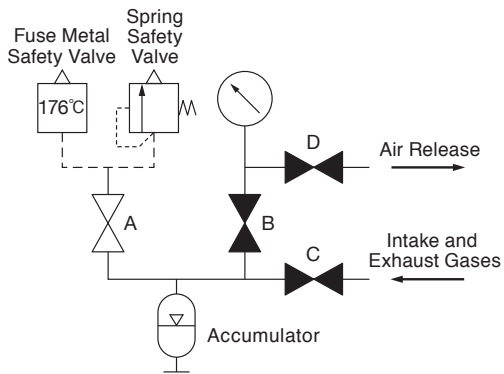

NOK's gas control valve incorporates an independent valve that both protects the pressure gauge and enables any necessary degassing after measuring the pressure.

- A: Stop Valve for Safety Valve Maintenance (Always Open)
- B: Stop Valve for Pressure Gauge Protection (Always Closed)
- C: Coreless Valve for Gas Intake and Exhaust (Always Closed)
(Hose Connection Thread: G1/4)
- D: Pressure Gauge Relief Valve (Always Closed)

Notes 1: Supports pressure measurements at ambient temperatures of between -5 and 40 °C.

2: Use of the always open Valve B can lead to degradation of the accuracy of or damage to the pressure gauge.

For AT series [With Fuse Metal Safety Valve]

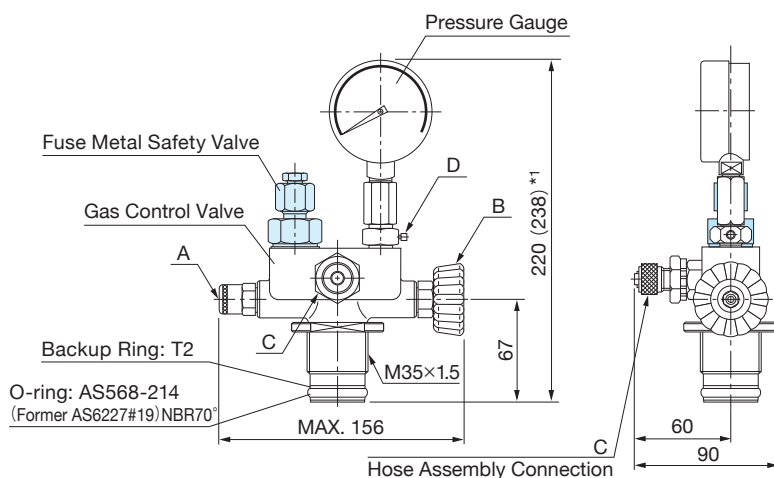

*1: Values in the () provide the dimensions of a $\phi 75$ pressure gauge.

[With Spring Safety Valve]

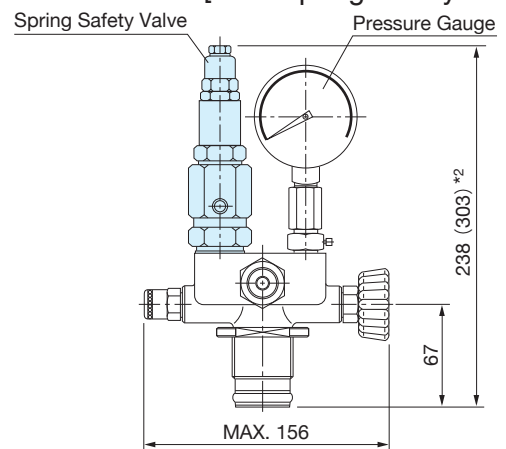

*2: Values in the () provide the dimensions of the GC□-300 and 350.

For AL series [With Fuse Metal Safety Valve]

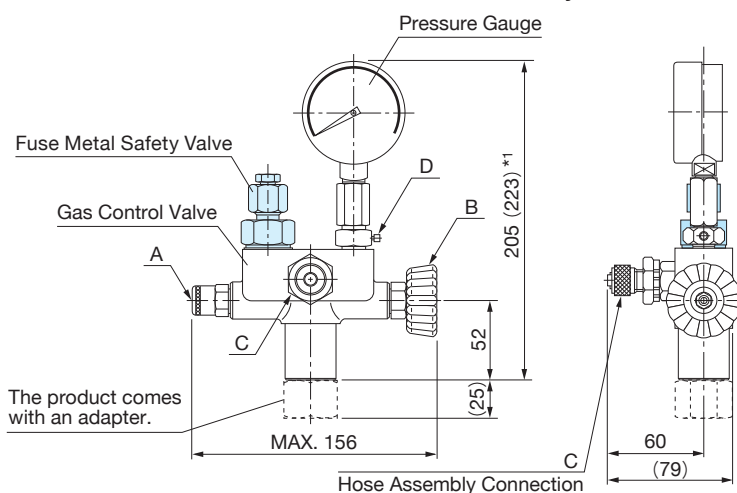

*1: Values in the () provide the dimensions of a $\phi 75$ pressure gauge.

[With Spring Safety Valve]

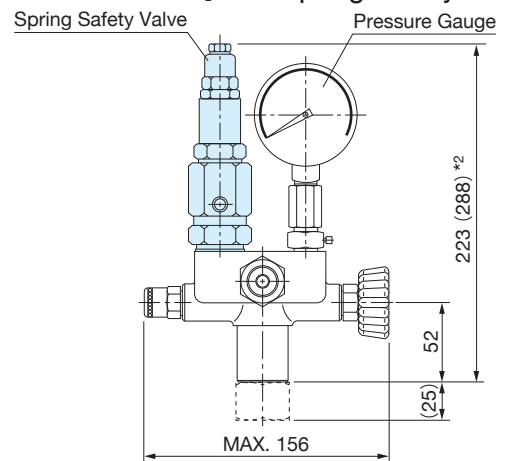

*2: Values in the () provide the dimensions of the GC□-300 and 350.

Structure of Fuse Metal Safety Valve

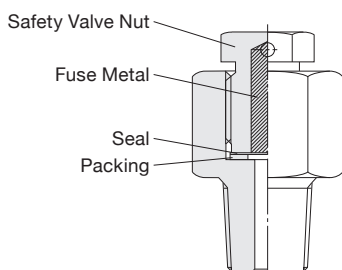

Process Explanation

- ① External heat of temperature exceeding 176 °C melts Fuse Metal.
- ② Once the pressure of the gas increases to the seal burst pressure, the pressure of the seal will burst open and release the air.

17. Gas-filling Tool (Charging Assembly)

NOK Charging Assembly is applied to fill nitrogen gas into Accumulator and check gas pressure. Please purchase Charging Assembly, which is a combination of a Charging Valve and a Hose.

Model Code Configuration

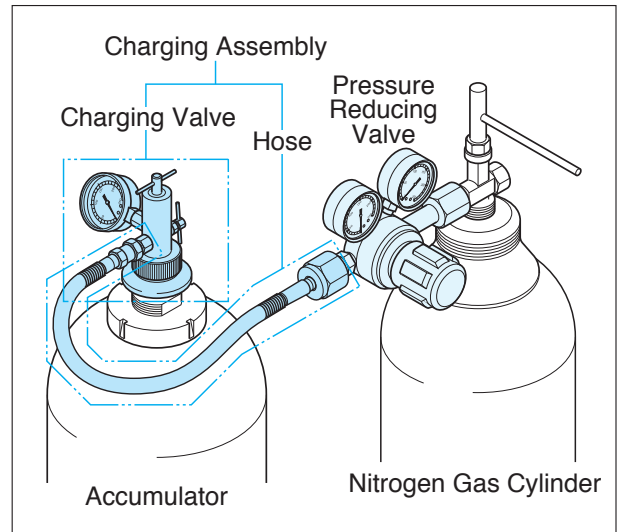
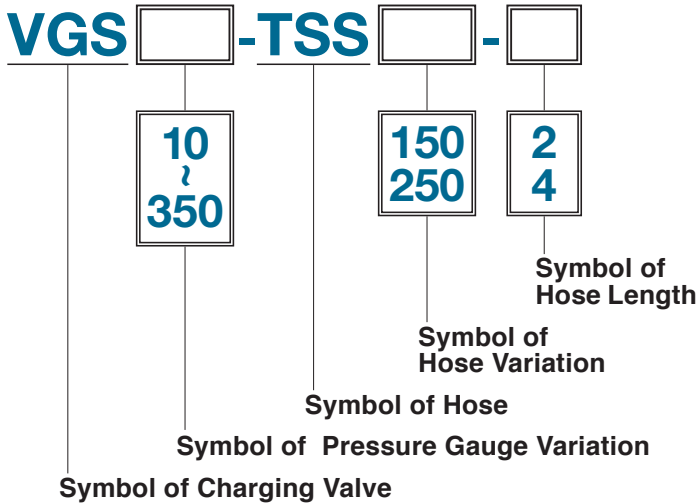

At occasion to fill nitrogen gas into accumulator, please apply a pressure reducing valve between nitrogen gas cylinder and hose, so that the filling operation is engaged safely and easily.

Ensure to remove the charging assembly after filling the equipment with nitrogen gas and having carefully inspected it.

Model Code	VGS (Charging Valve)		TSS (Hose)			Product Code		
	Symbol of Pressure Gauge	Scale Range of Pressure Gauge MPa	Symbol of Hose	Maximum Working Pressure MPa	Hose Length m			
VGS 10-TSS150-2	10	0~1.0	150	14.7	2	EB9017 R0		
VGS 10-TSS150-4					4	EB9018 R0		
VGS 35-TSS150-2	35	0~3.5			2	EB9033 R0		
VGS 35-TSS150-4					4	EB9034 R0		
VGS 70-TSS150-2	70	0~7.0			2	EB9093 R0		
VGS 70-TSS150-4					4	EB9094 R0		
VGS160-TSS150-2	160	0~16			2	EB9045 R0		
VGS160-TSS150-4					4	EB9046 R0		
VGS250-TSS150-2	250	0~25			250	24.5	2	EB9049 R0
VGS250-TSS150-4							4	EB9050 R0
VGS250-TSS250-2			2	EB9053 R0				
VGS250-TSS250-4			4	EB9054 R0				
VGS350-TSS250-2	350	0~35	2	EB9061 R0				
VGS350-TSS250-4			4	EB9062 R0				

- Consult us if you need the pressure gauge in any other unit than MPa.
- Please designate Model Code and Product Code in your order.

■ Charging Valve

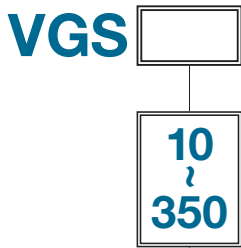

Symbol of Pressure Gauge Variation

A charging valve can be connected to any series accumulator after changing the connection joint. The valve is delivered as shown in Fig. 2.

Applied Accumulator	Connecting Thread	Connecting Joint
AL Series 1~5 l	5/8-18UNF	Remove Joint B and Gasket B, Use Joint A and Gasket A Only (Fig.1)
AT Series		
Minilators		
PA Series		
ET Series (Excluding Type A)	8V1	Combine Joint A and Joint B (Fig. 2)

● No charging valve is required if a gas control valve is already attached.

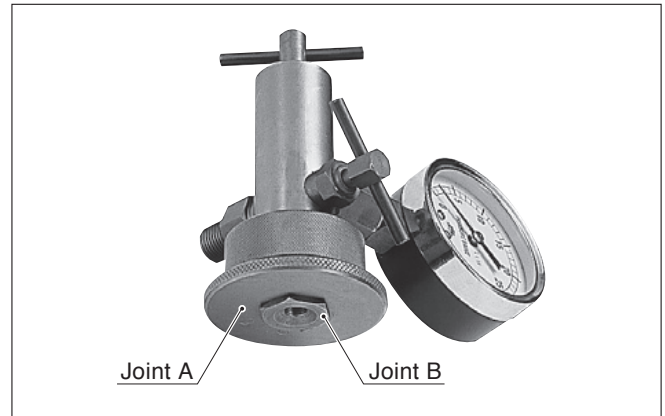

For Thread size 5/8-18UNF

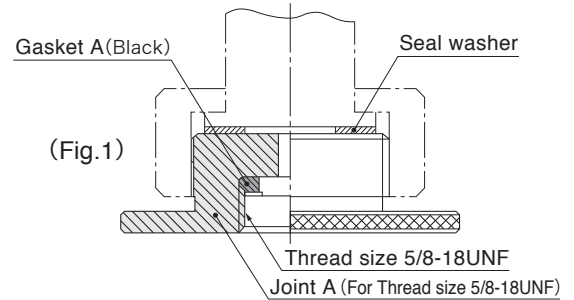

For Thread size 8V1

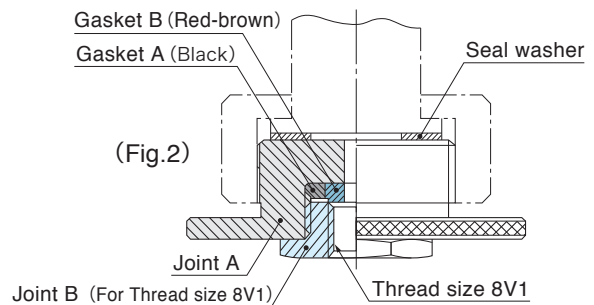

■ Hose

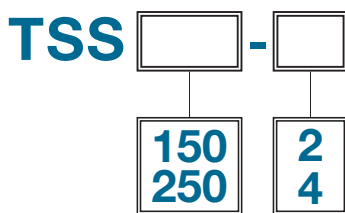

Symbol of Hose Length
Symbol of Hose Variation

The connection thread for the nitrogen gas cylinder follows JIS specifications.

Joint Size of Nitrogen Gas Cylinder	Connection of Hose and Cylinder
W22 Male thread	Hose can be connected directly
W23 Female thread	Apply adaptor (auxiliary)

- Specify the Model Code when purchasing individual VGS and TSS units.
- Consult us if the length of TSS(Hose) exceeds 4 m.
- Reduction valves are available.
- Gaskets, joints, and other parts are also available.

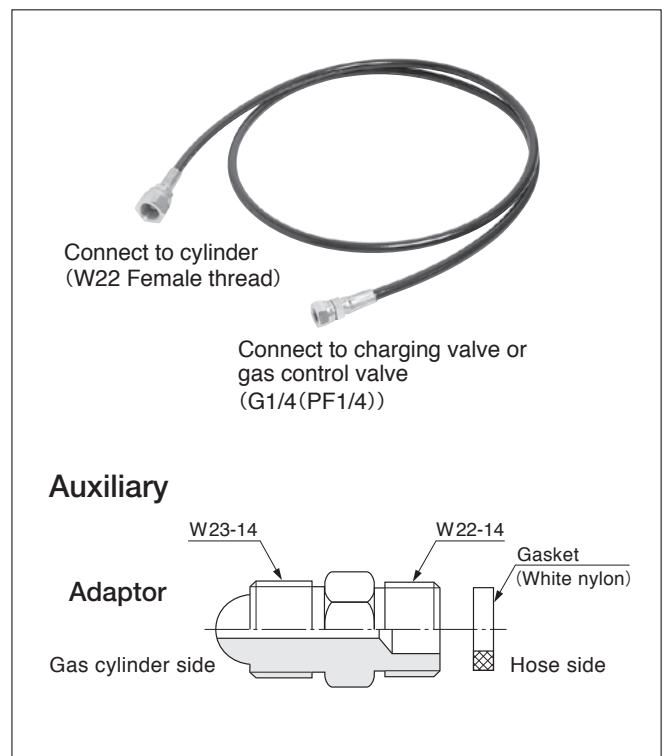

Reduction Valve



Standard Model	Adjustable Pressure Range MPa	Primary Pressure Scale MPa	Secondary Pressure Scale MPa	Product Code
PAT101-063	0~1.6	0~25	0~2.5	EB5490 Z4
PAT101-064	0~11	0~25	0~20	EB5491 Z4

● Please designate Model Code and Product Code in your order.

Gas-Filling Tool Parts (Charging Assembly)

Name	Model Code	Product Code	Details	Figure
Joint Set	PAL101-043	EB4607 Z4	Joint A Joint B Gasket A Gasket B Seal Washers	
Joint Gasket	PAL101-069	EB4608 Z4	Gasket A Gasket B Seal Washers	
Hose Gasket	PAL101-045	EB4609 Z4	Hose Cylinder Connection Side Gasket	
Hose Adapter	PAL101-046	EB4610 Z4	Adaptor	

● Please designate Model Code and Product Code in your order.

18. Fixing Band

Fixing bands for accumulators are available separately.
Ensure to specify the Model Code and Product Code when purchasing.

Fixing bands for accumulator

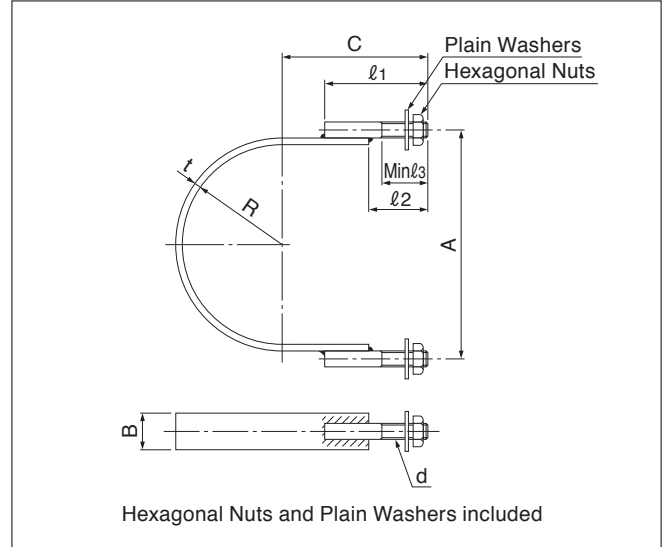
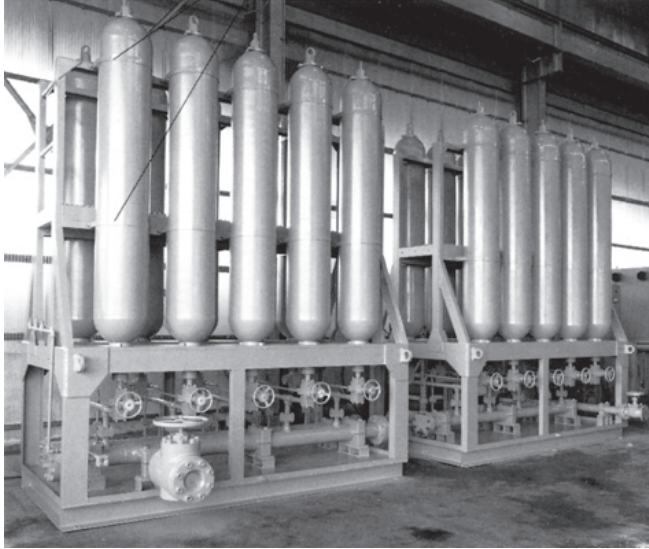

Model Code	Applicable Accumulators	Dimension mm									Mass kg	Product Code
		A	B	C	l ₁	l ₂	l ₃	d	R	t		
PAL101-101	MC70·210-1000, -2000, -3000	135	22	85	60	35	27	M10	58	4.5	0.3	EB6611 Z4
PAL101-102	AL-1, 2,4	141	22	88	60	35	27	M10	61	4.5	0.4	EB6612 Z4
PAL101-103	AL150-4, 5, MC70·210-5000	187	22	115	80	40	31	M10	84	4.5	0.4	EB6613 Z4
PAL101-104	AL300-4, 5	199	22	120	80	40	31	M10	90	4.5	0.45	EB6614 Z4
PAL101-105	AT18M-10, 20, 30, 50 *AT150-10, 20, 30, 50 *AT175-10, 20, 30, 50	249	38	150	100	64	36	M12	114	4.5	0.9	EB6615 Z4
PAL101-106	AT25M-10, 20, 30, 50 *AT250-10, 20, 30, 50	255	38	152	110	60	36	M12	117	4.5	0.95	EB6616 Z4
PAL101-107	AT35M-10, 20, 30 *AT350-10, 20, 30, 50	271	38	161	115	76	36	M12	125	4.5	1.0	EB6617 Z4
PAL101-108	AT23M-30, 40, 50, 60 *AT210-30, 40, 50, 60	297	38	175	125	75	40	M12	138	4.5	1.3	EB6618 Z4
PAL101-110	AT23M-80, 120, 150, 160 *AT210-80, 160 *AT230-120, 150	390	60	225	160	100	45	M20	179	6.0	3.2	EB6620 Z4

- Ensure to fix any accumulator 30 ℓ or more in place using two bands.
- Please designate Model Code and Product Code in your order.
- The products with an asterisk (*) are listed in the previous catalog.

Consult us for any accumulator stand design and manufacture requirements.

19. Assembly and Disassembly Tool

Ensure to use the specialized tools when repairing a bladder type accumulator.

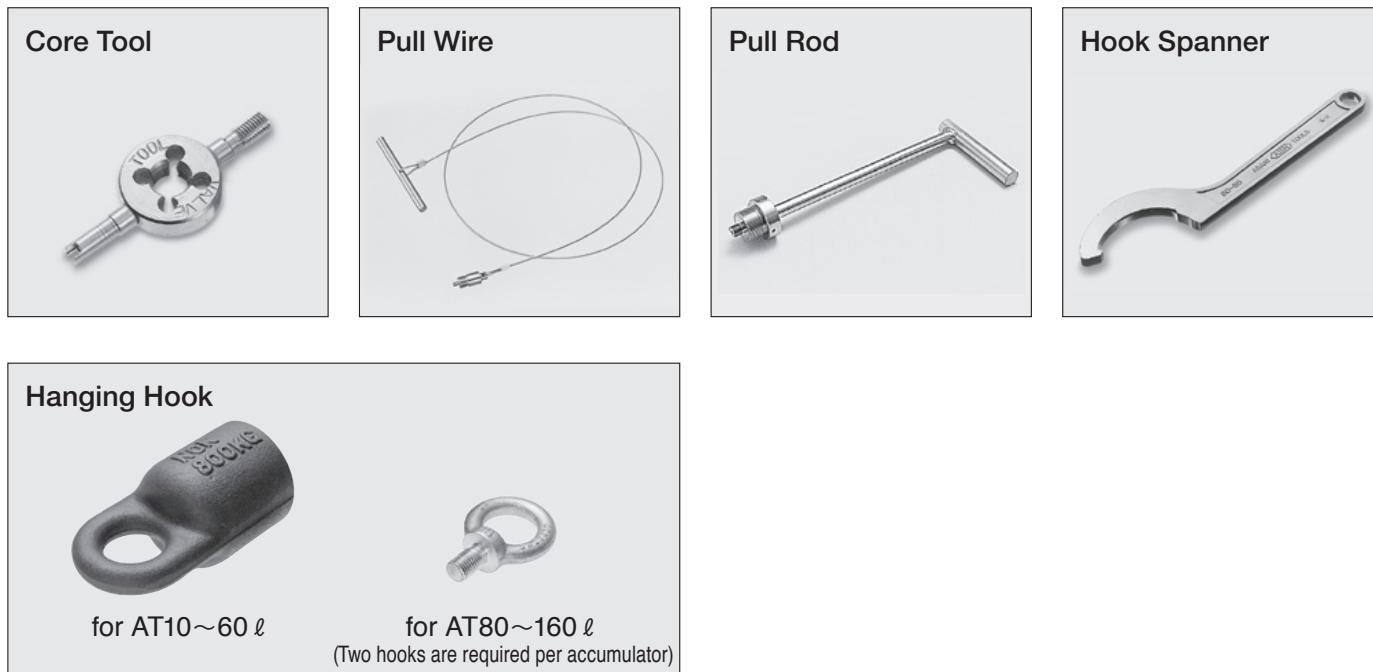

Please consult us separately for the products with the CE Marking as they are different in shape.

Sets of specialized tools are available for assembling and disassembling the AL and AT series. Please designate Model Code and Product Code in your order. (Tools with ○ are available in sets.)

Model Code	Product Code	Applicable Accumulators		Core Tool	Pull Wire	Pull Rod	Hook Spanner	Hanging Hook
TAL150-1	EB1930 T1	AL series	1, 2.4 ℓ	○	○	—	○	—
TAL150-4	EB1931 T1		4, 5 ℓ	○	○	—	○	—
TAT150-10	EB1937 T1	AT series	10, 20, 30, 40, 50, 60 ℓ	—	—	○	○	○
TAT230-120	EB1938 T1		80, 120, 150, 160 ℓ	—	—	○	—	○

Available separately.

Tool Name	Model Code	Product Code	Applicable Accumulators	Purpose
Core Tool	TAL150-1/A	EB1915 T1	All AL series All Minilaor series	Mounting and removing cores
Pull Wire	TAL150-1/B	EB1933 T1	All AL series	Assembling and removing bladders
Pull Rod	TAT150-10/B	EB1935 T1	All AT series	
Hook Spanner	TAL150-1/C	EB1917 T1	AL series 1, 2.4 ℓ	Fastening and loosening lock rings
	TAL150-4/C	EB1918 T1	AL series 4, 5 ℓ	
	TAT150-10/C	EB1919 T1	AT series 10, 20, 30, 40, 50, 60 ℓ	
Hanging Hook	TAT150-10/D	EB1920 T1	AT series 10, 20, 30, 40, 50, 60 ℓ	Hanging an accumulator (Ensure to use two hooks with AT 80, 120, 150 and 160 accumulators)
	TAT230-120/Z	EB1928 T1	AT series 80, 120, 150, 160 ℓ	

● Please designate Model Code and Product Code in your order.

20. Bladder Type Accumulator Replacement Kit

Bladder replacement kits (with sealing materials) for use in repairing bladder type accumulators are available.

The bladder is an important part of a bladder type accumulator but will eventually need to be replaced. Ensure to replace the bladder as early as possible in thereby preventing any unexpected failures.

		Page
1	AL series for 1~5 ℓ	46
2	AT series for 10~60 ℓ and Standard and SH series	48
3	AT series for 10~50 ℓ and HF, MH and UH series	50
4	AT series for 80~160 ℓ and Standard, MH and UH series	52

To place an order:

Specify the Model Code and Product Code of the required bladder replacement kit (includes sealing materials)

If you are unsure exactly which replacement kit to select, ensure to first identify the Model Code and Shell No. of the accumulator to be repaired, then consult your nearest sales contact. We can help select the appropriate one.

The Model Code and Shell No. can be found stamped on the shell shoulder on the gas side.

The basic model code is included in the Model Code.
(The Model Code for high flow, middle-high flow, and ultrahigh flow models is followed by HF.)

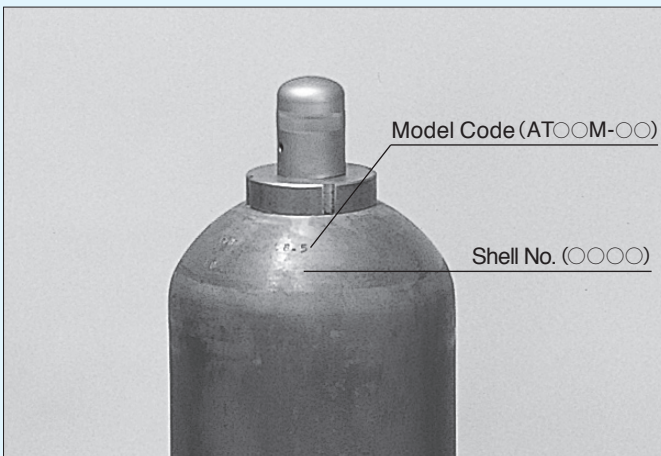

See the nameplate (below) for products with a specified Product Code.



1 AL series Bladder Replacement Kit (Includes Sealing Materials)

Ensure to specify the Model Code and Product Code of the kit when purchasing.

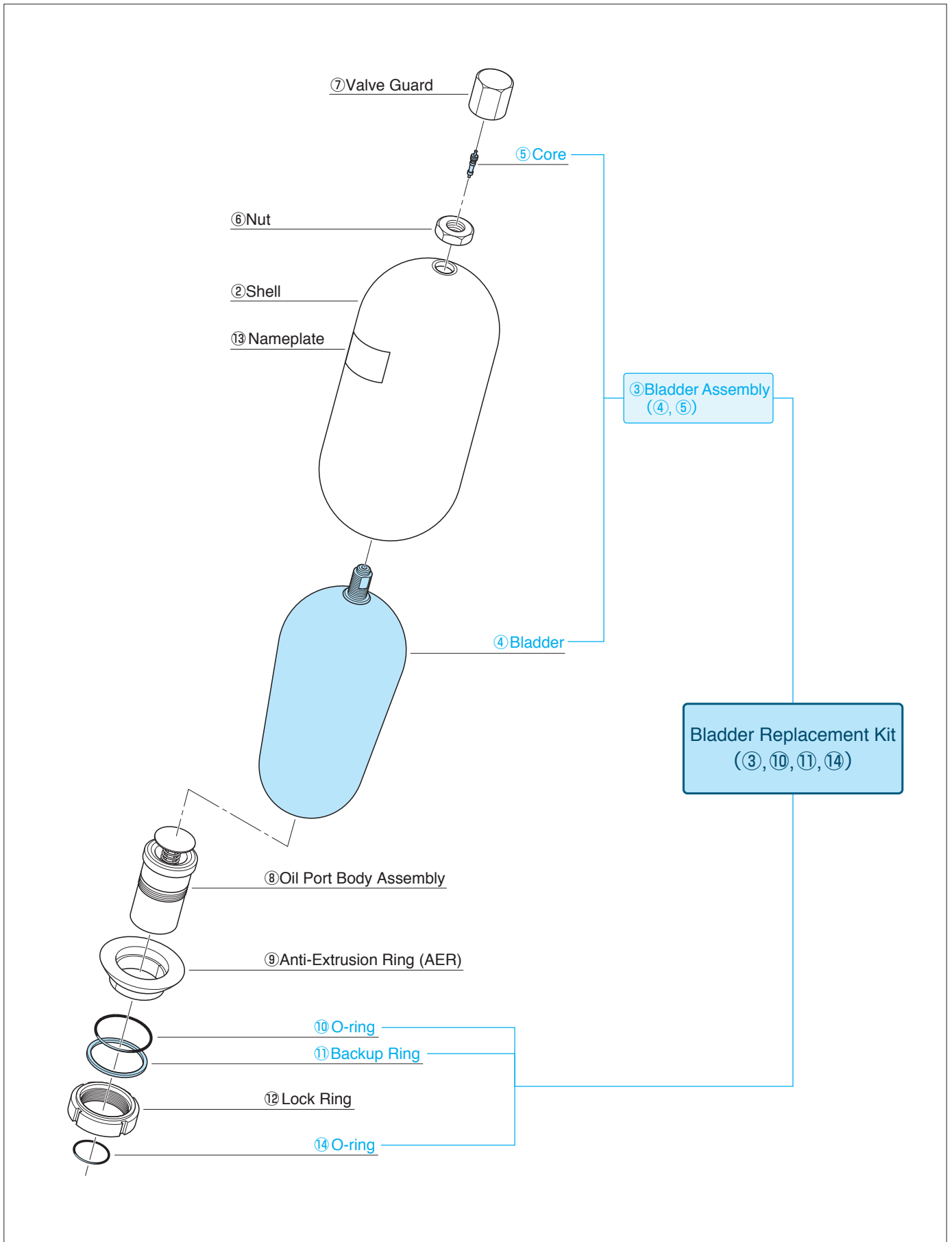

■ For Gas Valve Types (Standard Type)

Volume Category	Applicable Accumulators	Bladder Replacement Kit (Includes Sealing Materials)	
		Model Code	Product Code
1 ℓ	AL150-1-30 AL150-1-30/E	PAL150-1-30	EB1301 B8
	AL300-1-30 AL300-1-30/E		
2.4 ℓ	AL150-2.4-30 AL150-2.4-30/E	PAL150-2.4-30	EB1304 B8
	AL300-2.4-30 AL300-2.4-30/E		
4 ℓ	AL150-4-30 AL150-4-30/E	PAL150-4-30	EB1307 B8
	AL300-4-30 AL300-4-30/E		
5 ℓ	AL150-5-30 AL150-5-30/E	PAL150-5-30	EB1511 B8
	AL300-5-30 AL300-5-30/E		

■ For Gas Control Valve Types

(Include O-rings for the gas control valve connection joints and washers for the locking screw)

Volume Category	Applicable Accumulators	Bladder Replacement Kit (Includes Sealing Materials)	
		Model Code	Product Code
1 ℓ	AL150-1GC-30 AL300-1GC-30	PAL150-1GC-30	EB1595 B1
2.4 ℓ	AL150-2.4GC-30 AL300-2.4GC-30	PAL150-2.4GC-30	EB1598 B1
4 ℓ	AL150-4GC-30 AL300-4GC-30	PAL150-4GC-30	EB1601 B1
5 ℓ	AL150-5GC-30 AL300-5GC-30	PAL150-5GC-30	EB1604 B1

Please designate Model Code and Product Code in your order.

Rubber material replacement kit for the standard nitrile rubber (material mark: -30).
Consult your nearest sales contact if you require any other rubber materials than standard.

2 AT series Bladder Replacement Kit (Includes Sealing Materials)

10 l ~ 60 l (for Standard and SH series)

Ensure to specify the Model Code and Product Code of the kit when purchasing.

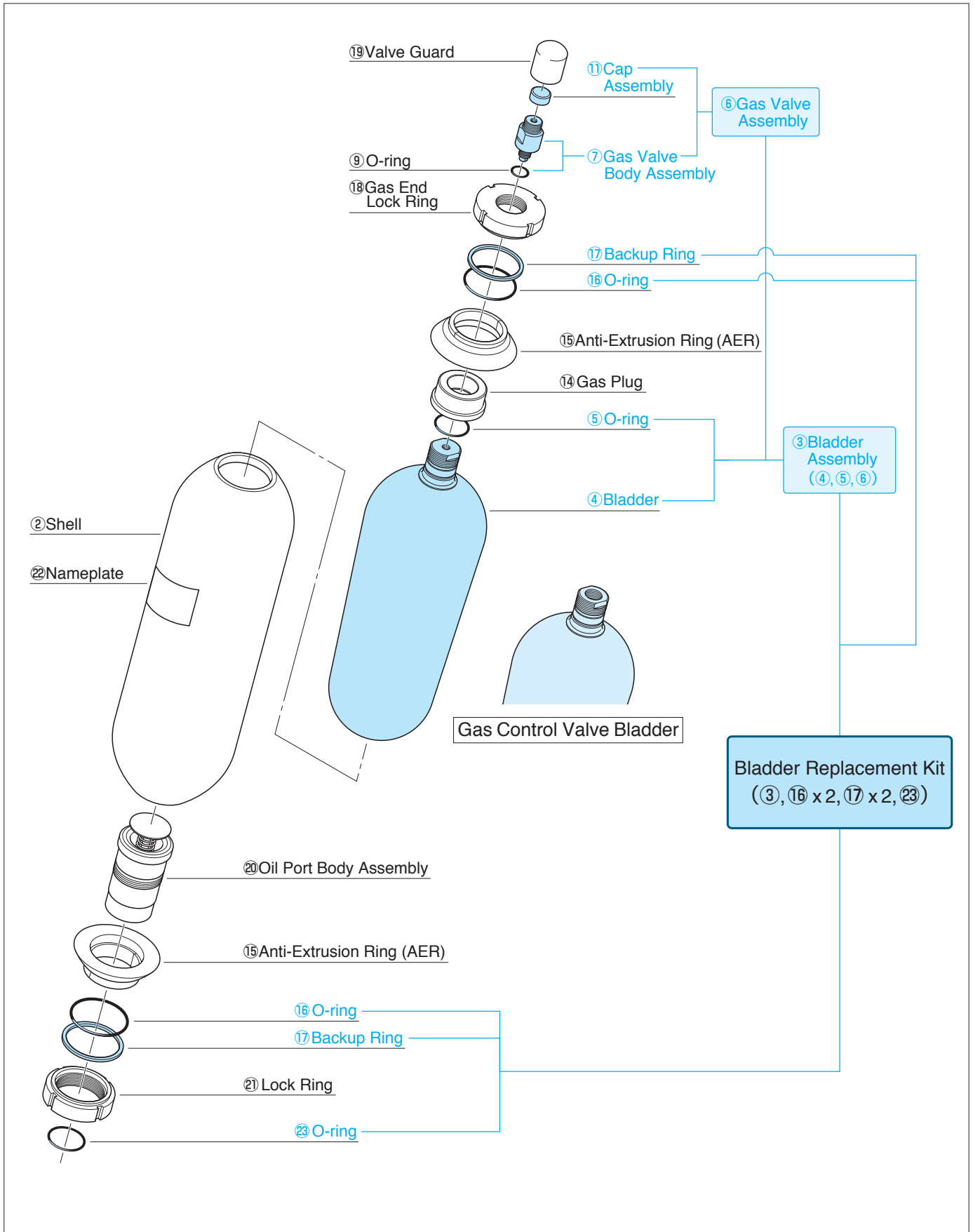

■ For Gas Valve Types (Standard Type)

Volume Category	Applicable Accumulators		Bladder Replacement Kit (Includes Sealing Materials)	
			Model Code	Product Code
10 ℓ	AT18M-10-30, -SH, /E AT35M-10-30, -SH, /E *AT150-10-30, -SH, /E *AT250-10-30, -SH, /E	AT25M-10-30, -SH, /E *AT175-10-30, -SH, /E *AT350-10-30, -SH, /E	PAT150-10-30	EB1313 B1
20 ℓ	AT18M-20-30, -SH, /E AT35M-20-30, -SH, /E *AT150-20-30, -SH, /E *AT250-20-30, -SH, /E	AT25M-20-30, -SH, /E *AT175-20-30, -SH, /E *AT350-20-30, -SH, /E	PAT150-20-30	EB1319 B1
30 ℓ	AT18M-30-30, -SH, /E AT35M-30-30, -SH, /E *AT150-30-30, -SH, /E *AT250-30-30, -SH, /E	AT25M-30-30, -SH, /E *AT175-30-30, -SH, /E *AT350-30-30, -SH, /E	PAT150-30-30	EB1325 B1
	AT23M-30-30, -SH, /E	*AT210-30-30, -SH, /E	PAT210-30-30	EB1513 B1
40 ℓ	AT23M-40-30, -SH, /E	*AT210-40-30, -SH, /E	PAT210-40-30	EB1515 B1
50 ℓ	AT18M-50-30, -SH, /E *AT150-50-30, -SH, /E *AT250-50-30, -SH, /E	AT25M-50-30, -SH, /E *AT175-50-30, -SH, /E *AT350-50-30, -SH, /E	PAT150-50-30	EB1331 B1
	AT23M-50-30, -SH, /E	*AT210-50-30, -SH, /E	PAT210-50-30	EB1517 B1
60 ℓ	AT23M-60-30, -SH, /E	*AT210-60-30, -SH, /E	PAT210-60-30	EB1337 B1

■ For Gas Control Valve Types (Includes O-ring for the gas control valve and backup ring)

Volume Category	Applicable Accumulators		Bladder Replacement Kit (Includes Sealing Materials)	
			Model Code	Product Code
10 ℓ	AT18M-10GC-30, -SH AT35M-10GC-30, -SH *AT150-10GC-30, -SH *AT250-10GC-30, -SH	AT25M-10GC-30, -SH *AT175-10GC-30, -SH *AT350-10GC-30, -SH	PAT150-10GC-30	EB1316 B1
20 ℓ	AT18M-20GC-30, -SH AT35M-20GC-30, -SH *AT150-20GC-30, -SH *AT250-20GC-30, -SH	AT25M-20GC-30, -SH *AT175-20GC-30, -SH *AT350-20GC-30, -SH	PAT150-20GC-30	EB1322 B1
30 ℓ	AT18M-30GC-30, -SH AT35M-30GC-30, -SH *AT150-30GC-30, -SH *AT250-30GC-30, -SH	AT25M-30GC-30, -SH *AT175-30GC-30, -SH *AT350-30GC-30, -SH	PAT150-30GC-30	EB1328 B1
	AT23M-30GC-30, -SH	*AT210-30GC-30, -SH	PAT210-30GC-30	EB1522 B1
40 ℓ	AT23M-40GC-30, -SH	*AT210-40GC-30, -SH	PAT210-40GC-30	EB1523 B1
50 ℓ	AT18M-50GC-30, -SH *AT150-50GC-30, -SH *AT250-50GC-30, -SH	AT25M-50GC-30, -SH *AT175-50GC-30, -SH *AT350-50GC-30, -SH	PAT150-50GC-30	EB1334 B1
	AT23M-50GC-30, -SH	*AT210-50GC-30, -SH	PAT210-50GC-30	EB1524 B1
60 ℓ	AT23M-60GC-30, -SH	*AT210-60GC-30, -SH	PAT210-60GC-30	EB1340 B1

The products with an asterisk (*) are listed in the previous catalog.

Please designate Model Code and Product Code in your order.

Rubber material replacement kit for the standard nitrile rubber (material mark: -30).
Consult your nearest sales contact if you require any other rubber materials than standard.

3 AT series Bladder Replacement Kit (Includes Sealing Materials)

10 ℓ ~ 50 ℓ (for HF, MH and UH series)

Ensure to specify the Model Code and Product Code of the kit when purchasing.

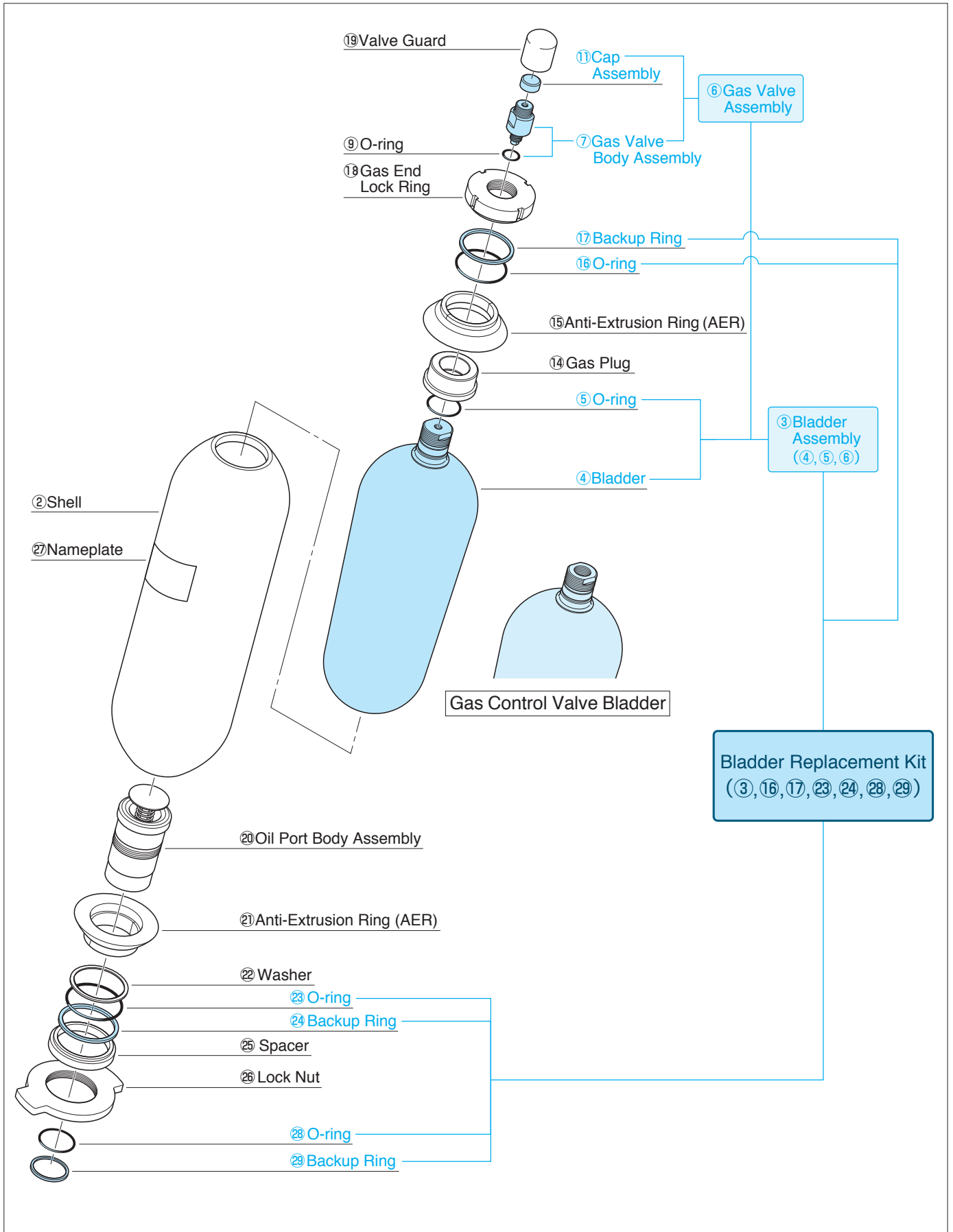

■ For Gas Valve Types (Standard Type)

Volume Category	Applicable Accumulators	Bladder Replacement Kit (Includes Sealing Materials)	
		Model Code	Product Code
10 ℓ	AT25M-10-30-HF, -MH, -UH, /E *AT250-10-30-HF, -MH, -UH, /E	PAT250-10-30-HF	EB1351 B1
20 ℓ	AT25M-20-30-HF, -MH, -UH, /E *AT250-20-30-HF, -MH, -UH, /E	PAT250-20-30-HF	EB1354 B1
30 ℓ	AT25M-30-30-HF, -MH, -UH, /E *AT250-30-30-HF, -MH, -UH, /E	PAT250-30-30-HF	EB1357 B1
40 ℓ	AT23M-40-30-HF, -MH, -UH, /E *AT210-40-30-HF, -MH, -UH, /E	PAT210-40-30-HF	EB1541 B1
50 ℓ	AT25M-50-30-HF, -MH, -UH, /E *AT250-50-30-HF, -MH, -UH, /E	PAT250-50-30-HF	EB1360 B1

■ For Gas Control Valve Types (Includes O-ring for the gas control valve and backup ring)

Volume Category	Applicable Accumulators	Bladder Replacement Kit (Includes Sealing Materials)	
		Model Code	Product Code
10 ℓ	AT25M-10GC-30-HF, -MH, -UH *AT250-10GC-30-HF, -MH, -UH	PAT250-10GC-30-HF	EB1553 B1
20 ℓ	AT25M-20GC-30-HF, -MH, -UH *AT250-20GC-30-HF, -MH, -UH	PAT250-20GC-30-HF	EB1556 B1
30 ℓ	AT25M-30GC-30-HF, -MH, -UH *AT250-30GC-30-HF, -MH, -UH	PAT250-30GC-30-HF	EB1559 B1
40 ℓ	AT23M-40GC-30-HF, -MH, -UH *AT210-40GC-30-HF, -MH, -UH	PAT210-40GC-30-HF	EB1562 B1
50 ℓ	AT25M-50GC-30-HF, -MH, -UH *AT250-50GC-30-HF, -MH, -UH	PAT250-50GC-30-HF	EB1565 B1

The products with an asterisk (*) are listed in the previous catalog.

Please designate Model Code and Product Code in your order.

Rubber material replacement kit for the standard nitrile rubber (material mark: -30).
Consult your nearest sales contact if you require any other rubber materials than standard.

4 AT series Bladder Replacement Kit (Includes Sealing Materials)

80 ℓ ~ 160 ℓ (for Standard, MH and UH series)

Ensure to specify the Model Code and Product Code of the kit when purchasing.

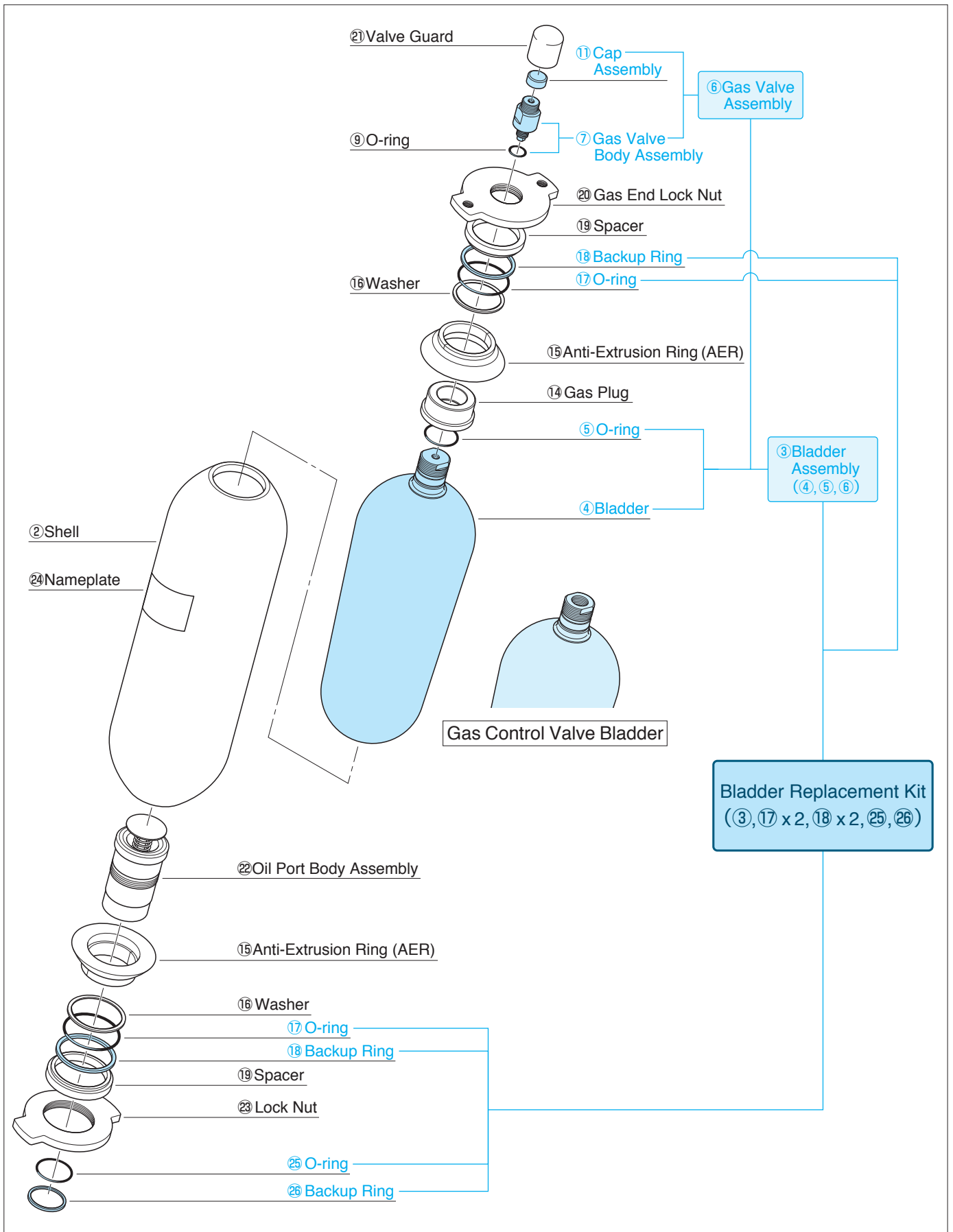

■ For Gas Valve Types (Standard Type)

Volume Category	Applicable Accumulators	Bladder Replacement Kit (Includes Sealing Materials)	
		Model Code	Product Code
80 ℓ	AT23M-80-30, -MH, -UH, /E *AT210-80-30, -MH, -UH, /E	PAT210-80-30	EB1526 B1
120 ℓ	AT23M-120-30, -MH, -UH, /E *AT230-120-30, -MH, -UH, /E	PAT230-120-30	EB1519 B1
150 ℓ 160 ℓ	AT23M-150-30, -MH, -UH, /E AT23M-160-30, -MH, -UH, /E *AT230-150-30, -MH, -UH, /E *AT210-160-30, -MH, -UH, /E	PAT230-150-30	EB1347 B1

■ For Gas Control Valve Types (Includes O-ring for the gas control valve and backup ring)

Volume Category	Applicable Accumulators	Bladder Replacement Kit (Includes Sealing Materials)	
		Model Code	Product Code
80 ℓ	AT23M-80GC-30, -MH, -UH *AT210-80GC-30, -MH, -UH	PAT210-80GC-30	EB1568 B1
120 ℓ	AT23M-120GC-30, -MH, -UH *AT230-120GC-30, -MH, -UH	PAT230-120GC-30	EB1574 B1
150 ℓ 160 ℓ	AT23M-150GC-30, -MH, -UH AT23M-160GC-30, -MH, -UH *AT230-150GC-30, -MH, -UH *AT210-160GC-30, -MH, -UH	PAT230-150GC-30	EB1583 B1

The products with an asterisk (*) are listed in the previous catalog.

Please designate Model Code and Product Code in your order.

Rubber material replacement kit for the standard nitrile rubber (material mark: -30).
Consult your nearest sales contact if you require any other rubber materials than standard.

21. Accumulator Handling Precautions

1. Verify using the nameplate of the accumulator that it is in fact the product you ordered.
2. Never use an accumulator at a pressure exceeding its maximum working pressure.
3. Install the accumulator firmly by the fixing band or other means.
4. Typically the equipment will not have been filled with nitrogen gas when shipped from the factory. Ensure to fill with gas prior to use.
Ensure not to use an accumulator before being filled with gas or the bladder could be damaged. (The MU, MUV and ET series are delivered with nitrogen gas filled at a factory.)
5. Ensure to fill the accumulator with nitrogen gas.
 - Never use oxygen or any inflammable gas.
 - Ensure not to use air as it could also shorten the life of the bladder.
6. Ensure to attach a reduction valve to the nitrogen cylinder so that the gas can be filled in a safe and easy manner.
7. Ensure to release the fluid pressure before filling with gas or checking the gas pressure.
Before releasing the fluid pressure ensure to utilize a bypass pipe (depressurizing pipe) or drain positioned between the main pipe and the accumulator.
8. Carry out the periodic maintenance and inspections of the accumulator (approximately twice a year).
 - ① Filled Gas Pressure: Add more gas if insufficient.
 - *Nitrogen gas will typically permeate from the bladder causing the gas pressure to drop. (See the next page for gas permeation and usage precautions.)
 - ② Check for any external nitrogen gas or fluid leaks.
 - ③ Check for any damage to the accumulator, loosened screws or other abnormalities.
9. Ensure not to use any other fluid than the factory recommendation or it could result in the bladder being swollen or the lifespan being drastically reduced.
10. Ensure the fluid and gas pressures are at atmospheric pressure before any part disassembly or removal work.
11. Ensure all the nitrogen gas has been removed from the accumulator prior to storage.
12. Before disposing of the accumulator ensure to completely remove any nitrogen gas, and then remove the core, gas valve or gas control valve in thereby ensuring it cannot be reused.
 - Ensure adequate ventilation of the room when removing any gas from the accumulator. (The room could become saturated with nitrogen gas and result in an oxygen deficiency.)
 - Welding or other processing of accumulators is strictly prohibited.

Contact your nearest sales contact regarding any necessary on-site gas filling or part replacement services.

Gas Permeation and Usage Precautions

Gases can permeate through rubber and other polymeric membranes. This phenomenon involves the gas dissolving through from either side of the rubber membrane, spreading into the membrane due to the differing concentrations of dissolved gas, and then passing through to the other side of the membrane. Rubber balloons becoming deflated or the drop in air pressure of tires over time are both examples of gas permeation having occurred.

Nitrogen gas in an accumulator will also permeate through the rubber membrane of a diaphragm into the operating oil (fluid).

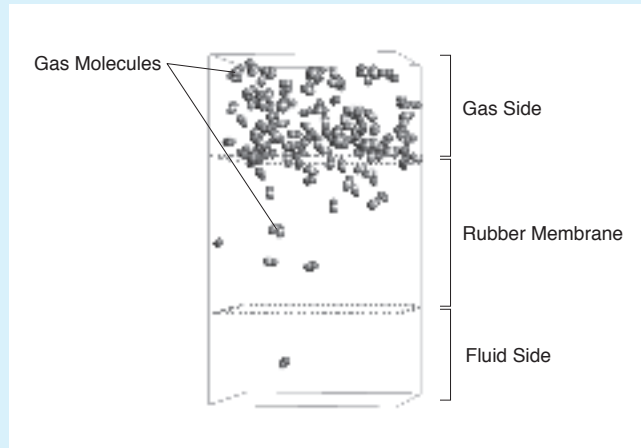

Polymeric Membrane Gas Permeation Model

Relationship between Temperature of Accumulator and Decrease in Gas Pressure

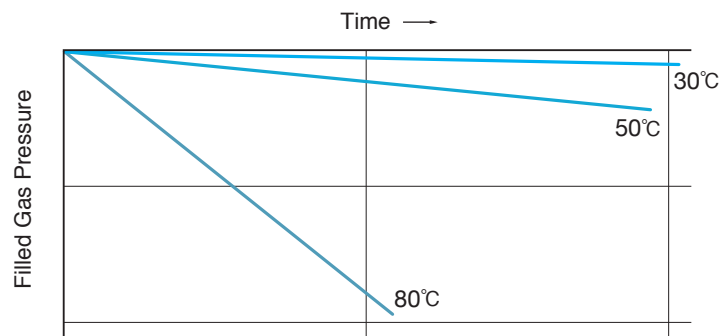

Any increase in temperature can accelerate the gas permeation process. Constant use of an accumulator in a high temperature region, therefore, will require more frequent than usual gas pressure inspections and refills. If Type A (0.5, 1 or 2 μ) of the MU or ET series, which is rather small in volume and incapable of being refilled with gas, is always used in a high temperature region then the useful lifespan will be less than usual.

If an accumulator is left filled with gas or the operating pressure has been retained at the filled gas pressure or less, then little gas will penetrate through as the bladder will be tightly adhered to the shell.

Please consult your sales contact if you have any inquiries regarding the gas permeation process and inspection frequency.

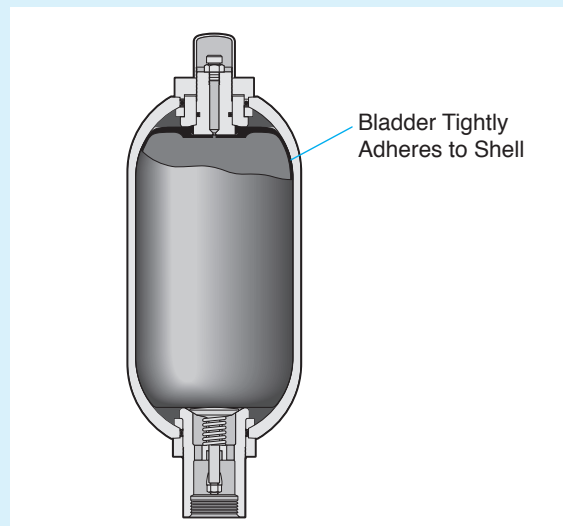

22. High Pressure Gas Safety Law and Procedure

The use of accumulators in Japan is subject to the “High Pressure Gas Safety Law” and “Industrial Safety and Health Law”.

The High Pressure Gas Safety Law has precedence over any others with use of accumulators of any volume used at a pressure of 1 MPa or more.

Customers using any accumulator subject to the “High Pressure Gas Safety Law” may be required to apply for permission or submit a notification regarding their use to the prefectural governor. Whether or not an application is required can be determined using the below flowchart, and ensure to contact your nearest sales contact if you do as they can provide you with the necessary documents.

Flowchart of Legal Classification and Necessity for Permission or Notifications regarding Use

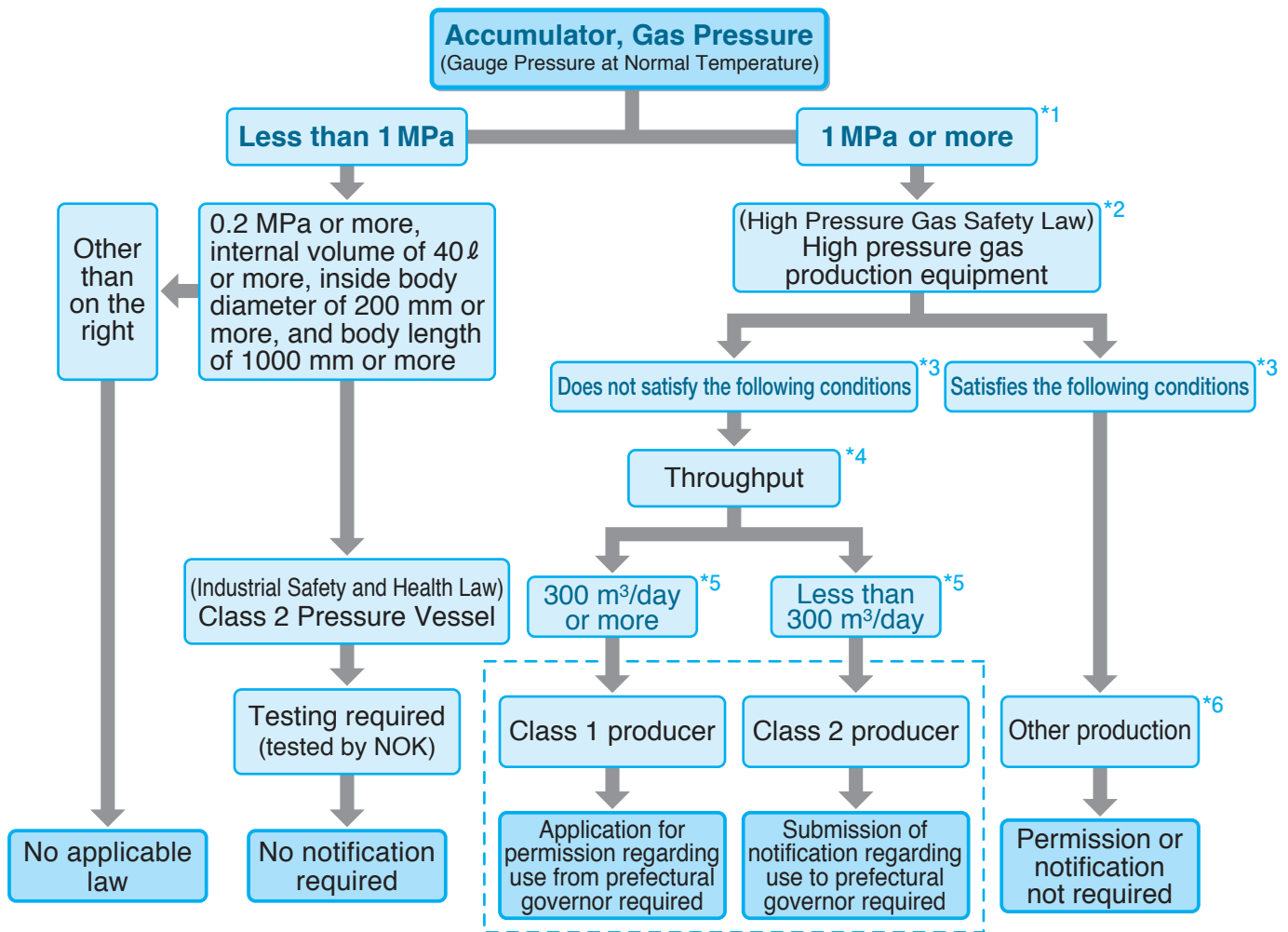

Conditional (No permission or notification is required)

As per Article 13 of the General Rule

Any accumulator that satisfies all the following conditions falls under “Other Production” and therefore does not require any special permission or notifications:

- (1) Filled with inert gas or air;
- (2) Not connected to any external gas source via pipes; and
- (3) Structurally limited pressure is below the design pressure (The following a or b must be satisfied:)
 - a. The accumulator is equipped with a spring safety valve, fusible plug, pressure release plate, etc.
 - b. The pipe connected to the liquid phase of the accumulator is equipped with a relief valve or automatic pressure controller.

Example Accumulator that does not require Permission or Notifications

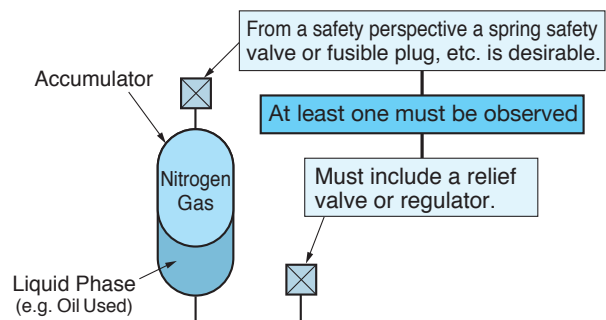

Follow the latest regulations as they are constantly updated.

Notes (Information with regard to the asterisks)

- *1. As per Article 2, Paragraph 1 of the Law.
- *2. The “High Pressure Gas Safety Law” deems accumulators, unlike other regular cylinders, to be “high-pressure gas production equipment” that produces highly pressurized gas. Those customers using the equipment or machine equipped with the accumulator are deemed to be the producers of high-pressure gas.
- *3. Any accumulator not satisfying those conditions requires the permission of or notifications regarding use to the prefectural governor.
Permission or notification applications require documents concerning the accumulator. Please ensure to request any such documents when purchasing an accumulator.

Documents NOK provides include: “Tested by a Qualified Tester, etc. Certification”, or “Record of High Pressure Gas Equipment, etc. Test”, “Strength Calculation Document”, “Material Certificate”, “Structural Drawings”, etc.

- *4. Article 2, Paragraph 18 of General Rule: Throughput

Throughput $Q_9 = V_9 \times 10 P_9$

Q₉: Throughput of Accumulator (m³/day)

V₉: Internal Volume of Accumulator (m³)

P₉: Maximum Compression Pressure of Accumulator (MPa)
(Converted to at 0 °C and 0 Pascal)

Example Calculation: When an accumulator with a gas volume of 150 ℓ is used at the normal temperature of 50 °C and a maximum working pressure of 21 MPa:

$$\text{Throughput} = (150 \times 10^{-3}) \times (21 \times 10) \times \frac{273}{(273 + 50)} = 26.6 \text{ (m}^3\text{/day)}$$

- *5. “Nitrogen” according to Article 5, Paragraph 1, of the Law and Article 3, Paragraph 1, of the Cabinet Order.
- *6. Other Production
Accumulators that do not fall under being concerned with a Class 1 Producer or Class 2 Producer do not require permission from or notifications regarding use to the prefectural governor. (They fall under being part of “Other Production” if they satisfy all the conditions.)

Personnel filling an accumulator with gas do not require any particular qualifications unless the accumulator is intended to be part of the sales of gas.

23. Accumulator Volume Calculation

The accumulator volume is basically calculated on the basis of $P_1V_1^n = P_2V_2^n = P_3V_3^n$, although the formula used can vary by application. See the following methods of calculation and examples.

[Methods of Calculation used in Individual Applications and Examples]	Page
① Energy Accumulation	60
② Pulse Absorption	62
③ Impact Absorption	64
④ Thermal Expansion Compensation	66

■ Example of Energy Conservation Resulting from Use of an Accumulator

The comparison between the required power with and without an accumulator included in the systems below indicates the use of an accumulator can reduce the necessary power to around a twentieth of that without one.

[Operating Conditions]

- Ram Load : 10.7 Ton
- Load Pressure : 10.5 MPa
- Average Ram Speed : 5 cm/s
- Stroke : 15 cm
- Operating Frequency : 0.5 cycle/m
- Pump Pressure : 21 MPa

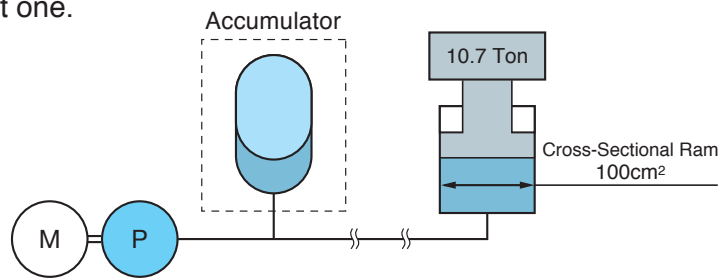

Item	Accumulator	
	With	Without
Required Amount of Oil	$100 \text{ cm}^2 \times 15 \text{ cm} = 1500 \text{ cm}^3 = 1.5 \text{ l}$	
Flow Rate Required per Second	$100 \text{ cm}^2 \times 5 \text{ cm/s} = 500 \text{ cm}^3/\text{s} = 0.5 \text{ l/s}$	
Flow Rate Required to Accumulate Pressure in Accumulator	Necessary Discharge Flow of Accumulator = Required Amount of Oil = 1.5 l Discharge Period $\frac{1.5 \text{ l}}{0.5 \text{ l/s}} = 3 \text{ s}$ Accumulation Period $120 \text{ s} - 3 \text{ s} = 117 \text{ s}$ Accumulating Flow $1.5 \text{ l}/117 \text{ s} = 0.013 \text{ l/s}$	—
Necessary Discharge Flow of Pump	0.013 l/s	0.5 l/s
Horsepower of Motor	$0.013 \text{ l/s} \times 21.0 \text{ MPa} = 0.27 \text{ kw}$	$0.5 \text{ l/s} \times 10.5 \text{ MPa} = 5.25 \text{ kw}$

Terms Related to Accumulator Pressure

Maximum Working Pressure: All accumulators are designed to be used at a specific pressure or lower as a pressure vessel that contains high pressure gas. This pressure is referred to as the maximum working pressure.

System Pressure: The maximum possible pressure of a circuit, and generally used to refer to the release pressure of a relief valve mounted on the equipment or machinery. The primary condition when selecting an accumulator is therefore that its maximum working pressure be equal to or exceed the system pressure. Select the appropriate Model Code according to the List of Model Codes and Dimensions for each series whenever the maximum working pressure is known.

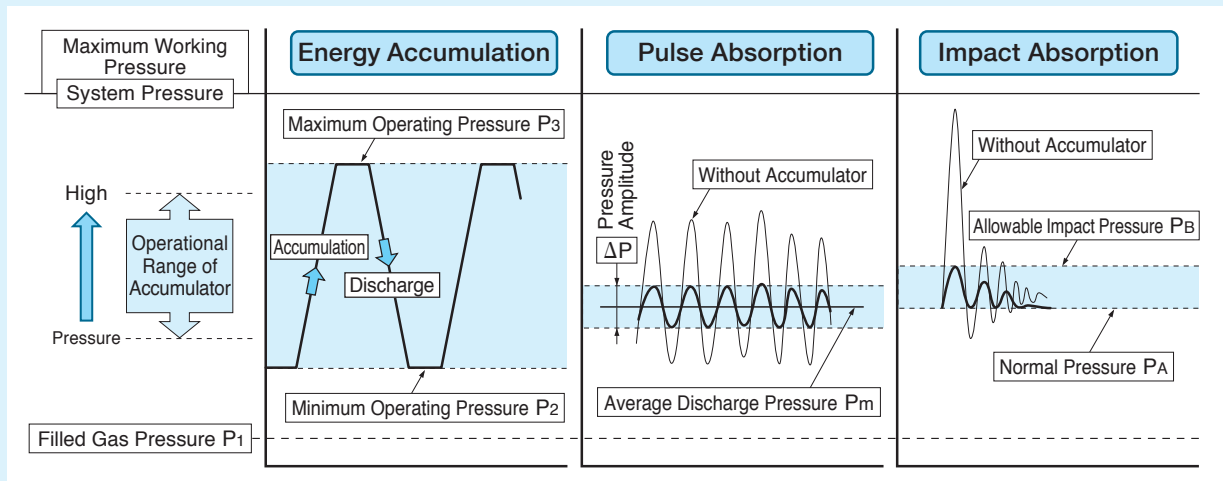

Maximum Operating Pressure P_3 : The maximum applicable pressure at which gas can be compressed in an accumulator.

Minimum Operating Pressure P_2 : The minimum pressure when fluid is discharged from an accumulator.

Filled Gas Pressure P_1 : Seal pressure of nitrogen gas.

Average Discharge Pressure P_m : The average pressure of fluid discharged from a pump, etc.

Normal Pressure P_A : The pressure within a pipe with no impact pressure.

Allowable Impact Pressure P_B : Maximum allowable impact pressure. The higher the allowable impact pressure is the smaller in volume the accumulator can be.

Basic Formula Used with and Operating Conditions of Accumulators

$$P_1 V_1^n = P_2 V_2^n = P_3 V_3^n$$

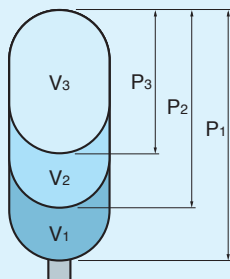

- P_1 : Filled Gas Pressure
- P_2 : Minimum Operating Pressure
- P_3 : Maximum Operating Pressure
- V_1 : Gas Volume at P_1
- V_2 : Gas Volume at P_2
- V_3 : Gas Volume at P_3
- n : Polytropic Index
(Index determined by fluctuation time of gas pressure)

Fill with nitrogen gas

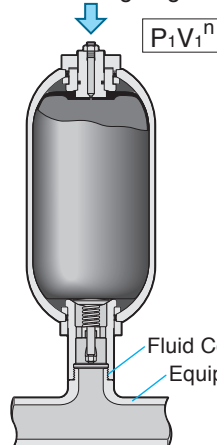

Filled with Nitrogen Gas
The bladder expands and the poppet closes.

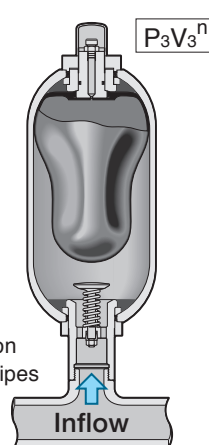

Fluid Flowing in
When the fluid pressure reaches the filled gas pressure the poppet then opens and accumulation takes place until the pressure reaches the maximum operating pressure.

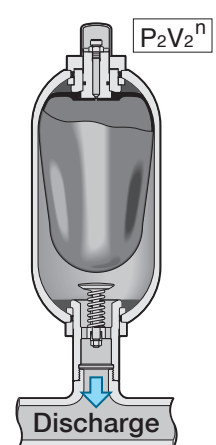

Fluid Discharged
Fluid is discharged until the minimum operating pressure is reached.

① Energy Accumulation

With intermittent operation (i.e. time available for accumulation to take place in the accumulator) the use of an accumulator can enable downsizing of the volume of the pump and motor, thus contributing to greater energy conservation.

1. Calculate the required gas volume (V₁) that fulfills the aims of the usage conditions.

■ Set Filled Gas Pressure (P₁)

Set the pressure according to either ① or ②.

$P_1 \geq (1/\text{Max. compression ratio}) \times P_3$ must still be satisfied.

(See pages 10 and 11 for the maximum compression ratios of the individual series)

① If no change in temperature: $P_1 = (0.8 \sim 0.9) \times P_2$

② Change in temperature takes place: $P_1 = \frac{273 + \text{Minimum temperature (Tmin)}}{273 + \text{Maximum temperature (Tmax)}} \times (0.8 \sim 0.9) \times P_2$

■ Set Polytropic Indices (m, n)

Indices m and n can be calculated using the formula below or more simply Table 1.

If the inflow time exceeds 40s then assume $m = 1$.

$$m \text{ or } n = \left(\frac{0.63}{\Delta t^{0.5}} + 1.01 \right) (1.94 \times 10^{-2} \times P_m + 1.12)$$

(Δt : Fluctuation Time with Inflow or Discharge (s)
If Δt is less than 10s then use the values in Table-1 for m and n)

■ Calculate Necessary Gas Volume (V₁)

$$V_1 = \Delta V \times \frac{P_2^{\frac{1}{n}} \cdot P_3^{\frac{1}{m}}}{P_1^{\frac{1}{m}} (P_3^{\frac{1}{n}} - P_2^{\frac{1}{n}})}$$

Convert the value to the absolute pressure in the calculation if the accumulator only has to support a pressure of 1 MPa or less.

[Absolute Pressure = Gauge Pressure + 0.1013 (MPa)]

Description of Symbols Used

V ₁ : Necessary Gas Volume	ℓ
ΔV: Necessary Discharge Flow	ℓ
P ₁ : Filled Gas Pressure	MPa
P ₂ : Minimum Operating Pressure	MPa
P ₃ : Maximum Operating Pressure	MPa
P _m : Average Operating Pressure	MPa
$P_m = \frac{(P_2 + P_3)}{2}$	
m: Polytropic Index when Fluid Flows in	
n: Polytropic Index when Fluid Is Discharged	

2. Select the Model Code of the accumulator

Select an accumulator from any series that satisfies all of Necessary Gas Volume (V₁) ≤ Gas Volume of Accumulator, System Pressure (P_{max}) ≤ Maximum Working Pressure, and Necessary Discharge Flow (Q_{max}) ≤ Maximum Discharge Flow.

<Table-1> List of Polytropic Indices (m and n values)

Pm (MPa)	Δt (s)	m n	Less Than 10	10 or More Less Than 20	20 to 40	If the Inflow Time Exceeds 40s Then m = 1 can be Consistently Used.						
						40 to 60	60 to 80	80 to 100	100 to 200	200 to 400	400 to 700	700 or more
2.0 or more	2.0 less than		1.47	1.34	1.28	1.25	1.24	1.23	1.21	1.19	1.18	1.17
	2.9		1.51	1.37	1.31	1.28	1.27	1.26	1.24	1.22	1.21	1.20
2.9	3.9		1.53	1.39	1.33	1.31	1.29	1.28	1.26	1.24	1.23	1.22
3.9	4.9		1.56	1.41	1.36	1.33	1.31	1.30	1.28	1.26	1.25	1.24
4.9	5.9		1.58	1.44	1.38	1.35	1.33	1.32	1.30	1.28	1.27	1.26
5.9	6.9		1.61	1.46	1.40	1.37	1.35	1.34	1.32	1.30	1.29	1.28
6.9	7.8		1.63	1.48	1.42	1.39	1.37	1.36	1.34	1.32	1.31	1.30
7.8	8.8		1.66	1.50	1.44	1.41	1.39	1.38	1.36	1.34	1.33	1.32
8.8	9.8		1.68	1.53	1.46	1.43	1.41	1.40	1.38	1.36	1.35	1.34
9.8	10.8		1.70	1.55	1.48	1.45	1.43	1.42	1.40	1.38	1.37	1.36
10.8	11.8		1.73	1.57	1.51	1.47	1.45	1.44	1.42	1.40	1.39	1.38
11.8	12.7		1.75	1.59	1.53	1.49	1.47	1.46	1.44	1.42	1.41	1.40
12.7	13.7		1.78	1.61	1.55	1.51	1.49	1.48	1.46	1.44	1.43	1.42
13.7	14.7		1.80	1.64	1.57	1.53	1.51	1.50	1.48	1.46	1.45	1.44
14.7	15.7		1.83	1.66	1.59	1.55	1.54	1.52	1.50	1.48	1.47	1.46
15.7	16.7		1.85	1.68	1.61	1.58	1.56	1.54	1.52	1.50	1.49	1.48
16.7	17.7		1.88	1.70	1.63	1.60	1.58	1.56	1.54	1.52	1.51	1.50
17.7	18.6		1.90	1.73	1.66	1.62	1.60	1.58	1.56	1.54	1.53	1.52
18.6	19.6		1.93	1.75	1.68	1.64	1.62	1.60	1.58	1.56	1.55	1.54
19.6	21.6		1.96	1.78	1.71	1.67	1.65	1.64	1.61	1.59	1.58	1.57
21.6	23.5		2.01	1.83	1.75	1.71	1.69	1.68	1.65	1.63	1.62	1.61
23.5	25.5		2.06	1.87	1.79	1.75	1.73	1.72	1.69	1.67	1.66	1.64
25.5	27.5		2.11	1.91	1.84	1.79	1.77	1.76	1.73	1.71	1.70	1.68
27.5	29.4		2.16	1.96	1.88	1.84	1.81	1.80	1.77	1.75	1.75	1.72

Example Calculation

Select an accumulator with the necessary discharge flow [ΔV] set to be 4L for the hydraulic lines and using the maximum operating pressure [P_3 : 21.0 MPa] and minimum operating pressure [P_2 : 12.0 MPa]. The accumulation period [Δt_m] (duration required for the oil to flow into the accumulator and reach the maximum operating pressure) will be 41s and the discharge period [Δt_n] (duration required for the oil to be discharged from the accumulator and reach the minimum operating pressure) 10s. The operating temperature should be between -10 and 60 °C.

Page 69 The Volume Calculation Sheet on ① Accumulator for Energy Accumulation can be used with:

Fill in the columns within the thick frame. Consult your nearest sales contact regarding any additional inquiries.

Volume Calculation Sheet

① Accumulator for Energy Accumulation

(To be completed by NOK)

Data

Name and Section

Equipment and Machinery, Installation Position

Set Conditions of Use

Applicable Fluid		<i>Common Mineral Hydraulic Oil</i>	
Temperature Conditions	Fluid Temperature	~	°C Normal Temperature °C
	Ambient Temperature	- 10 ~ 60	°C Normal Temperature °C

System Pressure	Pmax	22.0 MPa	Maximum possible pressure applied to an accumulator in a circuit, and typically used to refer to the release pressure of a relief valve with the equipment or machinery.
Maximum Operating Pressure	P ₃	21.0 MPa	Maximum pressure of accumulated fluid in the accumulator
Minimum Operating Pressure	P ₂	12.0 MPa	Minimum pressure when fluid is discharged from the accumulator
Average Operating Pressure	P _m	16.5 MPa	P _m =(P ₃ +P ₂)/2
Necessary Discharge Flow	ΔV	4 ℓ	Total amount of fluid required for piston (actuator) operation
Accumulation Period	Δt_m	41 s	Time required to accumulate ΔV in the accumulator
Discharge Period	Δt_n	10 s	Time required to discharge ΔV from the accumulator

Calculate Necessary Gas Volume V₁ Convert the value to the absolute pressure for use in calculation if the accumulator is used at 1 MPa or less. [Absolute Pressure (MPa) = Gauge Pressure + 0.1013]

■ Set Filled Gas Pressure (P₁) Set the pressure according to either ① or ②. P₁ ≥ (1/Max. compression ratio) × P₃ must still be satisfied. (See pages 10 and 11 for the maximum compression ratios of the individual series)

① If no change in temperature takes place: P₁ = (0.8~0.9) × P₂ = 0.85 × 12.0 = 10.2 MPa

② If the temperature changes: P₁ = $\frac{273+T_{min}}{273+T_{max}} \times (0.8\sim 0.9) \times P_2 = \frac{273+(-10)}{273+60} \times 0.85 \times 12.0 = 8.06$ MPa

■ Set Polytropic Indices
Set the indices from the [List of Polytropic Indices] on page 60.

When Accumulated (m)	...	P _m 16.5 , Δt_m 41 ; 1
When Discharged (n)	...	P _m 16.5 , Δt_n 10 ; 1.68

■ Calculate Necessary Gas Volume for Accumulator (V₁)

$$V_1 = \Delta V \times \frac{P_2^{\frac{1}{n}} \cdot P_3^{\frac{1}{m}}}{P_1^{\frac{1}{m}} \left(P_3^{\frac{1}{n}} - P_2^{\frac{1}{n}} \right)} = 4 \times \frac{12.0^{\frac{1}{1.68}} \times 21.0^{\frac{1}{1}}}{8.06^{\frac{1}{1}} \times \left(21.0^{\frac{1}{1.68}} - 12.0^{\frac{1}{1.68}} \right)} = 26.4 \text{ ℓ}$$

Verify Necessary Discharge Flow Q_{max} Q_{max} = $\Delta V \times 60 / \Delta t_n = 4 \times 60 / 10 = 24$ ℓ/min

Select a NOK Accumulator Model Select a model that satisfies "V₁ ≤ Accumulator Gas Volume" from the individual series listed on pages 12 to 31

Select an accumulator with which the necessary discharge flow Q_{max} will not exceed the maximum discharge flow. Select the AT series if the bladder for the 10 ℓ or larger accumulator is replaced from the gas side.

- Select the series AT series according to the relevant P_{max}, V₁, Q_{max}. [Model Code of Selected Accumulator] [Gas Volume]
- Set the rubber material to Standard NBR (Nitrile Rubber) according to the fluid used and temperature. AT25M-30-30/□□ ; 34 ℓ
- Set the wetted specification to Standard Specifications according to the fluid used.
- Set the joint for fluid port connecting and specifications required by the gas side.

No. of Necessary Accumulators (V₁; 26.4 ℓ/Accumulator Gas Volume; 34 ℓ/unit) [Rounded to the nearest whole number] = 1 units

Verify the Discharge Flow ΔV_u of the Selected Accumulator

$$\Delta V_u = \text{Gas Volume} \times \frac{P_1^{\frac{1}{m}} \left(P_3^{\frac{1}{n}} - P_2^{\frac{1}{n}} \right)}{P_2^{\frac{1}{n}} \cdot P_3^{\frac{1}{m}}} = 34 \times \frac{8.06^{\frac{1}{1}} \times \left(21.0^{\frac{1}{1.68}} - 12.0^{\frac{1}{1.68}} \right)}{12.0^{\frac{1}{1.68}} \times 21.0^{\frac{1}{1}}} = 5.16 \text{ ℓ} \quad (\Delta V_u \geq \Delta V)$$

Handling and Selection

61

② Pulse Absorption

The use of an accumulator can attenuate pulses generated by a pump and reduce noise and vibration, while also improving stability.

1. Calculate the required gas volume (V_1) that fulfills the aims of the usage conditions.

■ Set Constant (K_1) using the Type of Pump

→ Set the constant using the table on the right.

■ Set Filled Gas Pressure (P_1)

Set the pressure according to either ① or ②.

① If no change in temperature: $P_1 = (0.6 \sim 0.8) \times P_m$

② Change in temperature takes place:

$$P_1 = \frac{273 + \text{Minimum temperature (Tmin)}}{273 + \text{Maximum temperature (Tmax)}} \times (0.6 \sim 0.8) \times P_m$$

■ Set Polytropic Indices (n)

Calculate the value using $n = 1.41$

■ Calculate the Discharge (q) per Pump Rotation

$$q = \frac{\text{Pump Discharge (ℓ/min)}}{\text{No. of Pump Rotations (rpm)}}$$

■ Set the Maximum Target Line Pressure (P_3)

$$P_3 = P_m + \frac{\Delta P}{2}$$

$$P_3 = \left(1 + \frac{\text{Target Ripple Factor}}{100}\right) \times P_m$$

ΔP : Pressure Amplitude with Accumulator

$$\text{Ripple Factor} = \frac{P_3 - P_m}{P_m} \times 100 (\%)$$

■ Calculate Necessary Gas Volume (V_1)

$$V_1 = \frac{q \cdot K_1 \cdot \left(\frac{P_m}{P_1}\right)^{\frac{1}{n}}}{1 - \left(\frac{P_m}{P_3}\right)^{\frac{1}{n}}}$$

Convert the value to the absolute pressure in the calculation if the accumulator only has to support a pressure of 1 MPa or less.
[Absolute Pressure = Gauge Pressure + 0.1013 (MPa)]

K_1 for Each Individual Type of Pump

Type of Pump	Number	K_1	
		Single-action	Double-action
Plunger Diaphragm	1	0.60	0.25
	2	0.25	0.15
	3	0.13	0.06
	4	0.10	0.06
	5	0.06	0.02
	6	0.06	
	7 or more	0.02	
Gear and Vane		0.06	

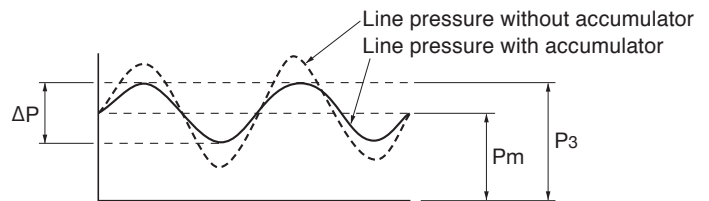

Description of Symbols Used

V_1 : Necessary Gas Volume	ℓ
P_1 : Filled Gas Pressure	MPa
P_m : Average Discharge Pressure	MPa
P_3 : Maximum Target Line Pressure	MPa
q : Discharge per Pump Rotation	ℓ / Rotation
K_1 : Constant that Varies by Type of Pump	
n : Polytropic Index	1.41 (Nitrogen gas)

2. Select the Model Code of the accumulator

Select an accumulator from any series that satisfies all of Necessary Gas Volume ($V_1 \leq$ Gas Volume of Accumulator), System Pressure ($P_{max} \leq$ Maximum Working Pressure), and Necessary Discharge Flow ($Q_{max} \leq$ Maximum Discharge Flow).

Absorbing the pulses from high frequency cycles and pipelines can be taken into account if the operating pressure conditions, the pulses and frequency at which they are generated, and the fluid pipe conditions are provided in thereby allowing the result of the accumulator to be increased. Contact your nearest sales contact for more details.

Example Calculation

Select an accumulator that attenuates the pulses generated by the following pumps:

Type of Pump: Triple Single-Action Plunger Pump Average Discharge Pressure P_m: 17.0 MPa
 Pump Discharge: 750 ℓ/min Target Ripple Factor: ± 3%
 No. of Pump Rotations: 1000 rpm

Page 70 The Volume Calculation Sheet on ② Accumulator Used to Absorb Pulses can be used with:

Fill in the columns within the thick frame. Consult your nearest sales contact regarding any additional inquiries.

Volume Calculation Sheet

② Accumulator Used to Absorb Pulses

(To be completed by NOK)

Data . . .

Name and Section

Equipment and Machinery, Installation Position

Set Conditions of Use

Applicable Fluid		Common Mineral Hydraulic Oil	
Temperature Conditions	Fluid Temperature	~	°C Normal Temperature °C
	Ambient Temperature	~	°C Normal Temperature Room Temperature °C

System Pressure	P _{max}	20.0	MPa	Maximum possible pressure applied to an accumulator in a circuit, and typically used to refer to the release pressure of a relief valve with the equipment or machinery. The average pressure of fluid discharged from a pump, etc.
Average Discharge Pressure	P _m	17.0	MPa	
Target Ripple Factor		± 3	%	
Type of Pump	<input checked="" type="checkbox"/> Plunger	Number	3	<input checked="" type="checkbox"/> Single-action
	<input type="checkbox"/> Diaphragm		<input type="checkbox"/> Double-action	
	<input type="checkbox"/> Gear	No. of Teeth		pcs.
	<input type="checkbox"/> Vane	No. of Blades		pcs.
	<input type="checkbox"/> Other			
Pump Specifications		Discharge	750	ℓ/min
		Rotations	1000	rpm

Calculate Necessary Gas Volume V₁ Convert the value to the absolute pressure for use in calculation if the accumulator is used at 1 MPa or less. [Absolute Pressure (MPa) = Gauge Pressure + 0.1013]

■ Set Constant (K₁) that will Vary with the Type of Pump Set the constant from the list of [Constant K₁ for Each Individual Type of Pump] from above. 0.13

■ Set Filled Gas Pressure (P₁) Set the pressure according to either ① or ②. P₁ ≥ (1/Max. compression ratio) × P₃ must still be satisfied. (See pages 10 and 11 for the maximum compression ratios of the individual series)

① If no change in temperature takes place: P₁ = (0.6~0.8) × P_m = 0.7 × 17.0 = 11.9 MPa

② If the temperature changes: P₁ = $\frac{273+T_{min}}{273+T_{max}} \times (0.6\sim 0.8) \times P_m$ = $\frac{273 +}{273 +} \times 0.7 \times$ = MPa

■ Calculate Discharge (q) per Pump Rotation q = Discharge/Rotations = 750 ÷ 1000 = 0.75 ℓ/Rotation

■ Set Polytropic Indices (n) Calculate the value using n = 1.41 (nitrogen gas)

■ Calculate Maximum Target Line Pressure (P₃) P₃ = (1 + Ripple Factor/100) × P_m = (1 + 3 / 100) × 17.0 = 17.51 MPa

■ Calculate Necessary Gas Volume (V₁) for Accumulator

$$V_1 = \frac{q \cdot K_1 \cdot \left(\frac{P_m}{P_1}\right)^{\frac{1}{n}}}{1 - \left(\frac{P_m}{P_3}\right)^{\frac{1}{n}}} = \frac{0.75 \times 0.13 \times \left(\frac{17.0}{11.9}\right)^{\frac{1}{1.41}}}{1 - \left(\frac{17.0}{17.51}\right)^{\frac{1}{1.41}}} = 6.05 \text{ ℓ}$$

Select a NOK Accumulator Model Select a model that satisfies "V₁ ≤ Accumulator Gas Volume" from the individual series listed on pages 12 to 31

Select the AT series if the bladder for the 10 ℓ or larger accumulator is replaced from the gas side.

· Select the series AT series according to the relevant P _{max} , V ₁ .	[Model Code of Selected Accumulator]	[Gas Volume]
· Set the rubber material to Standard NBR (Nitrile Rubber) according to the fluid used and temperature.	AT25M-10-30/□□	10 ℓ
· Set the wetted specification to Standard Specifications according to the fluid used.		
· Set the joint for fluid port connecting and specifications required by the gas side.		
No. of Necessary Accumulators (V ₁ ; 6.05 ℓ/Accumulator Gas Volume; 10 ℓ/unit) [Rounded to the nearest whole number] = 1 units		

Handling and Selection

63

③ Impact Absorption

The use of an accumulator can enable valves to be rapidly closed or to mitigate the impact pressure resulting from a sudden change in load, thus preventing the equipment from being damaged.

Examples of Impact Absorption

a. Shock buffering when a solenoid valve is switched

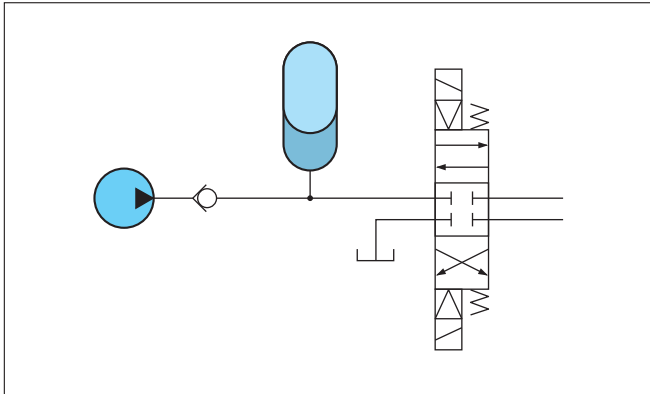

b. Shock buffering when a ram suddenly stops

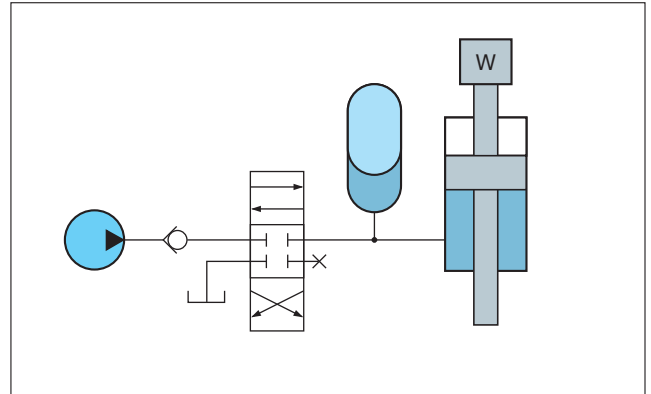

1. Calculate the required gas volume (V_1) that fulfills the aims of the usage conditions.

■ Set Filled Gas Pressure (P_1)

Set the pressure according to either ① or ②.

Ensure $P_1 \geq (1/\text{Max. compression ratio}) \times P_3$ must still be satisfied.

(See pages 10 and 11 for the maximum compression ratios of the individual series)

① If no change in temperature: $P_1 = (0.8 \sim 0.9) \times P_A$

② Change in temperature takes place: $P_1 = \frac{273 + \text{Minimum temperature (Tmin)}}{273 + \text{Maximum temperature (Tmax)}} \times (0.8 \sim 0.9) \times P_A$

■ Set Allowable Impact Pressure P_B

The value is generally set to be 110% of the normal pressure P_A . $P_B = 1.1 \times P_A$

■ Set Polytropic Indices (n)

Calculate the value using $n = 1.41$

■ Calculate Necessary Gas Volume (V_1)

$$V_1 = V \times \frac{P_A}{P_1}$$

Gas Volume at Normal Pressure P_A (V)

$$V = \frac{W \cdot v^2 \cdot (n - 1)}{200 \cdot P_A \cdot \left(\left(\frac{P_B}{P_A} \right)^{\frac{n-1}{n}} - 1 \right)}$$

This formula is used to calculate the volume required to make the impact absorption of the accumulator completely efficient. In reality, however, the effect could be the same with a smaller volume due to pipe resistance and other factors.

Convert the value to the absolute pressure in the calculation if the accumulator only has to support a pressure of 1 MPa or less.

[Absolute Pressure = Gauge Pressure + 0.1013 (MPa)]

Description of Symbols Used

V_1 : Necessary Gas Volume	ℓ
V : Gas Volume at P_A	ℓ
P_1 : Filled Gas Pressure	MPa
P_A : Normal Pressure	MPa
P_B : Allowable Impact Pressure	MPa
n : Polytropic Index	1.41 (Nitrogen gas)
ρ : Fluid Density	kg/m ³
d : Pipe Diameter (Inside Diameter)	mm
L : Pipe Length	m
Q : Fluid Flow Rate	ℓ /min
v : Fluid Velocity	m/s
W : Fluid Mass	kg

2. Select the Model Code of the accumulator

Select an accumulator from the appropriate series that satisfies Necessary Gas Volume (V_1) \leq Gas Volume and the Maximum Working Pressure being equal to or exceeding the System Pressure.

Example Calculation

Select an accumulator that can be used to buffer shocks generated when the direction of the flow is changed using a solenoid valve on a hydraulic line.

Pipe Diameter d : 3/4B Schedule 160 (Inside Diameter: 16.2 mm)

Pipe Length L : 15 m

Normal Pressure P_A : 11.0 MPa

Flow Rate Q : 250 ℓ/min

Fluid Density ρ : 900 kg/m³

Page 71 The Volume Calculation Sheet on ③ Accumulator Used to Absorb Impact can be used with:

Fill in the columns within the thick frame. Consult your nearest sales contact regarding any additional inquiries.

Volume Calculation Sheet

③ Accumulator Used to Absorb Impact

Equipment and Machinery, Installation Position

Set Conditions of Use

Applicable Fluid		<i>Common Mineral Hydraulic Oil</i>	
Temperature Conditions	Fluid Temperature	~	°C Normal Temperature
	Ambient Temperature	~	°C Normal Temperature <i>Room Temperature</i>
System Pressure	P_{max}	14.0	MPa Maximum possible pressure applied to an accumulator in a circuit, and typically used to refer to the release pressure of a relief valve with the equipment or machinery.
Normal Pressure	P_A	11.0	MPa The pressure within a pipe with no impact pressure.
Allowable Impact Pressure	P_B	12.1	MPa Maximum supported impact pressure. The higher the value the smaller in volume the accumulator can be. The value is generally set to be 110% of the normal pressure. ($P_B=11.0 \times 1.1=12.1$ MPa)
Fluid Density	ρ	900	kg/m ³ Be careful with the units used. The unit used for water is in [1000].
Inside Pipe Diameter	d	16.2	mm
Pipe Length	L	15	m
Flow Rate	Q	250	ℓ/min
Flow Velocity	v	—	m/s Not required if the "pipe diameter" and "flow rate" are provided.

(To be completed by NOK)

Data . . .

Name and Section

Calculate Necessary Gas Volume V_1 Convert the value to the absolute pressure for use in calculation if the accumulator is used at 1 MPa or less. [Absolute Pressure (MPa) = Gauge Pressure + 0.1013]

- Calculate Fluid Mass (W) within the Line $W = \frac{\pi}{4} \cdot d^2 \cdot L \cdot \rho \cdot 10^{-6} = \frac{\pi}{4} \times 16.2^2 \times 15 \times 900 \times 10^{-6} = 2.78$ kg
- Calculate Flow Velocity (v) $v = 21.23 \times Q / d^2 = 21.23 \times 250 \div 16.2^2 = 20.22$ m/s
- Set Filled Gas Pressure (P_1) Set the pressure according to either ① or ②. $P_1 \geq (1/\text{Max. compression ratio}) \times P_3$ must still be satisfied. (See pages 10 and 11 for the maximum compression ratios of the individual series)
 - ① If no change in temperature takes place: $P_1 = (0.8 \sim 0.9) \times P_A = 0.9 \times 11.0 = 9.9$ MPa
 - ② If the temperature changes: $P_1 = \frac{273+T_{min}}{273+T_{max}} \times (0.8 \sim 0.9) \times P_A = \frac{273}{273} \times 0.9 \times 11.0 = 9.9$ MPa
- Set Polytropic Indices (n) Calculate the value using $n = 1.41$ (nitrogen gas)
- Calculate Maximum Supported Impact Pressure (P_B) $P_B = 1.1 \times P_A = 1.1 \times 11.0 = 12.1$ MPa
- Calculate Accumulator Gas Volume (V_A) when Pressure is P_A

$$V_A = \frac{W \cdot v^2 \cdot (n - 1)}{200 \cdot P_A \times \left(\left(\frac{P_B}{P_A} \right)^{\frac{n-1}{n}} - 1 \right)} = \frac{2.78 \times 20.22^2 \times (1.41 - 1)}{200 \times 11.0 \times \left(\left(\frac{12.1}{11.0} \right)^{\frac{1.41-1}{1.41}} - 1 \right)} = 7.54$$
 ℓ
- Calculate Necessary Gas Volume (V_1) for Accumulator $V_1 = V_A \times \frac{P_A}{P_1} = 7.54 \times \frac{11.0}{9.9} = 8.38$ ℓ

Select a NOK Accumulator Model Select a model that satisfies " $V_1 \leq$ Accumulator Gas Volume" from the individual series listed on pages 12 to 31

Select the AT series if the bladder for the 10 ℓ or larger accumulator is replaced from the gas side.

- Select the series **AT series** according to the relevant P_{max}, V_1 . [Model Code of Selected Accumulator] [Gas Volume]
- Set the rubber material to **Standard NBR (Nitrile Rubber)** according to the fluid used and temperature. **AT18M-10-30/□□** **10 ℓ**
- Set the wetted specification to **Standard Specifications** according to the fluid used.
- Set the joint for fluid port connecting and specifications required by the gas side.

No. of Necessary Accumulators (V_1 ; **8.38** ℓ/Accumulator Gas Volume; **10** ℓ/unit) [Rounded to the nearest whole number] = **1** units

Handling and Selection

65

④ Thermal Expansion Compensation

Both the fluid and the pipes will expand in volume when a closed circuit consisting of pipes full of fluid heats up.

The thermal expansion coefficient for almost all fluids is typically a lot larger than that of most materials pipes are made of, and with the thermally-expanded portion of the fluid being greater than that of the pipe material, thus raising the pressure within the system (i.e. pipes). A rise in pressure within the system may exceed the design limits and thus damage the equipment used in the system. Any such system therefore requires a compensator to allow for the thermal expansion, with an accumulator being very effective.

1. Calculate the required gas volume (V_1) that fulfills the aims of the usage conditions.

■ Set Filled Gas Pressure (P_1)

Ensure $P_1 \geq (1/\text{Max. compression ratio}) \times P_3$ must still be satisfied.

(See pages 10 and 11 for the maximum compression ratios of the individual series)

$$P_1 = \frac{273 + \text{Minimum temperature (Tmin)}}{273 + \text{Maximum temperature (Tmax)}} \times (0.8 \sim 0.9) \times P_2$$

■ Set Allowable Pressure (P_3)

(Pressure at System Temperature Increase of t_2)

■ Calculate Necessary Gas Volume (V_1)

$$V_1 = \frac{V_a (t_2 - t_1) (\beta - 3\alpha) (P_2/P_1)}{1 - (P_2/P_3)}$$

Convert the value to the absolute pressure in the calculation if the accumulator only has to support a pressure of 1 MPa or less.
[Absolute Pressure = Gauge Pressure + 0.1013 (MPa)]

Description of Symbols Used

V_1 : Necessary Gas Volume	ℓ
V_a : Total Amount of Fluid in Pipes (at t_1)	ℓ
P_1 : Filled Gas Pressure	MPa
P_2 : System Pressure at Temperature t_1	MPa
P_3 : System Pressure at Temperature t_2	MPa
t_1 : Initial System Temperature	°C
t_2 : Increased System Temperature	°C
α : Coefficient of Linear Expansion of Piping	1/°C
β : Coefficient of Volume Expansion of Fluid	1/°C

2. Select the Model Code of the accumulator

Select an accumulator from the appropriate series that satisfies Necessary Gas Volume (V_1) \leq Gas Volume and the Maximum Working Pressure being equal to or exceeding the System Pressure.

■ Example Calculation

Select an accumulator that can be used to raise the pressure of a closed-circuit steel pipe 16 meters long with a diameter of $\phi 125$ (Schedule 40) from 0.07 MPa at 20 °C to 0.4 MPa at 55 °C.

$$P_1 = P_2 \times 0.85 = (0.07 + 0.1013) \times 0.85 = 0.1456 \text{ MPa abs}$$

abs: Absolute Pressure

$$P_2 = 0.07 + 0.1013 = 0.1713 \text{ MPa abs}$$

$$P_3 = 0.4 + 0.1013 = 0.5013 \text{ MPa abs}$$

$$t_1 = 20 \text{ °C}$$

$$t_2 = 55 \text{ °C}$$

$$\alpha = 10 \times 10^{-6} \text{ 1/°C (Steel)}$$

$$\beta = 7.5 \times 10^{-4} \text{ 1/°C (Common Mineral Hydraulic Oil)}$$

$$V_a = 125.88 \times 1600 = 201408 \text{ cm}^3 = 201.41 \text{ ℓ}$$

$$V_1 = \frac{201.41 \times (55 - 20) \times (7.5 \times 10^{-4} - 3 \times 10 \times 10^{-6}) \times (0.1713/0.1456)}{1 - (0.1713/0.5013)} = 9.06 \text{ ℓ}$$

Bore Area of $\phi 125$ (Schedule 40) Steel Pipe
Outside Diameter of Steel Pipe: 139.8 mm
Thickness: 6.6 mm
Area = $\pi/4 \times (13.98 - 0.66 \times 2)^2 = 125.88 \text{ cm}^2$

The accumulator AL210-10-30 (gas volume: 10 ℓ) or AT18M-10-30 (gas volume: 10 ℓ) would be the most appropriate.

24. Attached Documents

The appropriate documents [**Accumulator Selection Request**] and [**Volume Calculation Sheet**] can be found on following pages.

Please photocopy any pages you require.

	Page
Accumulator Selection Request	68
Volume Calculation Sheet	
① Accumulator for Energy Accumulation	69
② Accumulator Used to Absorb Pulses	70
③ Accumulator Used to Absorb Impact	71
Unit Conversion Table	72

Accumulator Selection Request

✓ Check the applicable boxes. Please consult your nearest sales contact regarding anything you do not understand.

(To be completed by NOK)

Date Received

Branch, Agent, and Person in Charge

Company and Section	
Contact Person	Tel. Fax.
E-mail	
Equipment and Machinery, Installation Position	
Purpose of Accumulator	Specifications <input type="checkbox"/> Without <input type="checkbox"/> With *

*Write the Specification No. in the last column if anything specific is required.

1. Usage Conditions

Installation Site	<input type="checkbox"/> Indoors <input type="checkbox"/> Outdoors	Operating Time Required of Equipment	Hours/Days
Temperature Conditions	Fluid Temperature	~ °C	Normal Temperature °C
	Ambient Temperature	~ °C	Normal Temperature °C
Applicable Fluid	<input type="checkbox"/> Common Mineral Hydraulic Oil <input type="checkbox"/> Phosphoric Ester Operating Oil <input type="checkbox"/> Industrial Water <input type="checkbox"/> Other Types		

Direction of Accumulator Installation	<input type="checkbox"/> Vertical <input type="checkbox"/> Horizontal <input type="checkbox"/> Other
---------------------------------------	---

Consult your nearest sales contact for any cases where the accumulator will not be installed vertically with the gas side upward. If the accumulator is not installed vertically the possibility of "the necessary discharge not occurring" or "a shortened lifespan of the bladder" exist.

System Pressure	MPa	Maximum possible pressure applied to an accumulator in a circuit, and typically used to refer to the release pressure of a relief valve used with the equipment or machinery.
-----------------	-----	---

2. Application and Operating Conditions

① Energy Accumulation Only fill in the applicable columns.

Maximum Operating Pressure	MPa	Maximum pressure of accumulated fluid in the accumulator
Minimum Operating Pressure	MPa	Minimum pressure when fluid is discharged from the accumulator
Necessary Discharge Flow ΔV	ℓ	
Accumulation Period	s	Time required to accumulate ΔV in the accumulator
Discharge Period	s	Time required to discharge ΔV from the accumulator

② Pulse Absorption

Average Discharge Pressure	MPa	Average pressure of fluid discharged from pumps	
Target Ripple Factor	± %		
Type of Pump	<input type="checkbox"/> Plunger	Number	<input type="checkbox"/> Single-action
	<input type="checkbox"/> Diaphragm		<input type="checkbox"/> Double-action
	<input type="checkbox"/> Gear	No. of Teeth	pcs.
	<input type="checkbox"/> Vane	No. of Blades	pcs.
	<input type="checkbox"/> Other		
Pump Specifications	Discharge	ℓ/min	
	Rotations	rpm	

③ Impact Absorption

Normal Pressure	MPa	Pressure in pipes with no impact pressure
Allowable Impact Pressure	MPa	Maximum supported impact pressure. The higher the value the smaller in volume the accumulator can be.
Fluid Density	kg/m ³	Be careful with the units used. The unit used for water is in [1000].
Inside Pipe Diameter	mm	
Pipe Length	m	
Flow Rate	ℓ/min	
Flow Velocity	m/s	Not required if the "pipe diameter" and "flow rate" are provided.

<input type="checkbox"/> Thermal Expansion Compensation	<input type="checkbox"/> Equilibrium Action
<input type="checkbox"/> Transfer Barrier	<input type="checkbox"/> Gas Spring
<input type="checkbox"/> Leak Compensation	<input type="checkbox"/> Other

⇒ Consult your nearest sales contact

3. Specifications

Regulatory Test	<input type="checkbox"/> No Test Required (Eagle Industry Standard)	<input type="checkbox"/> High Pressure Gas Safety Law <input type="checkbox"/> Chinese Regulations <input type="checkbox"/> Class-2 Pressure Vessel <input type="checkbox"/> CE Mark <input type="checkbox"/> ASME <input type="checkbox"/> Other
	<input type="checkbox"/> Joint for Fluid Port Connecting	
Joint for Fluid Port Connecting	<input type="checkbox"/> Bushing	Connection Thread Rc
	<input type="checkbox"/> Flange	Connection Diameter A
		Type <input type="checkbox"/> Eagle Industry <input type="checkbox"/> F type <input type="checkbox"/> H type <input type="checkbox"/> D type <input type="checkbox"/> Other
Specifications Required by the Gas Side	<input type="checkbox"/> With TR Cap <input type="checkbox"/> Without TR Cap	(Standard Eagle Industry Specification)
	<input type="checkbox"/> Gas Control Valve	Safety Valve <input type="checkbox"/> Fuse Metal Type <input type="checkbox"/> Spring Type
		Pressure Gauge
		Max. Scale

4. Additional Specifications

Nameplate	<input type="checkbox"/> No Designation (Standard Eagle Industry Specification) <input type="checkbox"/> Designated Nameplate (Specifications Attached)	
Paint	<input type="checkbox"/> No Paint Required (Standard Eagle Industry Specification)	
	<input type="checkbox"/> Painted	<input type="checkbox"/> Painted According to Eagle Industry Standards Basecoat: One Coat of Synthetic Resin Topcoat: One Coat of Phthalic Acid Resin (JPMA No.B57-700)
	<input type="checkbox"/> Designated Paint (Specifications Attached)	
Internal Cleanliness	<input type="checkbox"/> Not Designated (Eagle Industry Standards NAS 10 class) <input type="checkbox"/> Designated NAS class	
Filled with Gas before Shipment	<input type="checkbox"/> Not Required <input type="checkbox"/> Required MPa at °C	
Other		
Specification No.		

(To be completed by NOK)	Result of Selection		Date of Response		Name and Department	
	Model Code					
	Product Code		×		units	
	Recommended Filled Gas Pressure		MPa	at		°C

Volume Calculation Sheet

① Accumulator for Energy Accumulation

(To be completed by NOK)

Data

Name and Section

Equipment and Machinery,
Installation Position

Set Conditions of Use

Applicable Fluid			
Temperature Conditions	Fluid Temperature	~	°C Normal Temperature °C
	Ambient Temperature	~	°C Normal Temperature °C
System Pressure	Pmax	MPa	Maximum possible pressure applied to an accumulator in a circuit, and typically used to refer to the release pressure of a relief valve with the equipment or machinery.
Maximum Operating Pressure	P3	MPa	Maximum pressure of accumulated fluid in the accumulator
Minimum Operating Pressure	P2	MPa	Minimum pressure when fluid is discharged from the accumulator
Average Operating Pressure	Pm	MPa	$Pm = (P3 + P2) / 2$
Necessary Discharge Flow	ΔV	ℓ	Total amount of fluid required for piston (actuator) operation
Accumulation Period	Δt_m	s	Time required to accumulate ΔV in the accumulator
Discharge Period	Δt_n	s	Time required to discharge ΔV from the accumulator

Calculate Necessary Gas Volume V1

Convert the value to the absolute pressure for use in calculation if the accumulator is used at 1 MPa or less. [Absolute Pressure (MPa) = Gauge Pressure + 0.1013]

■ Set Filled Gas Pressure (P1) Set the pressure according to either ① or ②. $P1 \geq (1/\text{Max. compression ratio}) \times P3$ must still be satisfied. (See pages 10 and 11 for the maximum compression ratios of the individual series)

① If no change in temperature takes place: $P1 = (0.8 \sim 0.9) \times P2 = 0.85 \times \quad = \quad \text{MPa}$

② If the temperature changes: $P1 = \frac{273 + T_{min}}{273 + T_{max}} \times (0.8 \sim 0.9) \times P2 = \frac{273 + \quad}{273 + \quad} \times 0.85 \times \quad = \quad \text{MPa}$

■ Set Polytropic Indices

Set the indices from the [List of Polytropic Indices] on page 60.

When Accumulated (m) ... Pm , Δt_m ;
When Discharged (n) ... Pm , Δt_n ;

■ Calculate Necessary Gas Volume for Accumulator (V1)

$$V_1 = \Delta V \times \frac{P_2^{\frac{1}{n}} \cdot P_3^{\frac{1}{m}}}{P_1^{\frac{1}{m}} \left(P_3^{\frac{1}{n}} - P_2^{\frac{1}{n}} \right)} = \quad \times \frac{\frac{1}{\quad} \times \frac{1}{\quad}}{\frac{1}{\quad} \times \left(\frac{1}{\quad} - \frac{1}{\quad} \right)} = \quad \ell$$

Verify Necessary Discharge Flow Qmax

$Q_{max} = \Delta V \times 60 / \Delta t_n = \quad \times 60 \div \quad = \quad \ell/\text{min}$

Select a NOK Accumulator Model

Select a model that satisfies " $V_1 \leq \text{Accumulator Gas Volume}$ " from the individual series listed on pages 12 to 31

Select an accumulator with which the necessary discharge flow Q_{max} will not exceed the maximum discharge flow. Select the AT series if the bladder for the 10 ℓ or larger accumulator is replaced from the gas side.

- Select the series according to the relevant Pmax, V1, Qmax. [Model Code of Selected Accumulator] [Gas Volume]
- Set the rubber material to according to the fluid used and temperature. ; ℓ
- Set the wetted specification to according to the fluid used.
- Set the joint for fluid port connecting and specifications required by the gas side.

No. of Necessary Accumulators (V_1 ; ℓ /Accumulator Gas Volume; ℓ /unit) [Rounded to the nearest whole number] = units

Verify the Discharge Flow ΔV_u of the Selected Accumulator

$$\Delta V_u = \text{Gas Volume} \times \frac{P_1^{\frac{1}{m}} \left(P_3^{\frac{1}{n}} - P_2^{\frac{1}{n}} \right)}{P_2^{\frac{1}{n}} \cdot P_3^{\frac{1}{m}}} = \quad \times \frac{\frac{1}{\quad} \times \left(\frac{1}{\quad} - \frac{1}{\quad} \right)}{\frac{1}{\quad} \times \frac{1}{\quad}} = \quad \ell \quad (\Delta V_u \geq \Delta V)$$

Volume Calculation Sheet

② Accumulator Used to Absorb Pulses

(To be completed by NOK)

Data

Name and Section

Equipment and Machinery, Installation Position

Set Conditions of Use

Applicable Fluid			
Temperature Conditions	Fluid Temperature	~	°C Normal Temperature °C
	Ambient Temperature	~	°C Normal Temperature °C

System Pressure	Pmax	MPa	Maximum possible pressure applied to an accumulator in a circuit, and typically used to refer to the release pressure of a relief valve with the equipment or machinery.
Average Discharge Pressure	Pm	MPa	The average pressure of fluid discharged from a pump, etc.
Target Ripple Factor		%	
Type of Pump	<input type="checkbox"/> Plunger	Number	<input type="checkbox"/> Single-action
	<input type="checkbox"/> Diaphragm		<input type="checkbox"/> Double-action
	<input type="checkbox"/> Gear	No. of Teeth	pcs.
	<input type="checkbox"/> Vane	No. of Blades	pcs.
	<input type="checkbox"/> Other		
Pump Specifications	Discharge	ℓ/min	
	Rotations	rpm	

[Constant K₁ for Each Individual Type of Pump]

Type of Pump	Number	K ₁	
		Single-action	Double-action
Plunger Diaphragm	1	0.60	0.25
	2	0.25	0.15
	3	0.13	0.06
	4	0.10	0.06
	5	0.06	0.02
	6	0.06	
	7 or more	0.02	
Gear and Vane		0.06	

Calculate Necessary Gas Volume V₁

Convert the value to the absolute pressure for use in calculation if the accumulator is used at 1 MPa or less. [Absolute Pressure (MPa) = Gauge Pressure + 0.1013]

■ Set Constant (K₁) that will Vary with the Type of Pump Set the constant from the list of [Constant K₁ for Each Individual Type of Pump] from above.

■ Set Filled Gas Pressure (P₁) Set the pressure according to either ① or ②. P₁ ≥ (1/Max. compression ratio) × P₃ must still be satisfied. (See pages 10 and 11 for the maximum compression ratios of the individual series)

① If no change in temperature takes place: P₁ = (0.6~0.8) × P_m = 0.7 × = MPa

② If the temperature changes: P₁ = $\frac{273+T_{min}}{273+T_{max}} \times (0.6\sim 0.8) \times P_m$ = $\frac{273 + \text{}}{273 + \text{}} \times 0.7 \times \text{}$ = MPa

■ Calculate Discharge (q) per Pump Rotation q = Discharge/Rotations = ÷ = ℓ/Rotation

■ Set Polytropic Indices (n) Calculate the value using n = 1.41 (nitrogen gas)

■ Calculate Maximum Target Line Pressure (P₃) P₃ = (1 + Ripple Factor/100) × P_m = (1 + /100) × = MPa

■ Calculate Necessary Gas Volume (V₁) for Accumulator

$$V_1 = \frac{q \cdot K_1 \cdot \left(\frac{P_m}{P_1}\right)^{\frac{1}{n}}}{1 - \left(\frac{P_m}{P_3}\right)^{\frac{1}{n}}} = \frac{\text{} \times \text{} \times \left(\frac{\text{}}{\text{}}\right)^{\frac{1}{1.41}}}{1 - \left(\frac{\text{}}{\text{}}\right)^{\frac{1}{1.41}}} = \text{} \ell$$

Select a NOK Accumulator Model

Select a model that satisfies "V₁ ≤ Accumulator Gas Volume" from the individual series listed on pages 12 to 31

Select the AT series if the bladder for the 10 ℓ or larger accumulator is replaced from the gas side.

- Select the series according to the relevant P_{max}, V₁.
- Set the rubber material to according to the fluid used and temperature.
- Set the wetted specification to according to the fluid used.
- Set the joint for fluid port connecting and specifications required by the gas side.

[Model Code of Selected Accumulator] [Gas Volume] ℓ

No. of Necessary Accumulators (V₁; ℓ/Accumulator Gas Volume; ℓ/unit) [Rounded to the nearest whole number] = units

Volume Calculation Sheet

③ Accumulator Used to Absorb Impact

(To be completed by NOK)

Data

Name and Section

Equipment and Machinery,
Installation Position

Set Conditions of Use

Applicable Fluid			
Temperature Conditions	Fluid Temperature	~	°C Normal Temperature °C
	Ambient Temperature	~	°C Normal Temperature °C
System Pressure	P _{max}	MPa	Maximum possible pressure applied to an accumulator in a circuit, and typically used to refer to the release pressure of a relief valve with the equipment or machinery.
Normal Pressure	P _A	MPa	The pressure within a pipe with no impact pressure.
Allowable Impact Pressure	P _B	MPa	Maximum supported impact pressure. The higher the value the smaller in volume the accumulator can be. The value is generally set to be 110% of the normal pressure. (P ₃ =11.0×1.1=12.1MPa)
Fluid Density	ρ	kg/m ³	Be careful with the units used. The unit used for water is in [1000].
Inside Pipe Diameter	d	mm	
Pipe Length	L	m	
Flow Rate	Q	ℓ/min	
Flow Velocity	v	m/s	Not required if the "pipe diameter" and "flow rate" are provided.

Calculate Necessary Gas Volume V₁

Convert the value to the absolute pressure for use in calculation if the accumulator is used at 1 MPa or less. [Absolute Pressure (MPa) = Gauge Pressure + 0.1013]

■ Calculate Fluid Mass (W) within the Line $W = \frac{\pi}{4} \cdot d^2 \cdot L \cdot \rho \cdot 10^{-6} = \frac{\pi}{4} \times \quad^2 \times \quad \times \quad \times 10^{-6} = \quad \text{kg}$

■ Calculate Flow Velocity (v) $v = 21.23 \times Q / d^2 = 21.23 \times \quad \div \quad^2 = \quad \text{m/s}$

■ Set Filled Gas Pressure (P₁) Set the pressure according to either ① or ②. P₁ ≥ (1/Max. compression ratio) × P₃ must still be satisfied. (See pages 10 and 11 for the maximum compression ratios of the individual series)

① If no change in temperature takes place: P₁ = (0.8~0.9) × P_A = 0.9 × \quad = \quad MPa

② If the temperature changes: P₁ = $\frac{273+T_{min}}{273+T_{max}} \times (0.8\sim 0.9) \times P_A = \frac{273 + \quad}{273 + \quad} \times 0.9 \times \quad = \quad$ MPa

■ Set Polytropic Indices (n) Calculate the value using n = 1.41 (nitrogen gas)

■ Calculate Maximum Supported Impact Pressure (P_B) P_B = 1.1 × P_A = 1.1 × \quad = \quad MPa

■ Calculate Accumulator Gas Volume (V_A) when Pressure is P_A

$$V_A = \frac{W \cdot v^2 \cdot (n - 1)}{200 \cdot P_A \times \left(\left(\frac{P_B}{P_A} \right)^{\frac{n-1}{n}} - 1 \right)} = \frac{\quad \times \quad^2 \times (1.41-1)}{200 \times \quad \times \left(\left(\frac{\quad}{\quad} \right)^{\frac{1.41-1}{1.41}} - 1 \right)} = \quad \ell$$

■ Calculate Necessary Gas Volume (V₁) for Accumulator $V_1 = V_A \times \frac{P_A}{P_1} = \quad \times \quad = \quad \ell$

Select a NOK Accumulator Model

Select a model that satisfies "V₁ ≤ Accumulator Gas Volume" from the individual series listed on pages 12 to 31

Select the AT series if the bladder for the 10 ℓ or larger accumulator is replaced from the gas side.

- Select the series \quad according to the relevant P_{max}, V₁. [Model Code of Selected Accumulator] [Gas Volume]
- Set the rubber material to \quad according to the fluid used and temperature. \quad ℓ
- Set the wetted specification to \quad according to the fluid used.
- Set the joint for fluid port connecting and specifications required by the gas side.

No. of Necessary Accumulators (V₁; \quad ℓ/Accumulator Gas Volume; \quad ℓ/unit) [Rounded to the nearest whole number] = \quad units

Conversion Tables for Main SI Units

The units within the thick frames represent SI units.

Length	m	in
	1 2.54×10^{-2}	39.37 1

Volume	m ³	ℓ	in ³	U.S.gal.	U.K.gal.
	1×10^{-3}	1	61.0271	0.26419	0.2200
	1	1×10^3	61027.1	264.19	220.0
	1.64×10^{-5}	0.01639	1	0.00433	0.0036
	3.79×10^{-3}	3.78543	231	1	0.8327
	4.55×10^{-3}	4.54596	277.413	1.2010	1

Mass	kg	lb
	1 0.45359	2.20462 1

Force	N	dyn	kgf
	1	1×10^5	1.01972×10^{-1}
	1×10^{-5}	1	1.01972×10^{-6}
	9.80665	9.80665×10^5	1

Pressure	Pa	MPa	kgf/cm ²	bar	psi
	1	1×10^{-6}	1.0197×10^{-5}	1×10^{-5}	1.4504×10^{-4}
	1×10^6	1	1.0197×10	1 × 10	1.4504×10^2
	9.80665×10^4	9.80665×10^{-2}	1	9.80665×10^{-1}	1.4223×10
	1×10^5	1×10^{-1}	1.0197	1	1.4504×10
	6894.757	6.8948×10^{-3}	7.0307×10^{-2}	6.8948×10^{-2}	1

Stress	Pa or N/m ²	MPa or N/mm ²	kgf/mm ²	kgf/cm ²
	1	1×10^{-6}	1.0197×10^{-7}	1.0197×10^{-5}
	1×10^6	1	1.0197×10^{-1}	1.0197×10
	9.80665×10^6	9.8067	1	1×10^2
	9.80665×10^4	9.8067×10^{-2}	1×10^{-2}	1

Process Energy Cal.	J	kW · h	kgf · m	kcal
	1	2.7778×10^{-7}	1.0197×10^{-1}	2.3889×10^{-4}
	3.6×10^6	1	3.6710×10^5	8.6000×10^2
	9.8067	2.7241×10^{-6}	1	2.3427×10^{-3}
	4.1861×10^3	1.1628×10^{-3}	4.2686×10^2	1

Power (Rate of Production, Motive Power) Heat Flow	W	kgf · m/s	PS	kcal/h
	1	1.0197×10^{-1}	1.3596×10^{-3}	8.6000×10^{-1}
	9.8067	1	1.3333×10^{-2}	8.4337
	7.355×10^2	7.5 × 10	1	6.3253×10^2
	1.1628	1.1857×10^{-1}	1.5810×10^{-3}	1

Viscosity	Pa·s	cP	P
	1	1×10^3	1×10
	1×10^{-3}	1	1×10^{-2}
	1×10^{-1}	1×10^2	1

Kinematic Viscosity	m^2/s	cSt	St
	1	1×10^6	1×10^4
	1×10^{-6}	1	1×10^{-2}
	1×10^{-4}	1×10^2	1

Thermal Conductivity	$W/(m \cdot K)$	$kcal/(h \cdot m \cdot ^\circ C)$
	1	8.6000×10^{-1}
	1.1628	1

Heat Transfer Coefficient	$W/(m^2 \cdot K)$	$kcal/(h \cdot m^2 \cdot ^\circ C)$
	1	8.6000×10^{-1}
	1.1628	1

Specific Heat	$J/(kg \cdot K)$	$kcal/(kg \cdot ^\circ C)$ $cal/(g \cdot ^\circ C)$
	1	2.3889×10^{-4}
	4.1861×10^3	1

Temperature Conversion Table

Temperature	$^\circ C$	$^\circ F$	$^\circ C$	$^\circ F$
	-40	- 40	+ 80	+176
	-20	- 4	+100	+212
	0	+ 32	+120	+248
	+20	+ 68	+140	+284
	+40	+104	+160	+320
	+60	+140	+180	+356
$^\circ C = \frac{5}{9} \times (^\circ F - 32)$		$^\circ F = \frac{9}{5} \times ^\circ C + 32$		



Eagle Industry Co., Ltd. Printed in Japan

AI Sales Department Marketing & Sales Division

1-12-15, Shiba-Daimon, Minato-ku, Tokyo, Japan. Zipcord 105-8587.

<http://www.ekk.co.jp/eng/>

(NOK GROUP)

The contents are subject to change without notice.

All compatibility data, application information, design & material information and technical data in this catalogue are compiled as a reference material to make a basic packing selection.

A selected standard design from this catalogue may not conform to the actual use of an application, due to unknown factors in the application.

Please confirm the actual compatibility of a selected product with your application before using it.