



● Cat. No. 040E · 11-2021

PACKINGS

HYDRAULIC SEALING SYSTEMS



PACKINGS

HYDRAULIC SEALING SYSTEMS

Everything starts with the packing.

Industrial equipment is facing a new innovation with remarkably developing mechatronics and remarkably advancing factory automation. Among other things, the performance of NOK's packing is dramatically improving in the field of actuation and the control of hydraulic and pneumatic equipment.

NOK has been advancing its unique research on rubber material, resin material and lip shape that determine the sealing performance of packing, and since 1960, NOK has been improving and reforming the rubber material "Iron rubber", developing it as the standard material for packing. This material can be said to be an ideal packing-dedicated polyurethane elastomer developed considering the balance of the physical property and being examined from every angle. NOK has also been positively developing materials such as nitrile rubber, fluorine rubber, hydrogenated nitrile rubber, and silicone rubber, and at the same time, has been developing and improving engineering plastic materials such as polytetrafluoroethylene resin and polyamide resin by making full use of NOK's unique compounding technique,

NOK
PACKINGS

thus always providing “one step ahead” materials and meeting every need of the customers. In the fields requiring technology high enough to claim “more than anything else, the quality of the sealing equipment shows the industrial level of that country”, NOK has continued to achieve unshaken performance for more than half a century.

NOK has been performing its unique in-house research, and also collaborating with NOK’s group companies overseas, Freudenberg (Germany), and Freudenberg-NOK(USA), thus performing close technological exchange, exchanging information on market trends, and providing cutting-edge world technology.

Based on this performance, NOK is also performing research and development on new products in the new fields of electronics, nuclear power, and high polymer chemistry, and also in the fields of chemitronics, optronics, and biotechnology, looking ahead to the future.

———— Various know-how cultivated over a long period of time in this way are gaining high reliability from a wide variety of world industrial fields. In the future, to meet the users’ increasing highly diversified needs, NOK will focus on the development of seal related products such as next-generation packing and engineering plastics, to further improve our technology.



Before using the packing

1. Storage Notes

When storing packings :

1. Do not open the packaging unnecessarily. "Dust" may stick to the packing or scratch it.
2. Avoid exposure to direct sunlight and store in a cool place.
Ultraviolet light and humidity may promote deterioration and dimensional change of rubber and resin material.
3. When storing products already unpacked, be careful that foreign materials do not stick or become embedded.
Store them in their original condition, in tightly sealed polyamide to prevent dimensional change resulting from humidity.
4. Do not replace packings near any heat source such as a boiler, stove, etc. Heat may deteriorate the material.
5. Do not place packings near electric motors or equipment generating ozone.
6. Avoid hanging packings with a nail, wire or suspending them with a string as this may cause deformation and scratches on the top end of the lip.
7. Sometimes, color changes or white powder appears on the surface of packings (blooming phenomenon).
This will not affect the function of the packing.
8. Rareflon rings of combination seals may be easily scratched if dropped or impacted by an external force.
Handle with care.

2. Storage Period of Packings

The following table shows the storage period of packings.
Use the storage period as a guide when storing.

Product	Material	Storage period
Rubber Material Products	Iron rubber* (PUR)	10 years
	Nitrile rubber (NBR)	10 years
	Hydrogenated nitrile rubber (H-NBR)	10 years
	Silicon rubber (VMQ)	20 years
	Fluoro rubber (FKM)	20 years
Rubber Baked Products	Nitrile rubber (NBR)	10 years
	Fluoro rubber (FKM)	10 years
Resin	Rareflon* (PTFE)	20 years
	Polyamide (PA)	20 years
	Resin fiber polyester	20 years
	Fabric reinforced phenolic (—)	20 years

*"Iron Rubber" and "Rareflon" are trade registered trademarks of NOK CORPORATION.

A registered trademarks of NOK CORPORATION	General name
Iron rubber	Polyurethane elastomer
Rareflon	Polytetrafluoroethylene resin

- The storage periods shown above are applicable to products sealed in standard packing and stored in a cool dry place away from direct sunlight.
- Dimensional changes due to moisture absorption of polyamide resin are not covered since it would depend greatly on the storage environment.
- The indicated storage periods do not account for rust formation on the metal parts of bonded seal products, since rust is largely influenced by the storage environment.
- Before using a packing that has been kept in storage for an extended period of time, check that it is free from rust.

- All compatibility data, application information, design & material information and technical data in this catalogue are compiled as reference material to make a basic packing selection.
A selected standard design from this catalogue may not conform to the actual use of an application, due to unknown factors of the application.
Please confirm the actual compatibility of a selected product with your application before using it.

- The contents are subject to change without notice.

The packing described in this catalog is not designed and manufactured to be suitable for medical devices. Do not use this packing for medical devices touching bodily fluids or body tissues.

HYDRAULIC SEALING SYSTEMS

CONTENTS

A	WHAT ARE NOK HYDRAULIC SEALING SYSTEMS	7 ~ 12	A
B	SELECTING, TYPES, AND FEATURES	13 ~ 32	B
C	TYPES AND FEATURES OF NOK PACKINGS	33 ~ 38	C
D	APPLICATION EXAMPLES OF NOK PACKINGS	39 ~ 56	D
E	DIMENSION TABLES FOR NOK PACKINGS	57 ~ 226	E
F	HANDLING AND INSTALLATION OF NOK PACKINGS	227 ~ 236	F
G	WHEN LEAKAGE OCCURS	237 ~ 250	G
H	TECHNICAL DATA	251 ~ 270	H
I	REFERENCE MATERIAL	271 ~ 303	I

A

WHAT ARE NOK HYDRAULIC SEALING SYSTEMS?

What are hydraulic sealing systems? —————	8
What are lip packings? —————	9
What are squeeze packings? —	9
How do packings seal? —————	10
Lubrication characteristics —	11

A. WHAT ARE NOK HYDRAULIC SEALING SYSTEMS?

Hydraulic Sealing Systems

are general terms describing sealing systems (seals) used for moving parts (usually with reciprocal movement) of hydraulic equipment. Different types of seals may be combined, depending on the application.

Different types of seals are classified...

below according to the application, form and material. Lip packings are most frequently used for reciprocal moving parts. An application example for a hydraulic cylinder is shown in Fig. A-1.

Clasofocation of Sealing Equipment

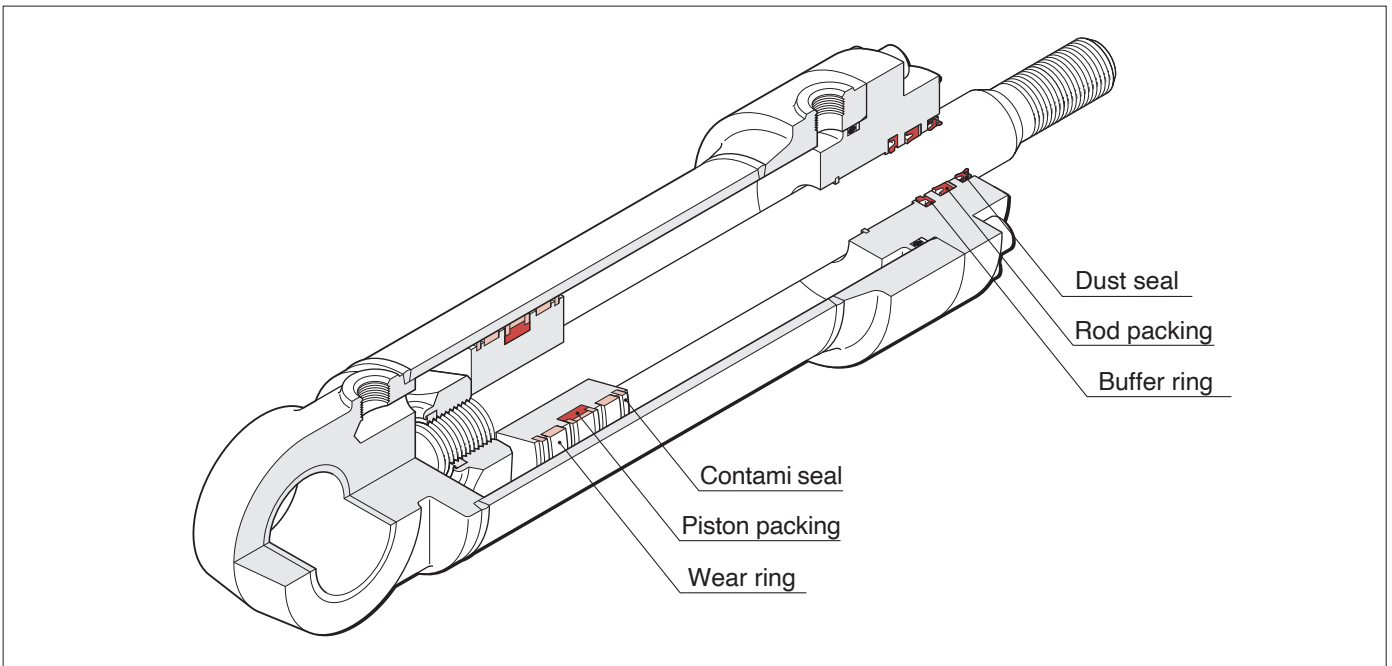
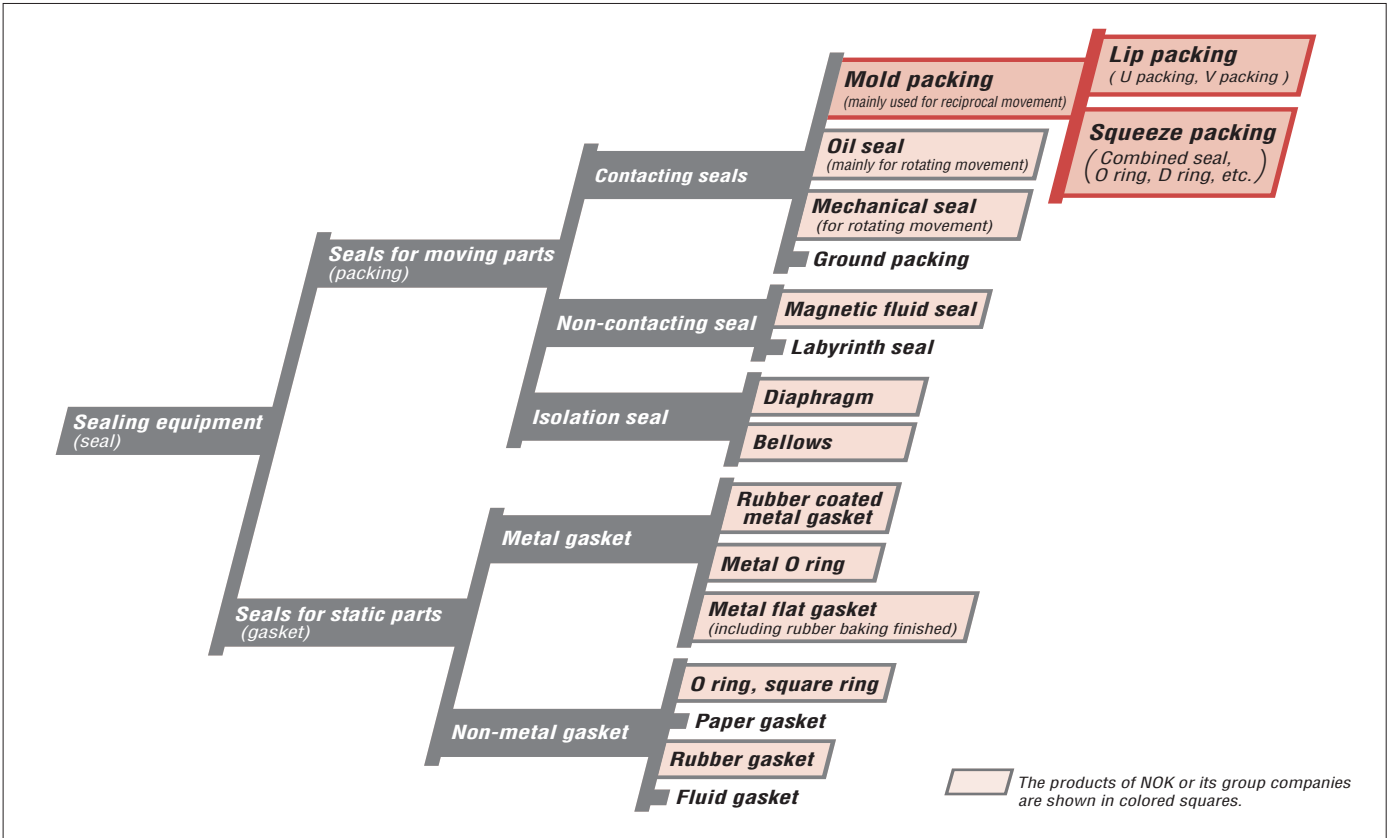

〈Fig. A-1〉 Application example for hydraulic cylinder

For effective application, hydraulic sealing systems should combine various sealing devices most appropriate for specific operating conditions and usage.

■ What are lip packings?

As its name suggests, a U packing is a general term describing a packing with a U-shaped groove as shown in **Fig. A-2**. This packing has an inner lip “A” and outer lip “B”.

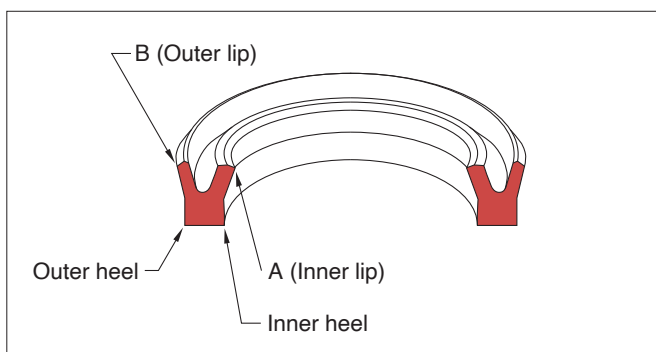

〈Fig. A-2〉 U packing

Fig. A-3 shows a U packing deformed by interference when fitted into the installation groove, which makes the lip contact with the rod. When fluid pressure (oil pressure) is added, the heel of the packing becomes deformed so the complete sliding surface is intact with the rod surface. The condition of contacting pressure distribution of the lip and heel is closely related with the sealing characteristics of the packing.

The relationship between sealing characteristics and contacting pressure distribution is described on **page A-4**.

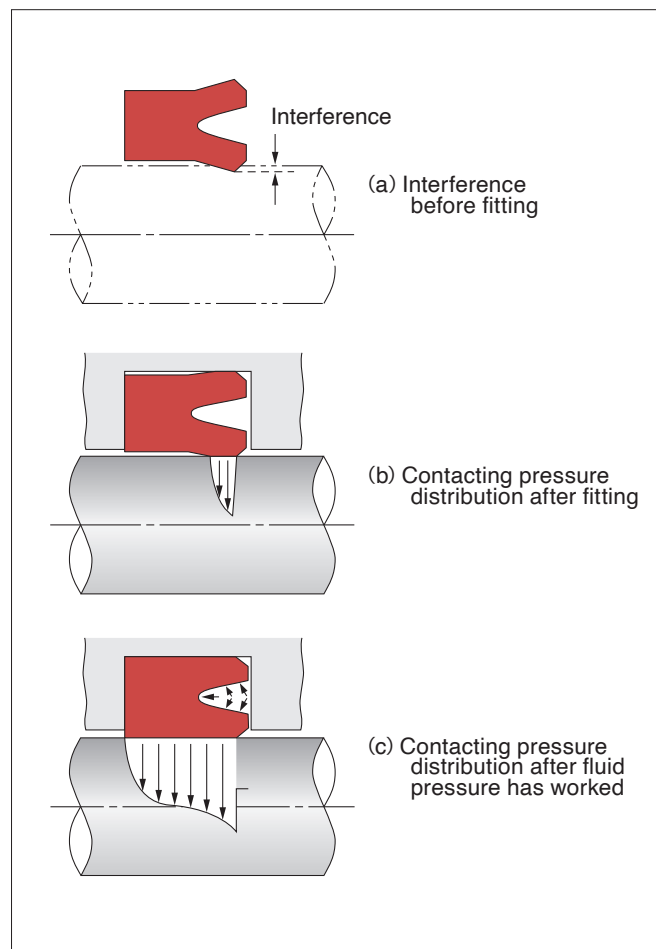

〈Fig. A-3〉 Contacting pressure distribution of U packing

■ What are squeeze packings?

This type of packing applies a rubber-like elastic object onto the sealed surface.

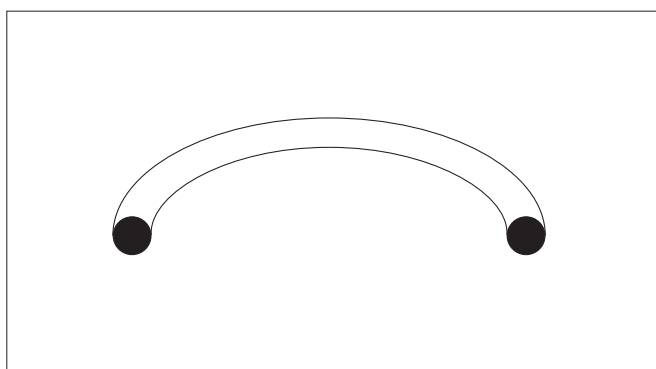

〈Fig. A-4〉 O ring

An O-ring (**Fig. A-4**) with an O-shaped profile is a typical squeeze packing. Significant pressure on the sealing surface is required to compress and deform the profile for sealing. For this reason, significant frictional resistance and high-sliding frictional heat is created resulting in a short life of the packing. To reduce sliding frictional resistance and frictional heat, the compression and deformation ratio of the O-ring should be decreased, which will, however, reduce the sealing ability.

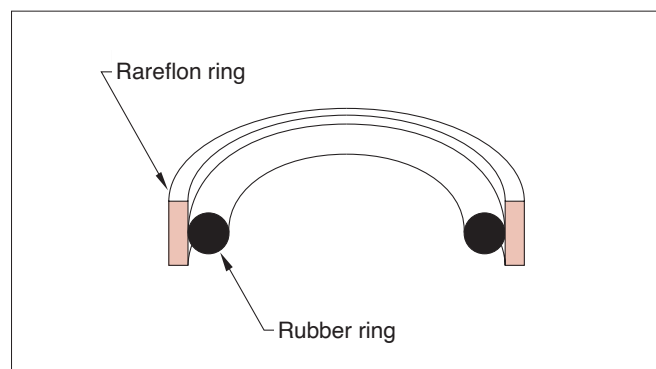

〈Fig. A-5〉 Example of combined seal

To decrease friction, a combined seal (called a SP seal) has been developed with low-friction rareflon (PTFE) on the sliding surface (**Fig. A-5**).

Compared to the lip packing, the combined seal has a lower sealing ability but offers lower sliding resistance. Because of these characteristics, this seal is mainly used as a piston packing for hydraulic cylinders.

How do packings seal?

By what means do packings for reciprocal movement seal hydraulic fluid? A U packing serves as a good example to illustrate sealing capability.

As shown in Fig. A-6, when the rod moves to the right, the U packing is contacting with the rod under pressure distribution created by the peak pressure ($P_{1 \max}$) that is higher than the inner pressure (P_1). Thickness of the fluid/oil passing through the packing becomes thinner as the absolute value of the maximum contacting pressure gradient of the hydraulic pressure of the pressure distribution $|dp/dx|_{\max,P}$ becomes greater.

Conversely, when the rod moves to the left by the inner pressure (P_2) on the U packing (Fig. A-7), the thickness of the fluid/oil passing through the packing depends on absolute value of the maximum contacting pressure gradient of the atmospheric pressure $|dp/dx|_{\max,M}$.

To reduce friction, a fluid/oil film on the sliding surface of the packing is necessary. NOK designs packings with well-balanced contacting pressure distribution to form optimum fluid/oil film on the sliding surface.

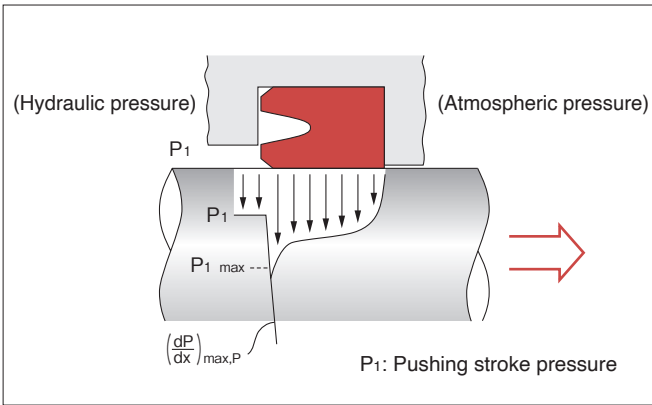

(Fig. A-6) Contacting pressure distribution (pushing stroke)

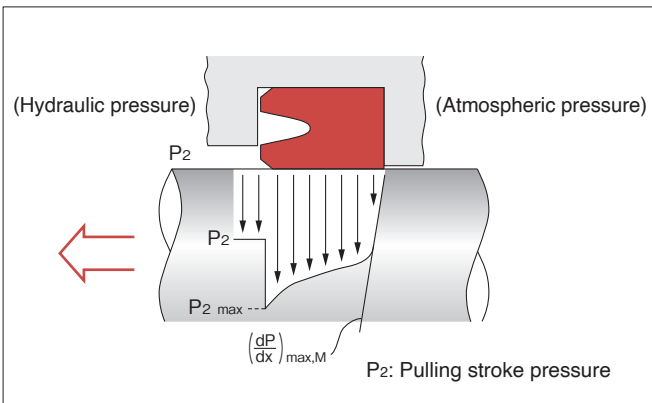

(Fig. A-7) Contacting pressure distribution (pulling stroke)

The minimum oil film thickness of the sliding surface depends on the maximum contacting pressure gradient, speed, and oil viscosity, and can be determined from the formula (1) below.

$$h = \sqrt{\frac{8\mu U}{9 |dp/dx|_{\max}}} \dots\dots\dots (1)$$

μ : Oil viscosity (Pa · s)

U : Speed (m/s)

$|dp/dx|_{\max}$: Absolute value of the maximum contacting pressure gradient (Pa/m)

In the case of a hydraulic cylinder, the thickness of the fluid/oil film created at the pushing stroke (when the rod extends) (h_P) and at the pulling stroke (when the rod compresses) (h_M) can be determined respectively by the formula (2) and (3).

$$h_P = \sqrt{\frac{8\mu U_P}{9 |dp/dx|_{\max,P}}} \dots\dots\dots (2)$$

$$h_M = \sqrt{\frac{8\mu U_M}{9 |dp/dx|_{\max,M}}} \dots\dots\dots (3)$$

U_P : Speed of the pushing stroke (m/s)

U_M : Speed of the pulling stroke (m/s)

$|dp/dx|_{\max,P}$: Absolute value of the maximum contacting pressure gradient of hydraulic pressure at the pushing stroke (Pa/m)

$|dp/dx|_{\max,M}$: Absolute value of the maximum contacting pressure gradient of atmospheric pressure at the pulling stroke (Pa/m)

Therefore, if the speed of both the pushing and pulling stroke is the same ($U_P=U_M$), $h_P \leq h_M$ is the condition for sealing and the packing satisfying the formula below

$$|dp/dx|_{\max,P} \geq |dp/dx|_{\max,M}$$

can be regarded to have a good sealing performance.

■ Lubrication characteristics

One of the most important features of a packing for reciprocal movement is to have low friction on the sliding surface to assure long life.

To reduce friction, proper lubricant (oil film) is necessary for the sliding surface of the packing for reciprocal movement. How do lubrication characteristics change according to operating conditions?

To understand globally the lubricating requirements of a packing's sliding surface, it is necessary to know dynamic friction characteristics when pressure, speed and fluid oil viscosity effecting the surface have changed.

An example of a U packing for a hydraulic cylinder rod helps explain this. The relationship between non-dimensional characteristics value G , that is determined by the form of U packings and its operating condition and the friction coefficient f , is determined in **Fig. A-8**. The range where the friction coefficient has a positive gradient is described as fluid lubrication in the lubrication theory. Within this range, the rod and the packing are in contact with each other through oil film, assuring a long packing life without wearing, even if a relative reciprocal movement occurs.

Within the range where the coefficient (f) has a negative gradient, the oil film between the packing and the rod is destroyed. This range is called the non-fluid lubrication area.

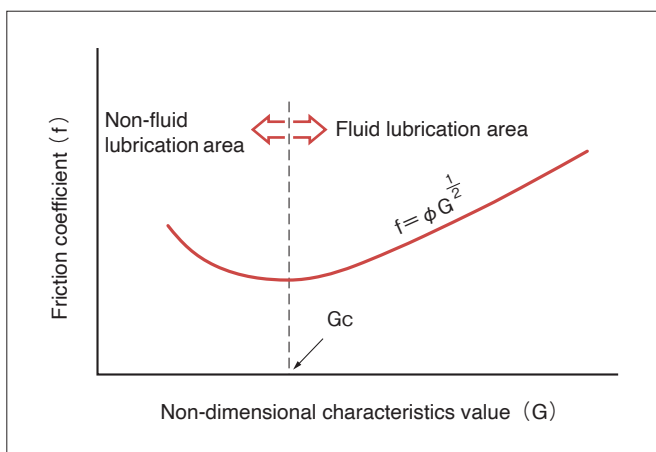

〈Fig. A-8〉 Example of non-dimensional characteristics graph (U packing)

Where,

- f : Friction coefficient
- ϕ : Constant that is determined by the condition of oil film
- G : Non-dimensional characteristics value ($= \mu LU/Pr$)
- Pr : Compression force of packing (N)
- μ : Viscosity of fluid oil (Pa·s)
- L : Circumference length of the shaft (m)
- U : Speed (m/s)

Switching point G_c of the non-dimensional characteristics value where the fluid lubrication area shifts to the non-fluid lubrication area varies depending on the maximum contacting pressure gradient of the packing and the surface roughness of the rod and can be obtained by the formula (4) below.

$$G_c = \frac{9}{8\pi} \left(\frac{b}{p} \right) \left| \frac{dp}{dx} \right|_{\max} \left(\frac{Rz}{b} \right)^2 \dots\dots (4)$$

Where,

- b : Contacting width of the packing (m)
- p : Average contacting pressure of the packing (Pa)
- Rz : Maximum surface roughness of the rod (m)

Note: The surface roughness notation in this catalogue conforms to JIS B 0601 : 2001.

About compression force and extension force

The forces created by the rod or piston packings that are fitted on the mounting groove and in contact with the contacting surface (the surface of the rod or the inner surface of the cylinder) is called compression force and extension force, respectively.

The sealing ability of packings for reciprocal movement depends on the maximum contacting pressure gradient of the pushing and pulling stroke. Therefore, the values of the compression and extension force are not sufficient to judge the sealing ability of a packing for reciprocal movement.

