

WR TYPE WEAR RING (FOR U TYPE PACKINGS)

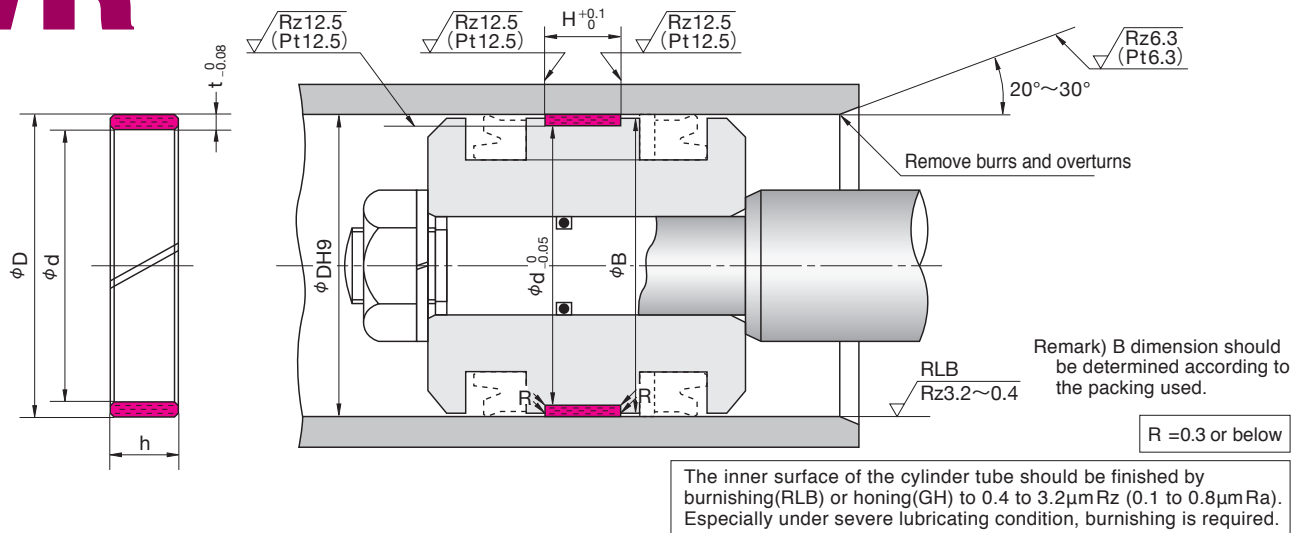

●The roughness is JIS B 0601 : 2001.
When regulation length cannot be kept, apply Pt.

Nominal Number	Nominal Size of Wear Ring, and Housing dimensions					NOK Part Number
	d	D	h	t	H	
WR 18	14	18	8	2	8	GW0241P0
19.2	15.2	19.2				GW0242P0
20	16	20				GW0243P0
22	18	22				GW0244P0
24	20	24				GW0245P0
25	21	25				GW0246P0
26	22	26				GW0247P0
28	24	28				GW0248P0
30	26	30				GW0249P0
31	27	31				GW0250P0
31.5	27.5	31.5	10	10	GW0251P0	
33	29	33			GW0252P0	
35	31	35			GW0253P0	
35.4	31.4	35.4			GW0254P0	
35.5	31.5	35.5			GW0255P0	
38	34	38			GW0256P0	
40	36	40			GW0257P0	
41	37	41			GW0258P0	
43	38	43			GW0259P0	
44.5	39.5	44.5			GW0260P0	
45	40	45	15	15	GW0261P0	
50	45	50			GW0006P1	
51.5	46.5	51.5			GW0263P0	
55	50	55			GW0264P0	
56	51	56			GW0010P1	
60	55	60			GW0012P1	
61	56	61			GW0267P0	
63	58	63			GW0268P0	
65	60	65			GW0269P0	
66	61	66			GW0270P0	
69	64	69	20	20	GW0271P0	
70	65	70			GW0019P1	
71	66	71			GW0192P1	
75	70	75			GW0021P1	
76	71	76			GW0746P0	
80	75	80			GW0027P1	

E DIMENSION WR

WR TYPE

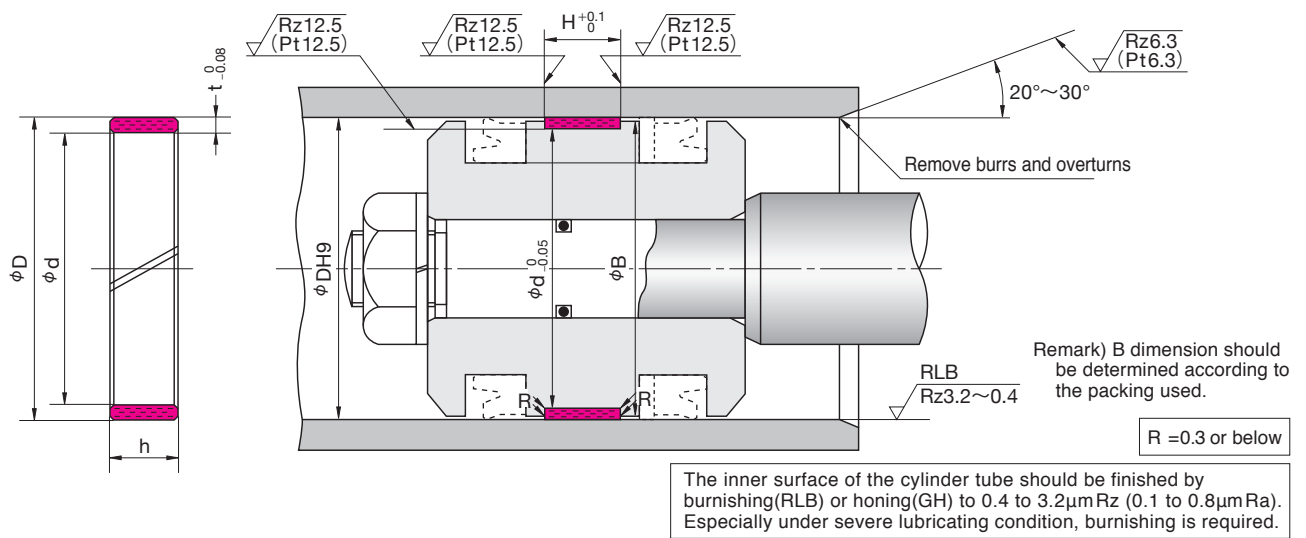

●The roughness is JIS B 0601 : 2001.
When regulation length cannot be kept, apply Pt.

Nominal Number	Nominal Size of Wear Ring, and Housing dimensions					NOK Part Number	
	d	D	h	t	H		
WR 85	79	85	25	3	25	GW0030P1	
90	84	90				GW0036P1	
95	89	95				GW0167P1	
100	94	100				GW0041P3	
105	99	105				GW0278P0	
110	104	110				GW0051P1	
112	106	112	30	30	GW0280P0		
115	109	115			GW0055P2		
120	114	120			GW0059P1		
125	119	125			GW0283P0		
130	123	130			GW0065P1		
132	125	132			GW0285P0		
140	133	140	35	3.5	35	GW0075P1	
150	143	150			40	GW0086P1	
157	150	157			40	GW0287P0	
160	153	160			40	GW0093P2	
165	157	165			45	45	GW0289P0
170	162	170					GW0290P0
180	172	180	GW0104P1				
185	177	185	GW0292P0				
190	182	190	GW0293P0				
200	192	200	GW0109P1				
205	197	205	50	4	50	GW0181P1	
210	202	210			50	GW0296P0	
220	212	220			50	GW0297P0	
224	216	224			50	GW0298P0	
225	217	225			55	GW0115P1	
230	222	230			55	GW0300P0	
240	232	240	60	60	60	GW0301P0	
250	242	250			60	GW0122P1	
260	252	260			60	GW0303P0	
270	262	270			60	GW0304P0	
275	267	275			60	GW0305P0	
290	282	290			70	70	70
297	289	297	70	GW0308P0			
300	292	300	70	GW0309P0			
312	304	312	70	GW0310P0			
332	324	332	70	GW0311P0			

E DIMENSION WR

WR TYPE WEAR RING (FOR PACKINGS OF SPG AND SPGW TYPE)

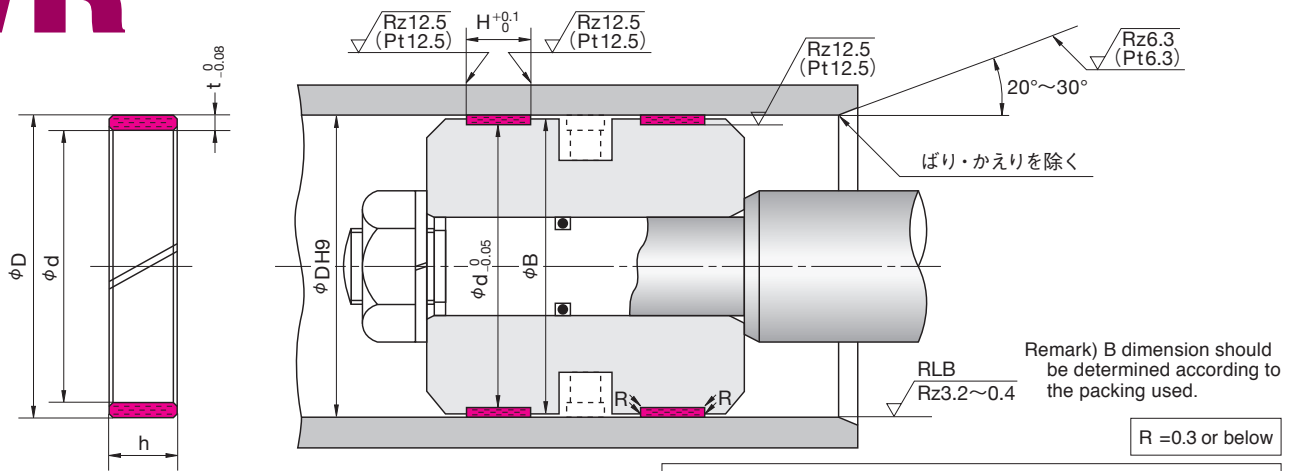

The inner surface of the cylinder tube should be finished by burnishing (RLB) or honing (GH) to 0.4 to 3.2 μm Rz (0.1 to 0.8 μm Ra). Especially under severe lubricating condition, burnishing is required.

●The roughness is JIS B 0601 : 2001.
When regulation length cannot be kept, apply Pt.

Nominal Number	Nominal Size of Wear Ring, and Housing dimensions					NOK Part Number			
	d	D	h	t	H				
WR 30W	26	30	8	2	8	GW0249P0			
31.5W	27.5	31.5				GW0251P0			
32W	28	32				GW0314P0			
35W	31	35				GW0315P0			
35.5W	31.5	35.5				GW0316P0			
40W	36	40				GW0317P0			
45W	40	45				GW0318P0			
50W	45	50				GW0279P0			
55W	50	55				GW0319P0			
56W	51	56				GW0320P0			
60W	55	60	10	2.5	10	GW0321P0			
63W	58	63				GW0322P0			
65W	60	65				GW0323P0			
69W	64	69				GW0324P0			
70W	65	70				GW0018P1			
71W	66	71				GW0326P0			
75W	70	75				GW0327P0			
80W	75	80				GW0025P1			
85W	79	85				GW0329P0			
90W	84	90				GW0330P0			
95W	89	95	15	3	15	GW0331P0			
100W	94	100				GW0332P0			
108W	102	108				GW0333P0			
110W	104	110				GW0334P0			
112W	106	112				GW0335P0			
120W	114	120				GW0336P0			
125W	119	125				GW0337P0			
130W	123	130				GW0338P0			
140W	133	140				GW0339P0			
150W	143	150				20	3.5	20	GW0340P0
160W	153	160	GW0341P0						
170W	162	170	GW0342P0						
180W	172	180	GW0343P0						
190W	182	190	GW0344P0						
200W	192	200	25	4	25				GW0345P0
204W	196	204							GW0346P0
210W	202	210							GW0347P0
224W	216	224							GW0348P0
225W	217	225							GW0349P0
230W	222	230				GW0350P0			
240W	232	240				30	4	30	GW0351P0
250W	242	250							GW0352P0

E DIMENSION WR