



O-RINGS

Globally Recognized World Class Quality

NOK Precision Precision Moldings & O-Rings Division acts as the base for our company's O-ring manufacturing operations, and by passing the strictest international quality assurance standard audits, it has helped us to earn recognition as an ISO 9001 compliant supplier.

Based on this "testament" to our excellence, we intend on taking steps toward achieving continuous quality improvements so that we can further solidify our reputation as a reliable and trustworthy supplier.

NOK Precision Molding & O-Rings Division: ISO 9001 certified (in October, 1998)



[NOK Precision Molding & O-Rings Division] 2089 Nagakusa, Aso City, Kumamoto Prefecture, JAPAN

NOK does not guarantee the accuracy of any data provided by third parties.

[Table of Contents]

O-RINGS

1.	Introduction	2	1
2.	Selecting O-Rings	6	2
3.	O-Ring Sealing Mechanisms	6	3
4.	Types of O-Rings	7	4
5.	Temperature Ranges and Sealing Medium of Standard Materials	8	5
6.	Standard Values and Actual Values for O-Ring Standard Materials	10	6
7.	O-Ring Design Standards	14	7
8.	O-Ring Usage Methods (Types of Grooves) and Precautions	16	8
9.	Chamfering Design for Holes and Shafts	18	9
10.	Precautions for Special Applications	18	10
11.	Precautions for O-Ring Installation	19	11
12.	Precautions for Storage, and Shelf Life	19	12
13.	JIS Dimension Identification Codes	20	13
14.	Le- μ 's: Low Friction(μ) Seals	20	14
15.	Dimension Tables for NOK Standard O-Rings	21	15
	JIS P Series	22	
	JIS G Series	30	
	NOK S Series	34	
	NOK SS Series	36	
	JIS V Series	37	
	AS568 (old ARP568) Series	38	
	Old JASO Thickness \varnothing 1.9 Series	46	
	Old JASO Thickness \varnothing 2.4 Series	48	
	Old JASO Thickness \varnothing 3.1 Series	50	
	Old JASO Thickness \varnothing 3.5 Series	52	
	ISO Equivalent General Industrial Series	54	
	NOK WEX Series (O-Ring series for water applications)	57	
	NOK Iron Rubber P, G Series	58	
	JIS Equivalent Backup Rings	60	
	NOK SP Coating O-Ring Series	64	
16.	O-Ring Surface Treatment Technology	65	16
17.	Joint O-Rings	65	17
18.	Chemical/Solvent Resistance Material "FP64"	66	18
19.	Klüber Lubricants for Sealing	67	19
20.	Reference Materials -Actual Data, Blooming, Swelling, Failure Mode Case Studies, Etc.-	68	20
21.	O-Ring Groove Dimensions for Standards with No Groove Indications	75	21
22.	O-Ring Dimension Quick Chart	83	22
	NOK Product Lineup	92	
	Appendix (Typical Tolerances and Dimensions/SI Unit Conversion Table)	94	



High-performance brand that contributes to the environment through low-friction technologies

1. Introduction

(1) Creating sealing function to keep Fluids or Pressure away

O-rings are the most typical sealing products generating compressive stress to have sealing function. Although synthetic rubber is widely used material to produce O-rings recently, when they were first introduced around the mid-19th century for sealing cylinders in steam engines, it is said that cast iron was used to produce such products. In later years, natural rubber with elastic properties would have been used to form such products, and after entering the 1940s, usage of synthetic rubber that we make use of today became the norm, thereby making it possible to seal a wide variety of fluids, such as air, water, gas, and oil.

As a notable example, such products were used in the hydraulic systems of aircraft during World War II, and the high reliability of these sealing products sparked their rapid adoption for use in applications involving general pneumatic and hydraulic equipment, and such use continues until today. While it goes without saying that proper usage and design are required in order to maintain high reliability, material selection and quality also play a critical role.

We, NOK, have established the Shonan R&D Center in order to further enhance our material technology capabilities that we have developed throughout our long and storied history. In the center, we can now engage in fundamental technological research that goes far beyond our past capabilities, and it has enabled us to establish a material development system that can meet the demands of our customers for an even wider range of applications and requirements.

Furthermore, at NOK, we engage in efforts from a global standpoint as we continue to expand our overseas presence. As part of such efforts, we have designated our Kumamoto Plant as our hub for O-ring production and as a "Model Factory," which enables us to create even better on-site production environments that allow us to strive for even further improvements in quality and consistency.

At NOK, our O-rings have already helped us to earn the trust of customers in a wide array of industrial sectors across the world, and through our constantly evolving material development technologies and our consistent production of reliable, high-quality O-rings, we hope to continue to meet the ever-changing and increasingly sophisticated requests of our customers.

[Types of Sealing Equipment]

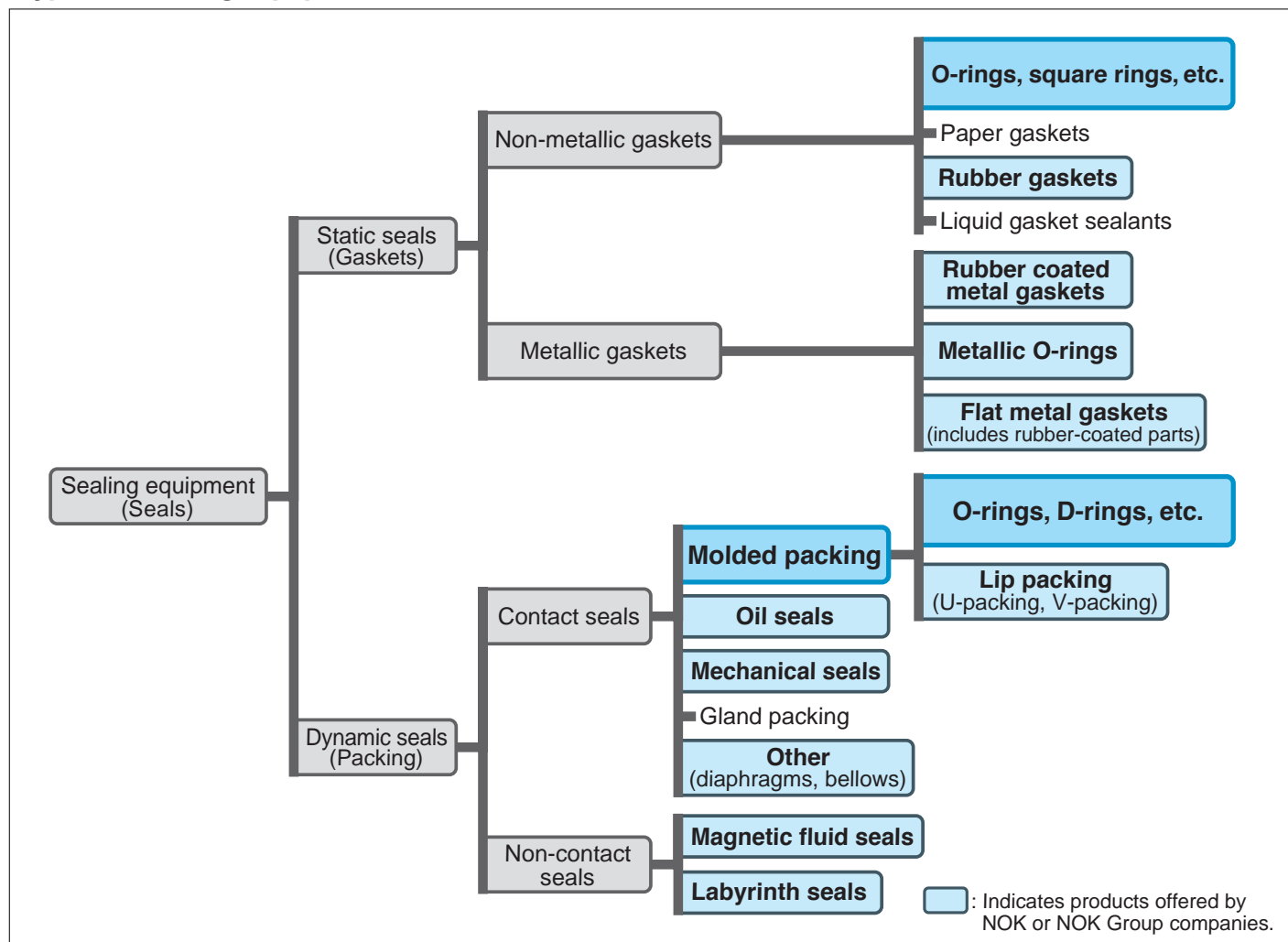

(2) Features of NOK O-Rings

a.) Vast range of materials offered (approx. 200 types)

We offer a vast range of materials that can meet your requests for a wide variety of applications. Just provide us with your usage conditions, and NOK is going to select the ideal material for you.

b.) Original materials based on NOK's proprietary compounding technologies and design

We use our own proprietary design to develop materials that satisfy JIS specifications.

Utilizing material engineering technologies to fully take advantage of the characteristics of polymers and chemicals, we strive to develop materials that can meet the needs of our valued customers.

c.) Fully-integrated quality control system (every process from the compounding/mixing stage is carried out at NOK)

NOK processes begin with receiving chemicals, polymers, and carbon materials.

NOK quality control processes also begin at this stage as we strictly manage the quality of such raw materials.

NOK production processes are carried out under our fully-integrated quality control system from raw material to finished product.

d.) Extensive testing and analysis capabilities based on our sophisticated testing facilities

In addition to material testing for standard physical properties, compression set, and oil immersion testing, our system enables us to conduct extensive in-house analysis of sealing performance.

Just provide us with your required usage conditions and testing conditions so that we can leverage our abundant wealth of experience and a wide array of testing facilities to better support you in your product development efforts.

e.) Globally Recognized World Class Quality

Our products have a proven track record that has been established over the years through use in the automotive, construction machine, agricultural machine, and general machinery industries, and by supplying such products, we contribute to the further development of industries and the continued evolution of manufacturing activities throughout the world.

(3) NOK O-Ring Production Process Flow *Excludes O-rings made from Iron Rubber (polyurethane elastomer)

Inspections are conducted at each individual process, and only those parts that pass inspections are allowed to proceed to the next process.

Lot numbers are used to ensure traceability for each individual process from the receiving of chemicals to product shipment.

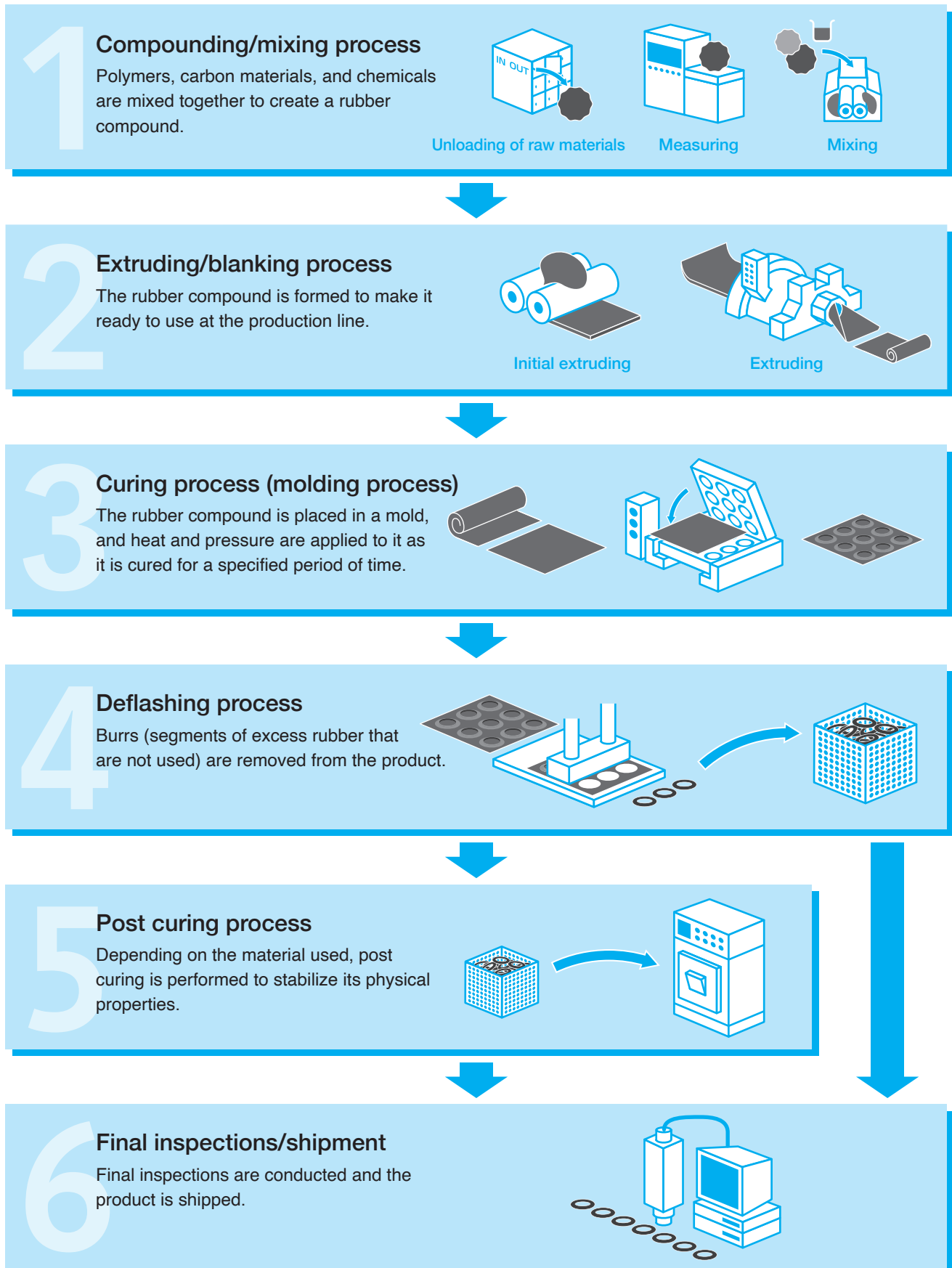

(4) O-Ring Design Related Terminology

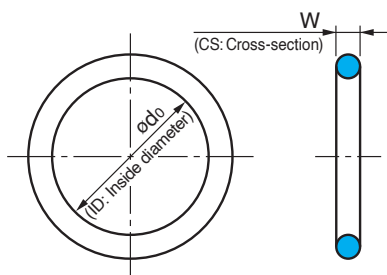

Fig. 1-1 O-Ring

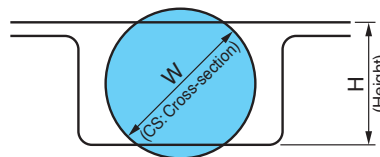

Fig. 1-2 How O-Rings Are Used

(1) O-Rings for Cylindrical Surfaces

Term	Calculation formula	Schematic
Compression value (mm)	$\sigma = W - H$	
Compression ratio (%)	$\frac{\sigma}{W} \times 100$	
Filling ratio (%)	$\frac{\pi/4 \times W^2}{G \times H} \times 100$	
Piston seal for cylindrical surfaces	$\frac{D_1 - d_0}{d_0} \times 100$	
Inside diameter (ID) elongation ratio (%)		
Rod seal for cylindrical surfaces	$\frac{d_0 + 2W - D_2}{d_0 + 2W} \times 100$	
Outside diameter (OD) interference ratio (%)		

(2) O-Rings for Flat Faces

Term	Calculation formula	Schematic
Compression value (mm)	$\sigma = W - H$	
Compression ratio (%)	$\frac{\sigma}{W} \times 100$	
Filling ratio (%)	$\frac{\pi/4 \times W^2}{G \times H} \times 100$	

2. Selecting O-Rings

2
3

An O-ring is a ring-shaped packing that has a round cross-section, and they are typically used by seating them in a groove and applying an adequate degree of compressive stress in order to seal a wide variety of fluids, such as oil, water, air, or gas.

Products can be designed for static or dynamic sealing, and unless an appropriate product is selected to match the usage conditions, this could result in such conditions as tearing, swelling, or compression cracking due to pressure. In order to ensure consistent sealing performance over long periods of time, it is necessary to select products with materials and dimensions that are suitable for the usage conditions.

When selecting a product, it is necessary to take into consideration the factors given in Table 1-1.

Table 1-1

Factor	Page	Purpose
a. Usage temperature	8	For material selection
b. Medium being sealed	9	
c. Degree of pressure	15	For selecting material hardness; determining if backup ring is necessary.
d. Usage method (static or dynamic)	22~59, 64	Dynamic: JIS P Series, Old JASO Series, WEX Series, NOK Iron Rubber P/G Series Static: JIS P/G/V Series, NOK S/SS Series, AS568 Series, Old JASO Series, ISO Equivalent Series, WEX Series, NOK Iron Rubber P/G Series, SP Coating O-Ring Series

Please consult with NOK if the factors shown to the left do not suffice.

3. O-Ring Sealing Mechanisms

(1) O-Ring Sealing Mechanisms

O-rings provide a sealing mechanism when the compressed O-ring exerts a reaction force to form a seal.

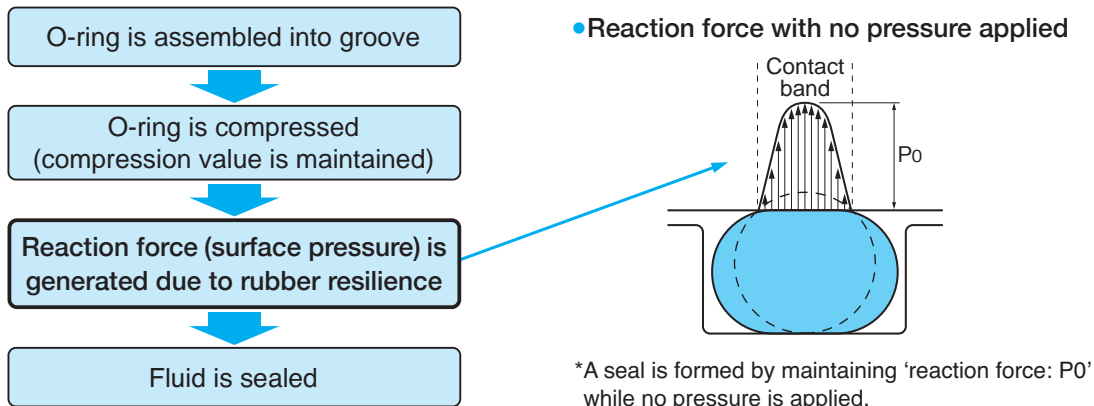

(2) Required Characteristics for O-Ring Materials

As the stress generated due to squeezing and compression of the O-ring causes it to provide a sealing function, one of the basic required characteristics is that the material maintains an adequate degree of stress within a range where abnormal deformation does not occur. It is also required that these basic characteristics are not lost during use. Of the materials that possess such characteristics, synthetic rubber is the best choice for such purposes. With that said, however, since it is not possible to fulfill all of these characteristics using just a single material, it is necessary to choose the right material depending on the specific application in which the product will be used.

NOK offers various types of materials that can meet a wide range of usage conditions.

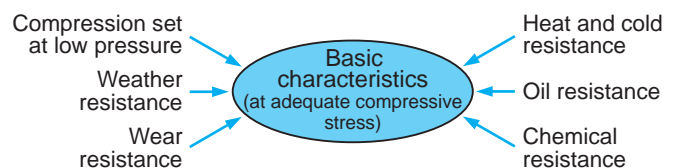



4. Types of O-Rings

The different types of standard NOK O-ring products are shown in Table 2-1.

NOK O-rings are offered in various dimensions as given for the following series of products: JIS P/G/V Series, ISO Equivalent Series, Old JASO, AS, NOK S/SS Series, and NOK Iron Rubber P/G Series.

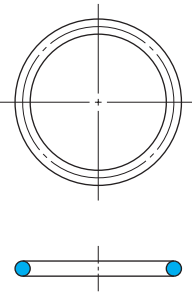
Table 2-1

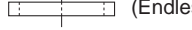
Application		For general machinery					For automobiles		For aircraft
Type	Standard	JIS B 2401-1	ISO equivalent (for general industrial use)	NOK Iron Rubber P, G Standard (JIS B 2401 compliant)	NOK S standard NOK SS standard	Old JASO F404		AS568 (old ARP568)	
 O-ring	Classification by material	JIS	Usage details	Material	Material	Material	JASO	Usage details	Material
		NBR-70-1	(Mineral oil resistance)	A305	U565	A305	F201	Class 1A	(General mineral oil resistance)
	NBR-90	(Mineral oil resistance)	—					—	
NBR-70-2	(Gasoline resistance)	Class 2	(Gasoline resistance)						
FKM-70	(Heat resistance)	Class 3	(Animal and vegetable oil resistance)						
FKM-90	(Heat resistance)	Class 4C	(Heat resistance)						
Class 4C**	(Heat resistance)	Class 4D	(Heat resistance)						
Classification by application	• P Series (dynamic/static)	Static	• P Series (dynamic/static)	• S Series* (static sealing at low pressure)	Thickness ø1.9 Series (old 1000 Series)	Thickness ø2.4 Series (old 2000 Series)	Thickness ø3.1 Series (old 3000 Series)	Thickness ø3.5 Series (old 3000 Series)	Static (old AN6227 is for dynamic sealing)
	• G Series (static)								
Shape and dimensions of O-ring installation groove	JIS B 2401-2 (dynamic/static) JIS B 2290 (vacuum flange)	—	JIS B 2401-2 (dynamic/static)	NOK S standard NOK SS standard	JASO F404		—		
Backup rings	Equivalent to JIS B 2401-4					—	—	—	
	T1	 (Spiral)							
	T2	 (Bias-cut)							
	T3	 (Endless)							

Note: *The NOK S/SS Series has been designed as a series that meets the demand for O-rings with particularly smaller diameter and thickness for use in compact hardware.

Note: The JIS standards for O-Ring use in aircraft related applications (W1516, W1517, W2006, W1537, and W1538) have already been abolished.

*Material H is the NOK material code used for H-NBR (hydrogenated nitrile rubber).

**Material 4C corresponds to JIS B 2401-2005.

[Reference]

An introduction on cross-section shapes that differ with those of O-rings are given in Table 2-2. Please consult with NOK for more details.

Table 2-2

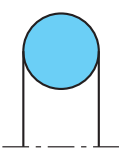
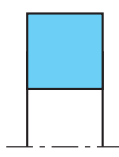
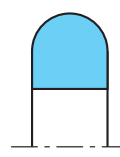
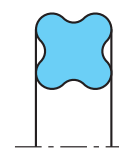
		O-ring	Square-ring	D-ring	X-ring
Shape					
Cylindrical surface	Reciprocating	○	—	◎	◎
	Static	○	—	—	—
Flat face static sealing		○	◎	—	—
Application		General use	Static sealing	Reciprocating	Low friction dynamic sealing
Characteristic		—	High reaction force and good sealing function	Shape for twisting resistance, small groove width	Twisting resistant, low friction

5. Temperature Ranges and Sealing Medium of

In order for an O-ring to properly function, it is necessary to select a material that is appropriate for the usage conditions. Please use Table 3-1 as a guide when selecting O-ring materials based on usage temperature and resistance to the sealing medium.

Table 3-1 Selecting Materials for NOK O-Rings

NOK O-ring Materials		Material code	Hardness (Duro-meter A)	Guide for usage temperature range *1 (°C)				Major usage examples	Application series	JIS, JASO
Material name (material code)	Characteristic			Numbers in parentheses () indicate max. values -50°C 0°C 100°C 200°C						
Nitrile rubber (NBR)	Widely used as a sealing material for various products, and it has the best balance of performance and workability.	A402	60	-26	100	(120)	General use			
		A122	70	-22	80	(100)	Use w/ fuel	P·G·JASO	JIS NBR-70-2/ JASO class 2	
		A305	70	-24	100	(120)	General use	P·G·V·JASO- AS·ISO·S·SS	JIS NBR-70-1/ JASO class 1A	
		A746	70	-25	100	(120)	Use w/ LPG			
		A908	70	-25	80	(100)	Use w/ fuel		JIS NBR-70-2 equivalent /JASO class 2 equivalent	
		A980	80	-48	80	(100)	Low temp. use			
		A105	90	-23	100	(120)	General use	P·G·AS	JIS NBR-90	
Ethylene propylene rubber (EPDM)	Possesses excellent ozone and heat resistant properties. Also having superior steam, cold, and LLC (coolant) resistance, etc.	E270	50	-43	130	(150)	Low μ (coefficient of friction) use w/ water			
		E622	60	-40	130	(150)	Low μ (coefficient of friction) use w/ water			
		E116	70	-49	130	(150)	Use w/ water (general), use w/ brake fluid	JASO	JIS EPDM-70 equivalent /JASO class 5	
		E575(violet)	70	-46	130	(150)	Use w/ water, chlorine resistance	WEX		
		E700	70	-48	130	(150)	Use w/ water	WEX		
		E340	80	-48	130	(150)	Use w/ brake fluid			
Silicone rubber (VMQ)	In addition to heat and cold resistance, excellent lubricant and water-resistant properties.	S532(dark blue)	60	-44	200	(220)	General use			
		S503(dark blue)	70	-48	200	(220)	General use	P·G·JASO	JIS class 4C equivalent /JASO class 4C	
		S740(red)	70	-48	200	(220)	Hydrolysis resistance			
		S811 (red)	70	-46	200	(220)	General use		JIS class 4C equivalent/ JASO class 4C equivalent	
Fluorosilicone rubber (FVMQ)	In addition to the properties of VMQ, superior fuel-resistant properties.	S924 (green)	70	-55	200	(220)	Use w/ fuel			
Hydrogenated nitrile rubber (HNBR)	Superior to NBR in terms of heat and oil resistance, mechanical strength, compression set resistance, and ozone resistance.	G636	60	-26	110	(130)	General use			
		G607	70	-22	110	(130)	General use		JIS HNBR-70 equivalent	
		G861	75	-23	110	(130)	Use w/ freon (R134a)			
		G859	80	-22	110	(130)	Use w/ freon (R134a)			
		G506	90	-24	110	(130)	General use		JIS HNBR-90 equivalent	
		G588	95	-21	110	(130)	High-pressure use			
Fluororubber (FKM)	Among the synthetic rubber materials, it possesses the best heat, oil, and fuel resistant properties.	F320	60	-16	200	(220)	General use			
		F201	70	-16	200	(220)	General use	P·G·V·JASO- AS·S·SS	JIS FKM-70/ JASO class 4D	
		FP29	70	-15	200	(220)	hot water resistance	WEX		
		FP739(brown)	70	-16	200	(220)	hot water resistance	WEX		
		F274	75	-16	200	(220)	Wear resistance			
		FL25	80	-30	200	(220)	low temp. use, use w/ fuel			
		FL68	80	-31	200	(220)	low temp. use, use w/ fuel			
		F753	80	-15	200	(220)	Wear resistance			
		F357	90	-15	200	(220)	Wear resistance			
Acrylic rubber (ACM)	Superior to NBR in terms of heat resistance, resistant to mineral oils.	T134	60	-20	130	(150)	low CS (compression set)			
		T222(brown)	70	-21	130	(150)	low CS (compression set)			
		T667	70	-21	130	(150)	low CS (compression set)			
		T767	70	-18	130	(150)	General use	JASO	JIS ACM-70 equivalent /JASO class 4E	
Chloroprene rubber (CR)	Exhibits excellent mechanical strength and flexural fatigue resistance, etc.	M352	70	-44	100	(120)	General use			
Butyl rubber (IIR)	The least amount of gas permeability Among the various rubber materials.	B383	75	-51	120	(140)	General use, gas permeation resistance			
Styrene-butadiene rubber (SBR)	Superior wear resistance and an excellent balance of workability and performance.	R189	70	-51	80	(100)	Use w/ brake fluid	JASO	JASO class 3	
Polyurethane rubber (AU)	High hardness, high elasticity, high mechanical strength, and excellent wear resistance.	U565	90	-35	80	(100)	High-pressure use			
		U801(milky white)	94	-35	80	(100)	High-pressure use	Iron Rubber		

***1 Usage temperatures**

Usage temperatures range can be affected by a variety of factors, such as sealing medium, usage conditions, and functional requirements. For more details, please consult with NOK.

Higher limit: These values have been determined by taking the results of air and heat aging testing into consideration.

The temperatures indicated within the parentheses () indicate heat resistance temperatures for temporary usage. Please avoid subjecting the product to such conditions during continuous, long-term usage.

Lower limit: TR₁₀ has been applied to determine these values. TR is an abbreviation for Temperature-Retraction as defined in JIS K 6261, and the values indicate deformation resilience at low temperatures, and they are roughly equivalent to the degree of recovery of rubber elasticity. TR₁₀ refers to the temperature at which 10% recovery from initial deformation is achieved, and it can be used as a guide for determining low temperature usage limits.

6. Standard Values and Actual Values for O-Ring

6

Table 4-1 Standard Values and Actual Values [The actual measurement values shown below are not guaranteed values.]

Test item	Type of material	NBR-70-1		NBR-90		NBR-70-2	
	Applicable NOK number	A305		A105		A122	
	Usage details	(For mineral oil resistance)		(For mineral oil resistance)		(For gasoline resistance)	
	(Standard values/actual values)	Standard values	Actual values	Standard values	Actual values	Standard values	Actual values
Standard physical properties	Hardness (durometer A)	70±5	71	90±5	91	70±5	71
	Tensile strength (MPa)	≥10	20.8	≥14	18.1	≥10	20.9
	Elongation (%)	≥250	340	≥100	150	≥200	420
	Tensile stress (MPa) (at 100% elongation)	≥2.5	4.5	—		≥2.5	4.3
Aging	Temp. and time	72 hours at 120°C		72 hours at 120°C		72 hours at 100°C	
	Change in hardness (points)	≤+10	+3	≤+10	+3	≤+10	+4
	Change in tensile strength (%)	≥-15	+2	≥-25	+10	≥-15	+4
	Change in elongation (%)	≥-45	-7	≥-55	-37	≥-40	-23
Compression set	Temp. and time	72 hours at 120°C		72 hours at 120°C		72 hours at 100°C	
	Compression set (%)	≤40	13	≤40	26	≤25	18
Oil resistance test 1	Temp. and time	72 hours at 120°C		72 hours at 120°C		72 hours at 23°C	
	Oil tested	Lubricant oil No.1		Lubricant oil No.1		Lubricant oil No.1	
	Change in hardness (points)	-5 - +8	±0	-5 - +8	+3	-8 - 0	-1
	Change in tensile strength (%)	≥-15	+2	≥-20	-13	≥-15	-4
	Change in elongation (%)	≥-40	-12	≥-40	-23	≥-25	-5
	Change in volume (%)	-8 - +5	-3.6	-8 - +5	-4.3	-3 - +5	+0.6
Oil resistance test 2	Temp. and time	72 hours at 120°C		72 hours at 120°C		72 hours at 23°C	
	Oil tested	Lubricant oil No.3		Lubricant oil No.3		Lubricant oil No.2	
	Change in hardness (points)	-15 - 0	-7	-10 - +5	-8	-20 - 0	-12
	Change in tensile strength (%)	≥-25	-11	≥-35	-13	≥-45	-32
	Change in elongation (%)	≥-35	-13	≥-35	-13	≥-45	-32
	Change in volume (%)	0 - +20	+11.8	0 - +20	+10.7	0 - +30	+24.3
Low temp. test	TR ₁₀ value (°C) at 50% elongation	≥-15	-24	≥-15	-23	≥-10	-22

The TR₁₀ value (abbreviation for Temperature-Retracton) indicates deformation resilience at low temperatures, and this is roughly equivalent to the degree of recovery of rubber elasticity based on the rubber material's properties.

Since O-rings function by rubber elasticity, it is possible to estimate the low temperature performance of that material by identifying this TR value. Furthermore, the value ₁₀ in TR₁₀ indicates that the temperature shown represents the temperature at which 10% recovery is achieved from initial deformation, and based on experiential knowledge, it is understood that temperatures in the vicinity of these values represent the low temperature limits of the O-ring.

Standard Materials

**Material class 4C corresponds to JIS B 2401-2005.

FKM-70		FKM-90		Class 4C**		JIS	Type of material Test item
F201		F940		S503		Applicable NOK number	
(For heat resistance)		(For heat resistance)		(For heat resistance)		Usage details	
Standard values	Actual values	Standard values	Actual values	Standard values	Actual values	(Standard values/ actual values)	
70±5	71	90±5	92	70±5	70	Hardness (durometer A)	Standard physical properties
≥10	14.2	≥10	17.0	≥3.4	6.1	Tensile strength (MPa)	
≥170	230	≥80	140	≥60	150	Elongation (%)	
≥2.0	4.1	—		—	4.9	Tensile stress (MPa) (at 100% elongation)	
72 hours at 230°C		72 hours at 230°C		24 hours at 230°C		Temp. and time	Aging
≤+5	-2	≤+5	±0	≤+10	+1	Change in hardness (points)	
≥-10	+2	≥-10	-5	≥-10	+12	Change in tensile strength (%)	
≥-25	-8	≥-25	+5	≥-25	-6	Change in elongation (%)	
72 hours at 200°C		72 hours at 200°C		22 hours at 175°C		Temp. and time	Compression set
≤40	21	≤40	12	≤30	10	Compression set (%)	
72 hours at 175°C		72 hours at 175°C		70 hours at 175°C		Temp. and time	Oil resistance test 1
Lubricant oil No.1		Lubricant oil No.1		Lubricant oil No.1		Oil tested	
-10 - +5	±0	-10 - +5	-2	-10 - +5	-5	Change in hardness (points)	
≥-20	+2	≥-20	+9	≥-20	+1	Change in tensile strength (%)	
≥-20	-4	≥-20	+3	≥-20	+2	Change in elongation (%)	
-5 - +5	±0.0	-5 ~ +5	+0.9	0 - +10	+4.5	Change in volume (%)	
72 hours at 175°C		72 hours at 175°C		—		Temp. and time	Oil resistance test 2
Lubricant oil No.3		Lubricant oil No.3		—		Oil tested	
-10 - +5	-2	-10 - +5	-1	—		Change in hardness (points)	
≥-20	-7	≥-20	+3	—		Change in tensile strength (%)	
≥-20	+9	≥-20	+4	—		Change in elongation (%)	
-5 - +5	+2.4	-5 - +5	+1.9	—		Change in volume (%)	
≥-10	-15	≥-10	-15	—	-48	TR ₁₀ value (°C) at 50% elongation	Low temp. test

Table 4-2 Standard Values and Actual Values [The actual measurement values shown below are not guaranteed values.]

Test item	Type of material	Class 3		Class 4E		Class 5	
	JIS	R189		T767		E116	
	Applicable NOK number	R189		T767		E116	
	Usage details	(For animal and vegetable oil resistance)		(For heat resistance)		(For coolant resistance)	
	(Standard values/actual values)	Standard values	Actual values	Standard values	Actual values	Standard values	Actual values
Standard physical properties	Hardness (durometer A)	70±5	73	70±5	73	70±5	72
	Tensile strength (MPa)	≥9.8	19.4	≥5.9	12.8	≥9.8	18.5
	Elongation (%)	≥150	240	≥100	180	≥150	210
	Tensile stress (MPa) (at 100% elongation)	≥2.7	6.1	—		>2.7	5.5
Aging	Temp. and time	70 hours at 100°C		70 hours at 150°C		70 hours at 120°C	
	Change in hardness (points)	≤+10	+2	≤+10	+2	<+10	+1
	Change in tensile strength (%)	≥-15	-6	≥-30	+2	<-20	-2
	Change in elongation (%)	≥-45	-9	≥-40	-7	<-40	-4
Compression set	Temp. and time	70 hours at 100°C		70 hours at 150°C		70 hours at 120°C	
	Compression set (%)	≤25	10	≤60	30	<40	5
Oil resistance test 1	Temp. and time	70 hours at 100°C		70 hours at 150°C		70 hours at 100°C	
	Oil tested	Brake fluid		Lubricant oil No.1		Coolant	
	Change in hardness (points)	-15-0	-3	-7-+10	-3	-5-+5	+1
	Change in tensile strength (%)	≥-40	-5	≥-30	+2	≥-30	-16
	Change in elongation (%)	≥-40	-11	≥-40	-7	≥-30	-6
	Change in volume (%)	0-+12	+2.5	-5-+5	-0.3	-5-+10	+1.2
Oil resistance test 2	Temp. and time	—		70 hours at 150°C		—	
	Oil tested	—		Lubricant oil No.3		—	
	Change in hardness (points)	—		-20-0	-13	—	
	Change in tensile strength (%)	—		≥-40	-15	—	
	Change in elongation (%)	—		≥-40	-9	—	
	Change in volume (%)	—		0-+30	+15.9	—	
Low temp. test	TR ₁₀ value(°C) at 50% elongation	—	-51	—	-18	—	-49

The TR₁₀ value (abbreviation for Temperature-Retracton) indicates deformation resilience at low temperatures, and this is roughly equivalent to the degree of recovery of rubber elasticity based on the rubber material's properties.

Since O-rings function by rubber elasticity, it is possible to estimate the low temperature performance of that material by identifying this TR value.

Furthermore, the value ₁₀ in TR₁₀ indicates that the temperature shown represents the temperature at which 10% recovery is achieved from initial deformation, and based on experiential knowledge, it is understood that temperatures in the vicinity of these values represent the low temperature limits of the O-ring.

*Material H refers to the NOK material code for hydrogenated nitrile rubber.

H*		NOK WEX Series				NOK Iron Rubber Series		JIS	Type of material
G607		E700	E575	FP29	FP739	U801		Applicable NOK number	
(For wear resistance)		(For use w/ water)		(For use w/ water)		(For pressure/wear resistance)		Usage details	
Standard values	Actual values	Actual values	Actual values	Actual values	Actual values	Actual values		(Standard values/ actual values)	
70±5	70	71	72	72	72	94		Hardness (durometer A)	
≥16.7	23.5	19.1	15.0	19.7	19.8	43.1		Tensile strength (MPa)	
≥150	240	210	200	320	300	550		Elongation (%)	
—		—	—	—	—	—		Tensile stress (MPa) (at 100% elongation)	
70 hours at 120°C		70 hours at 120°C		70 hours at 230°C		80°C 70h		Temp. and time	
<+10	+5	+2	+1	+2	+1	±0		Change in hardness (points)	
<-15	+4	-3	+15	+9	-4	+1		Change in tensile strength (%)	
<-40	-4	-8	+11	+1	+3	+2		Change in elongation (%)	
70 hours at 120°C		70 hours at 120°C		70 hours at 175°C		80°C 70h		Temp. and time	
<20	10	6	6	10	13	32		Compression set (%)	
70 hours at 120°C		70 hours at 100°C		70 hours at 100°C		80°C 70h		Temp. and time	
Lubricant oil No.1		Steam		Steam		Lubricant oil No.1		Oil tested	
-5 - +10	+5	+1	+1	±0	-2	±0		Change in hardness (points)	
≥-20	-4	-4	-11	-15	-7	±0		Change in tensile strength (%)	
≥-35	-10	±0	-2	+6	+6	-2		Change in elongation (%)	
-15 - +5	-5.2	+0.5	+0.4	+3.5	+2.9	-0.3		Change in volume (%)	
70 hours at 120°C		—	—	70 hours at 150°C		80°C 70h		Temp. and time	
Lubricant oil No.3		—	—	Water vapor		Lubricant oil No.3		Oil tested	
-10 - +10	+1	—	—	-3	±0	±0		Change in hardness (points)	
≥-30	+4	—	—	-18	-12	-3		Change in tensile strength (%)	
≥-30	-6	—	—	+8	+2	-4		Change in elongation (%)	
-10 - +10	+3.3	—	—	+4.4	+2.0	+5.4		Change in volume (%)	
—	-22	-48	-48	-16	-16	-29		TR ₁₀ value (°C) at 50% elongation	
								Low temp. test	

7. O-Ring Design Standards

Please refer to the following for the different concepts and dimensional standards related to proper O-ring usage.

(1) Concepts Related to O-Ring Functioning

Fig. 1-1 shows a graph that depicts the relationship between O-ring compression ratio and compression set. As shown in Fig. 1-1, O-rings made of rubber pose a risk of compression cracking when the ratio is 40% or higher. If the compression ratio becomes too low, there is a risk that leakage may occur.

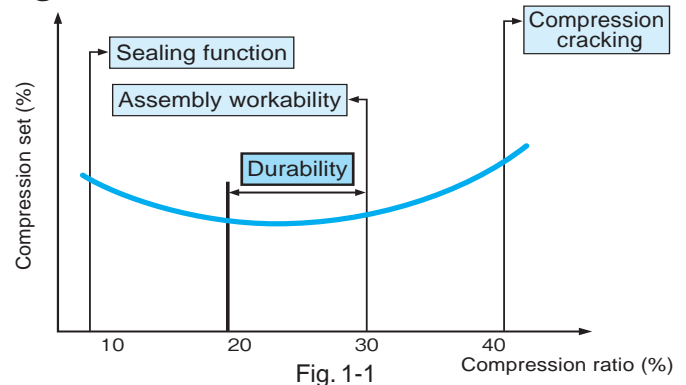

(2) Standards for Determining O-Ring Groove Dimensions

Table 5-1 shows the general NOK setting values. Please consult with NOK if your requirements are for dynamic sealing in low friction applications or if you have specialized specifications.

Table 5-1

Type	Cylindrical surface		Flat face	
	Piston seal	Rod seal	Internal pressure seal	External pressure seal
Schematic				
Compression ratio (%)	8 - 25		8 - 30	
Filling ratio (%)	Target median value of 75%, max. 90% or less			
Determining inside/outside diameter	Inside diameter elongation ratio [%] 0 - 5	Outside diameter elongation ratio [%] 0 - 3	Contacting wall on non-pressurized side Outside wall diameter = seal outside diameter	Inside wall diameter = seal inside diameter

(3) Selecting O-Ring Thickness

The relationship between O-ring thickness and compression set is shown in Fig. 1-2. As shown in the figure, when the compression ratio is fixed, compression set becomes lower as thickness becomes thicker, and based on this, it is possible to achieve stable sealing performance by selecting thicker O-rings. In particular, when selecting products for dynamic sealing, it is possible to prevent twisting by selecting a thicker item.

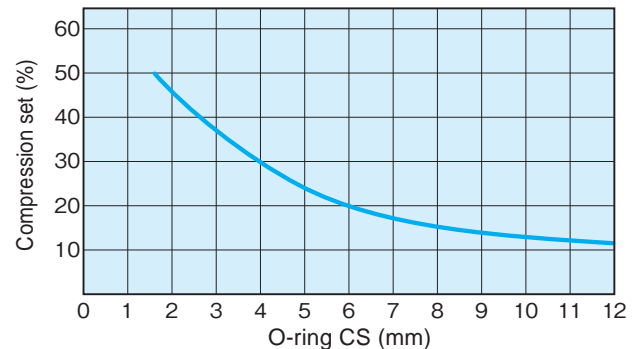

Fig. 1-2 Compression Ratio of 25% for A305 (exposed to air for 70 hours at 120°C)

(4) Surface Roughness of Groove

The surface roughness of the portions contacting the O-ring are indicated in Table 5-2. Please consult with NOK if you encounter any issues during design or product usage.

Table 5-1

*Rz: Max. roughness height

Hardware portion	Application	Type of pressure applied		Surface roughness	
				Ra	Rz
Groove side and bottom face	Static sealing	Without pulse	Flat face	3.2	12.5
			Cylindrical face	1.6	6.3
	Dynamic sealing	Using a backup ring	With pulse	1.6	6.3
			Not using a backup ring	0.8	3.2
Contacting face of O-ring seal portion	Static sealing	Without pulse	1.6	6.3	
		With pulse	0.8	3.2	
	Dynamic sealing	—	0.4	1.6	
Chamfered portion for O-ring installation	—	—	—	3.2	12.5

As surface roughness of the groove portions can impact the following, it will be necessary to control these factors.

- For dynamic sealing: Friction and wear resistance
- For static sealing: Secure sealing due to conforming (gripping) of rubber to the mating surface

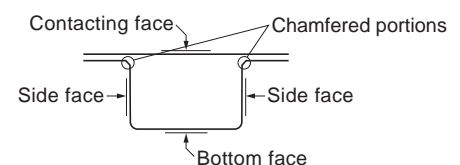

(5) Clearance Gaps and Extrusion

If an O-ring is pushed into a clearance gap within the groove due to sealing fluid pressure, and this further progresses to where heavy extrusion occurs, it will no longer be able to maintain its functionality.

Such extrusion is determined by fluid pressure, clearance, and rubber hardness. Please refer to Fig. 1-3 for an illustration of this relationship (for these values it is assumed that there is no groove deformation due to pressure; if there is a risk of deformation of the sealing surface due to pressure, clearance should be set to roughly 75% of these values).

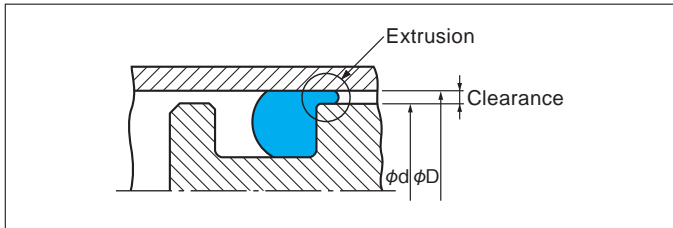

[Test conditions]

1. No backup rings are used.
2. Cylinder swelling due to fluid pressure is assumed to be 0.
3. For the results shown, the pressure cycle ranges from 0 to the indicated pressure, and testing has been performed for 100,000 cycles at 150 cycles/minute.

Note) For cases involving usage for cylindrical surfaces, it is necessary to take into consideration the effects of eccentricities, etc. Please consult with NOK when designing such applications.

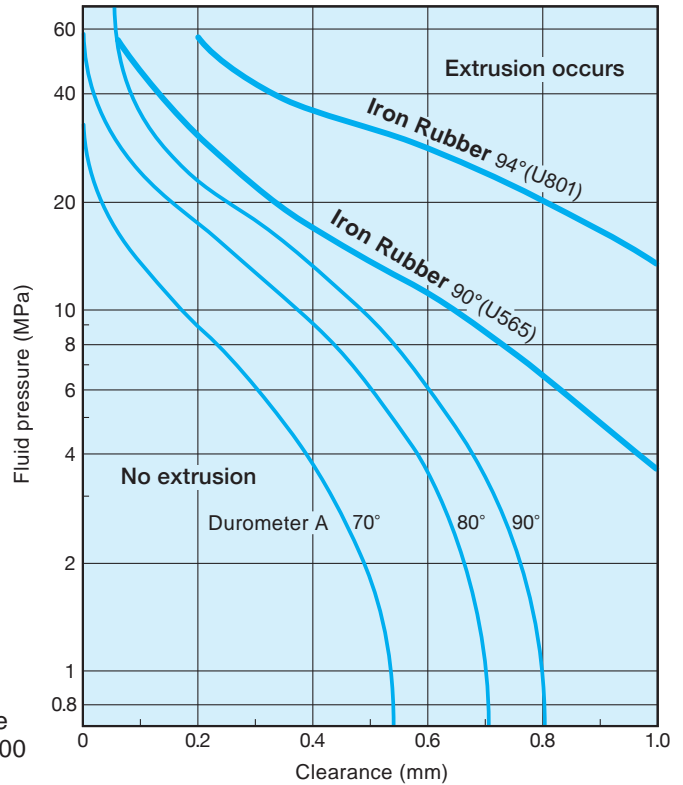

Fig. 1-3 O-Ring Extrusion Limits

[Countermeasures to Prevent Extrusion (About the Usage of Backup Rings)]

If pressure or clearance exceeds the limits shown in Fig. 1-3, please consider to use backup rings. In case where pressure is being applied from both directions, install backup rings on both sides, and in case where pressure is being applied from one direction, install it on the side opposite from which pressure is being applied. Backup rings come in 3 types of shapes, namely, endless type, bias-cut type, and spiral type, and although the endless type is the most effective from a usage standpoint, the bias-cut type is convenient due to its easy installation. Some typical materials used for backup rings and their characteristics are shown in Table 5-3.

For more detailed O-ring and groove dimensions, please refer to pages 22 through 59.
 For more detailed backup ring dimensions, please refer to pages 60 through 63.
 *Only 10FF is available for NOK standard parts.

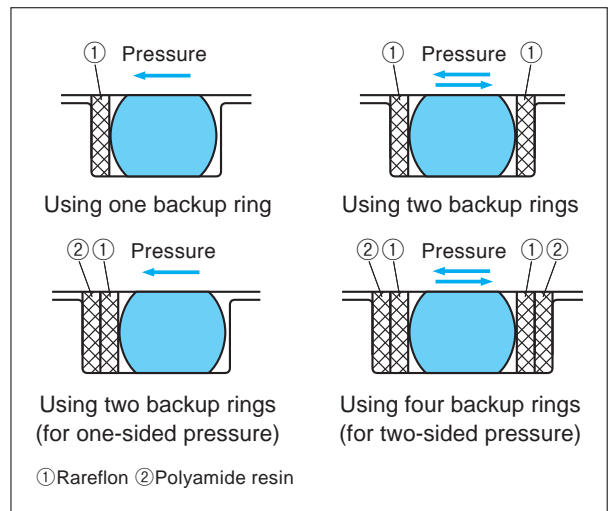

Table 5-3

Material name	NOK material code	Characteristic	Pressure resistance
Rareflon (polytetrafluoroethylene)	10FF (standard parts)	Pure PTFE. Material that has superior heat, cold, and chemical resistance.	low ↑ ↓ high
	19YF	Standard material that has excellent extrusion and wear resistance even under high-pressure conditions.	
	49YF	Specialized material with further improved extrusion resistance compared to 19YF.	
Polyamide resin	80NP	Material for high-pressure use that has excellent extrusion and wear resistance, and it can be used for large-sized products made through machining.	
	12NM	Material for injection molding that has performance equivalent to 80NP, and it is less susceptible to dimensional changes caused by the absorption of moisture.	

* Polyamide resins may undergo dimensional changes due to the absorption of humidity. Please consult with NOK if you require moisture-proof packaging.

8. O-Ring Usage Methods (Types of Grooves) and Precautions

O-ring usage methods (groove types) and some precautions to observe are shown below.

As shown in Fig. 1-1 on page 14, it is necessary to take assembly workability into consideration when determining O-ring compression ratios. Such considerations are necessary to prevent the O-ring from being damaged due to scraping, gouging, or pinching during assembly and to avoid reduced workability during assembly due to increased rubber reaction force. From these reasons above, NOK recommends to set values of compression ratios, lower than their functional limit values. The reason why NOK recommends the compression ratios for cylindrical surface applications lower than flat face static applications is such assembly related considerations.

For more details on groove dimensions, please also refer to pages 22 to 59.

8 (1) For Cylindrical Surface Sealing

This method is used to form a seal using the inside and outside diameter surfaces of the O-ring as shown in Fig. 2-1. More careful consideration must be given toward assembly when compared to flat face static applications. For dynamic sealing, although it is vital to consider sealing performance, if it is set to a low compression value, this results in decreased sliding resistance.

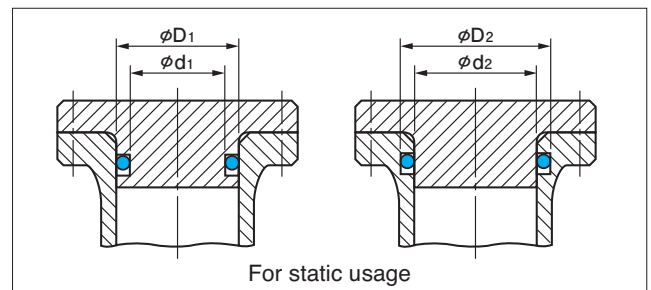
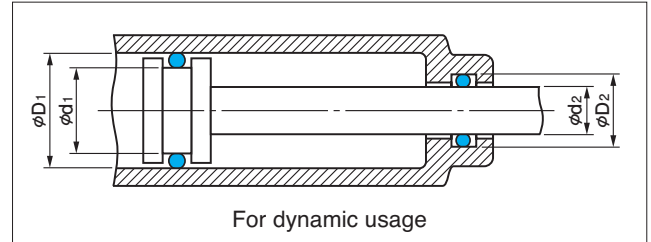

Fig. 2-1 Introduction on Cylindrical Surface Sealing Methods

(2) For Flat Face Static Sealing

• This method is used to form a seal using the top and bottom faces of the O-ring as shown in the figure to the right. As shown in Fig. 2-2, flat face static sealing can be categorized into 2 types: a) applications where internal pressure is applied and b) applications where external pressure is applied. NOK recommends in-groove O-ring positioning as following..

- For internal pressure application (a): O-ring outside diameter should be aligned with groove dimension D.
- For external pressure application (b): O-ring inside diameter should be aligned with groove dimension d.

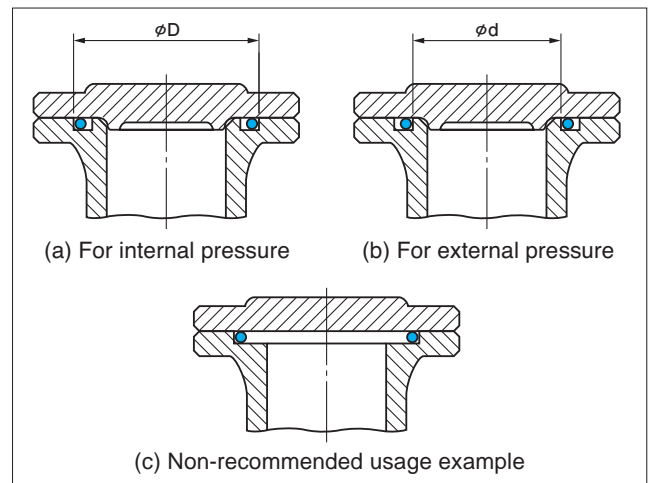

Fig. 2-2 Introduction on Flat Face Static Sealing Methods

Since the typical installation process will not be affected, a compression ratio larger than that applied for cylindrical surface applications is recommended when taking into consideration such factors as bolt elongation and flange deformation due to the pressure of applications.

Usage is not recommended in case where walls have not been added as shown in (c), since there is a risk that pressure fluctuations could result in wear or falling out of the O-ring.

- In case where the inside diameter is relatively large ($\phi 150$ or more) and thickness is relatively small ($\phi 3$ or less), since there is a risk that a portion of the O-ring could get torn off if it slips out and is squeezed as shown in Fig. 2-3, we recommend the usage of a product that is as thick as possible to prevent such pinching during assembly.
- Regarding O-rings with small inside diameters, since they may slip out during assembly making them difficult to assemble, please make sure to pay careful attention to such factors when selecting these items.
- Although there is a risk that failure may occur during installation for O-rings with relatively small dimensions (approx. $\phi 30$ or less), it is possible to alleviate such assembly related issues by selecting a product with a slightly larger D dimension (approx. 0.2 to 0.3 mm larger) for internal pressure applications or by selecting a product with a slightly smaller d dimension (approx. 0.2 to 0.3 mm smaller) for external pressure applications.

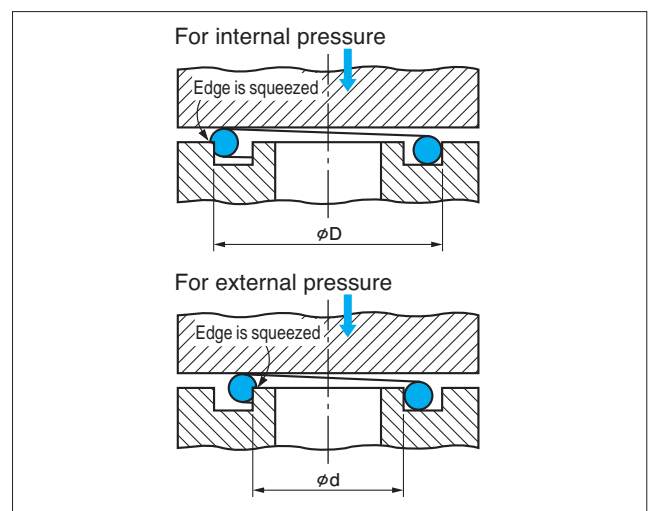

Fig. 2-3

(3) Types of Grooves

a) NOK's recommended groove structure is shown in Fig. 2-4. Additionally, other examples of groove structures are also indicated in Fig. 2-5 and Fig. 2-6. Since compression ratio and filling ratio for these additional groove shapes fall outside of NOK standards, they are only shown here for reference purposes.

For all of these structures, it is necessary to be careful about burrs and sharp edges to prevent the seal from being damaged.

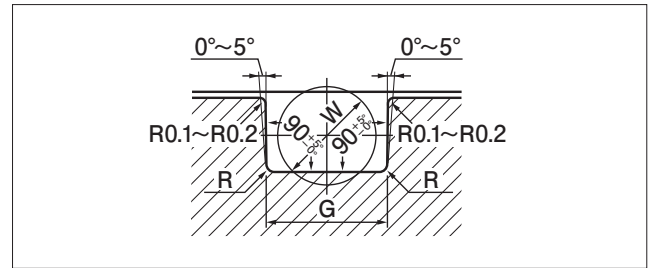

Fig. 2-4

[Reference]

b) Triangular groove applications

Although triangular grooves are occasionally used for the purposes of hardware simplicity, since triangular grooves cause compression of the O-ring from three directions as shown in Fig. 2-5, this will result in relatively high compression set for the O-ring.

When using this structure, for dimensions D and d shown in Fig. 2-5, please comply with the groove dimensions D and d given in the dimension table.

Additionally, dimension G should be set to 1.3 to 1.4 times W (W: O-ring thickness).

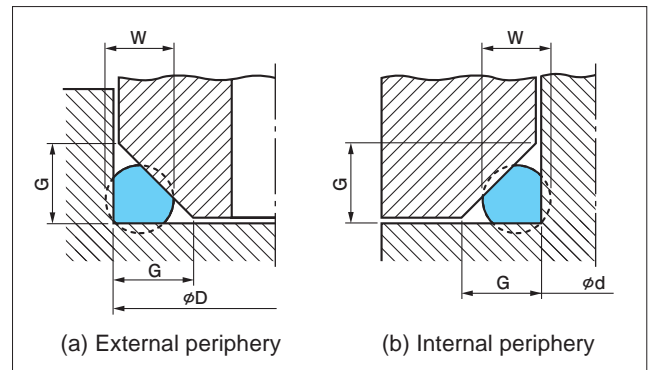
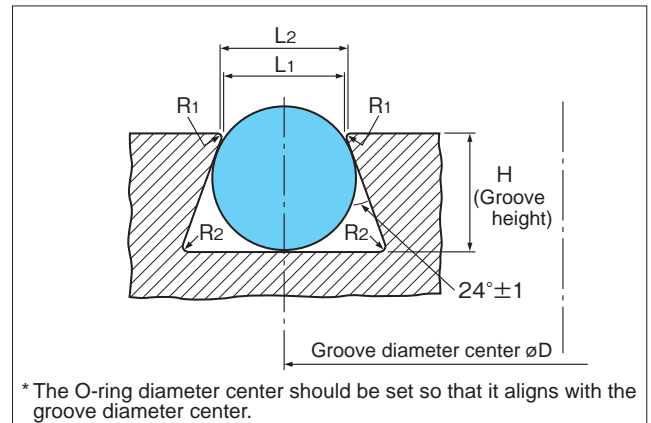

Fig. 2-5

c) Dovetail grooves applications

Although such structures are occasionally selected with the aim of preventing the O-ring from slipping out, they have a disadvantage of having a higher filling ratio.

It is necessary to be careful to prevent the occurrence of such issues as scratching or compression cracking of the seal during assembly. Please consult with NOK for information on more detailed dimensions.



* The O-ring diameter center should be set so that it aligns with the groove diameter center.

Fig. 2-6

① Determining General Use Dovetail Groove Dimensions [For Reference]

(Unit: mm)

Standard	O-rings		$L_1 \pm 0.05$		$H_{-0.05}^0$	R_1	$R_2 \text{ MAX}$
	Nominal number	Thickness (d ₂)	Before chamfering	After chamfering			
JIS B 2401-1	P3 - P10	1.9 ±0.08	1.55	1.70	1.4	0.15	0.40
	P10A - P22	2.4 ±0.09	2.00	2.20	1.8	0.20	0.40
	P22A - P50	3.5 ±0.10	2.95	3.15	2.8	0.20	0.80
	P48A - P150	5.7 ±0.13	4.75	5.20	4.7	0.40	0.80
	P150A - P400	8.4 ±0.15	7.10	7.65	7.0	0.50	1.60
	G25 - G145	3.1 ±0.10	2.60	2.80	2.4	0.20	0.80
	G150 - G300	5.7 ±0.13	4.75	5.20	4.7	0.40	0.80
AS568	004 - 050	1.78 ±0.07	1.45	1.60	1.30	0.15	0.40
	102 - 178	2.62 ±0.07	2.15	2.45	2.00	0.25	0.40
	201 - 284	3.53 ±0.10	2.95	3.20	2.80	0.25	0.80
	309 - 395	5.33 ±0.12	4.45	4.85	4.35	0.40	0.80
	425 - 475	6.98 ±0.15	5.95	6.35	5.75	0.40	1.60

② Determining Vacuum Use Dovetail Groove Dimensions [For Reference]

(Unit: mm)

Standard	O-rings		$L_1 \pm 0.05$		$H_{-0.05}^0$	R_1	$R_2 \text{ MAX}$
	Nominal number	Thickness (d ₂)	Before chamfering	After chamfering			
JIS B 2401-1	P22A - P50	3.5 ±0.10	3.05	3.25	2.5	0.20	0.80
	P48A - P150	5.7 ±0.13	4.95	5.40	4.2	0.40	0.80
	P150A - P400	8.4 ±0.15	7.35	7.90	6.3	0.50	1.60
	P150A - P400	4 ±0.10	3.45	3.75	2.9	0.30	0.80
	V15 - V175	6 ±0.13	5.25	5.70	4.4	0.40	0.80
	V480 - V1055	10 ±0.30	8.70	9.25	7.6	0.50	1.60
	AS568	201 - 284	3.53 ±0.10	3.05	3.35	2.5	0.25
AS568	309 - 395	5.33 ±0.12	4.60	5.05	3.9	0.40	0.80
AS568	425 - 475	6.98 ±0.15	6.12	6.55	5.2	0.40	1.60

9. Chamfering Design for Holes and Shafts

Since there is a risk that the edges of cylinders and piston rods may damage the O-ring during installation, please make sure to apply chamfering as given in Table 6-1. Furthermore, in order to prevent pinching of the O-ring caused by titling of the shaft during installation, we recommend that dimension L be set to $(G + b)$ or larger. For piston sealing, absolutely make sure to avoid adding pressure release holes to portions where the O-ring slides over. If the O-ring cannot be prevented from passing over such pressure release holes upon insertion, please add chamfering as shown in Figure 3-1.

Table 6-1 Rough Guide for Chamfering Dimensions (NOK Standards)

O-Ring Nominal number		a min.	b	
JIS	JASO		For a 15° angle	For a 30° angle
P 3 - P 10	1003 - 1035	0.9	3.4	1.6
P 10A - P 22	2010 - 2071	0.9	3.4	1.6
P 22A - P 50	3022 - 3150	1.1	4.1	1.9
P 48A - P 150		1.3	4.9	2.3
P 150A - P 500		1.5	5.6	2.6
G 25 - G145	3025S - 3145S	1.1	4.1	1.9
G150 - G500		1.3	4.9	2.3
NOK S standard	S 3 - S150	0.9	3.4	1.6
NOK SS standard	SS2 - SS12			

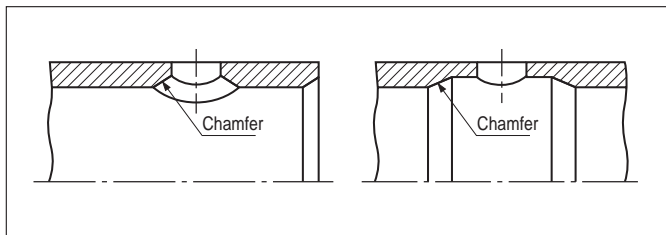
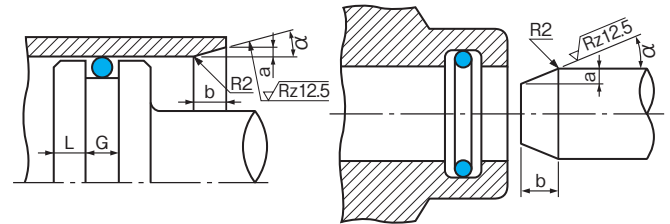

Fig. 3-1



10. Precautions for Special Applications

(1) For Vacuum Flange Sealing

When compared to general hydraulic sealing applications, it is necessary to pay particular attention to the following items when using O-rings for vacuum sealed equipment.

- Since the sealing medium in this case would be a gas, such applications will be more prone to leakage from contact surface gaps when compared to cases where the medium is a liquid. For this reason, it is necessary to pay particularly careful attention to surface roughness for contacting portions.
- When using rubber materials within a vacuum, since the permeation of gas molecules and dispersion of additives cannot be avoided, it will be necessary to select materials with the appropriate characteristics. Please refer to Table 3-1 on pages 8 through 9 when selecting such rubber materials.

(2) Pneumatic Dynamic Sealing

• O-rings used:

NOK recommends the usage of JIS B 2401-1 P Series O-rings (NOK material A305).

• Usage:

- 1) Please ensure that adequate lubrication is maintained through such as continuous oil lubrication.
- 2) If such lubrication cannot be performed, make sure that sufficient amounts of grease are applied, and make considerations to prevent grease shortages by adding a grease reservoir structure or by conducting periodic maintenance to account for this.

• Precautions:

- 1) Ensure that groove dimensions comply with those given in the JIS P Series dimension table.
For surface finishing, treatment please refer to Table 5-2 on page 14 and Table 6-1.
If you are using 2 O-rings for piston rod sealing applications, please refer to the dimensions shown in the figure to the right.
- 2) For the lubricant, please use of NOK KLÜBER "SEALUB-S1" or No. 2 consistency lithium soap-based grease. Generously apply the grease to fill the gaps between the O-rings or between the O-rings and the dust seal.
- 3) For low-friction dynamic usage, since it will be necessary to change the groove dimensions, please make sure to individually consult with NOK.

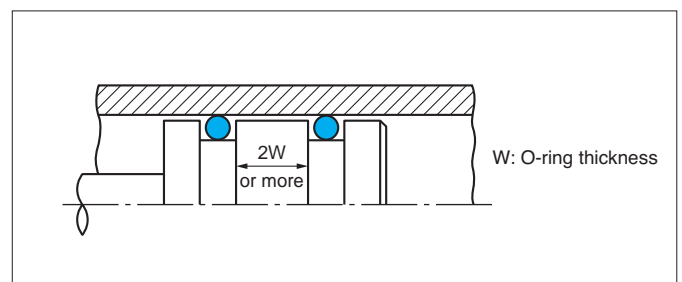

Fig. 4-1

- 4) NOK also offers pneumatic seals for pneumatic dynamic applications. Please consult with NOK if you are interested.

11. Precautions for O-Ring Installation

(1) Precautions During Assembly

- 1) For cases where chamfering cannot be added to the rod or where screw threads exist, please use a mounting jig as shown in Fig. 5-1 and make sure to exercise caution to prevent O-ring damage. By wrapping the screw portion with tape, etc., and by passing the O-ring over such portions, it will be possible to insert smoothly.

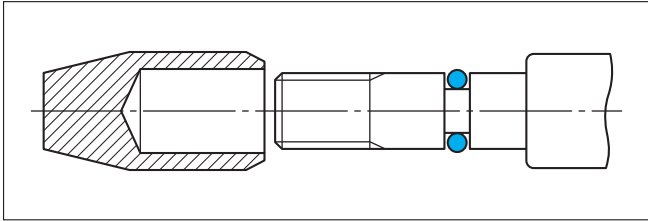

Fig. 5-1

- 2) Do not twist O-rings when installing them into grooves.

(2) Elongation Ratio of Installed O-Ring

If using a small diameter O-ring for cylindrical sealing applications, please comply with the standard that specifies that the maximum elongation ratio when installed should be less than 40% of rubber material elongation (EB).

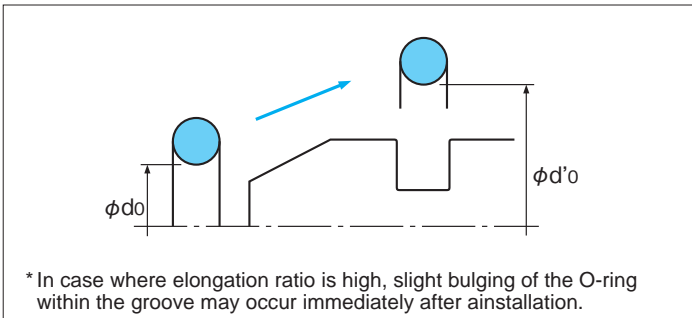

Fig. 5-3

- 3) Apply the sealing medium to the mating surface and O-rings during installation.
- 4) Do not reuse O-rings.
- 5) Do not clean the equipment using cleaning oil or gasoline while O-rings are still installed in grooves. This may cause the rubber material to swell.
- 6) Even in case where JIS standard O-rings and groove dimensions are used, as bulging on the inside diameter of the groove as shown in Fig. 5-2 may result depending on the different combinations of dimensional tolerances used, please make sure that O-rings are assembled in a manner where pinching does not occur.

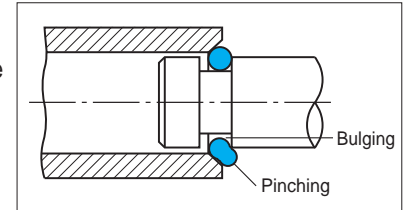

Fig. 5-2

(Example)

- ① Rubber material: A305
- ② Standard elongation (actual value): 340%
- ③ $\phi d_0 = 20$

- (1) As a standard, max. elongation ratio should be:
 $340\% \times 0.4 \div 140\%$ or less

- (2) Calculations for $\phi d'_0$:

$$\text{Elongation ratio} = \frac{(d'_0 - d_0)}{d_0} = \frac{d'_0}{d_0} - 1$$

$$\frac{d'_0}{d_0} = \text{Elongation ratio} + 1$$

$$\frac{d'_0}{d_0} = 1.4 + 1 = 2.4$$

$$d'_0 = d_0 \times 2.4 = 48$$

Based on this, it can be determined that $\phi d'_0$ can be elongated up to $\phi 48$.

12. Precautions for Storage, and Shelf Life

Please make sure to observe the following O-ring storage precautions.

- 1) Do not open the packaging unless needed. This can result in the adhesion of foreign substances or debris, or may result in damage.
- 2) When storing products that have already been opened, be careful to prevent adhesion or foreign substances or debris, and to prevent damage from occurring, and return the product to its packaging and restore it to its original condition as closely as possible.
- 3) Store products in a low-humidity location where they are not exposed to direct sunlight. Ultraviolet rays and humidity may hasten degradation of the rubber materials and may cause dimensional changes to occur.
- 4) Do not store products in locations that are close to high-temperature heat sources (boilers, stoves, etc.). Heat may hasten degradation of the rubber materials.
- 5) Avoid hanging O-rings from nails, wires, or ropes as this may result in deformation.
- 6) For nitrile rubber (NBR) or styrene-butadiene rubber (SBR) products, storage of such products in a condition where they are exposed to air may result in ozone cracking (refer to page 73).

Do not store products under the following conditions as this may cause such issues to more readily occur.

- Storage near electrical motors that are prone to emitting ozone gases (photocopiers, etc.).
- Keeping products stored in an elongated condition (this includes keeping O-rings stored while they are installed in grooves).

[Reference]

Although there are cases where discoloration or white powder may be observed (refer to blooming on page 71) on the stored product, such conditions will not affect O-ring functionality.

[Shelf life]

The shelf life for O-rings is shown in the table to the right. Please refer to this as a rough estimation on shelf life for products stored in their standard packaging in indoor environments while avoiding exposure to direct sunlight, high temperature, and high humidity.

Product	Material	Shelf life
Individual rubber product	Nitrile rubber (NBR)	10 years
	Silicone rubber (VMQ)	20 years
	Fluororubber (FKM)	20 years
	Acrylic rubber (ACM)	20 years
	Ethylene propylene rubber (EPDM)	20 years
	Hydrogenated nitrile rubber (HNBR)	10 years
	Styrene-butadiene rubber (SBR)	10 years
	Polyurethane rubber (AU)	10 years

13. JIS Dimension Identification Codes

JIS dimension identification codes consist of the following: “product type + material specification + dimensional specification + appearance grade.” (This dimension identification code is indicated on the packaging label.) Please make sure to specify the NOK part number and JIS dimension identification code when ordering JIS O-rings.

[Example]

OR NBR-70-1 P3-N

Product type is represented. Type of O-Ring is mentioned above.

Indicates the material specification. The material for the product shown above is: NBR-70-1 (A305)

Indicates the dimensional specification. The dimensions for the product shown above is: Size 3 of Series P

Indicates the appearance quality specification grade. Please refer to JIS B 2401-3 for more details.

* The NOK part number that corresponds to the JIS dimension identification code is “CO 0000A.”

14. Le-μ's: Low Friction(μ) Seals

Le-μ's
Low emission μ seal

High-performance seal brand
which contributes to the sustainable society by low friction technology.

Oil Seal	Seal Ring	O-Ring with SP Coating	Red Seal for Rotation and Oscillation	Oval-Ring with CNT
Reduce friction loss for rotary shaft seals like a motor while maintaining the sealing performance.	Reduce friction loss for rotary seal of the hydraulic circuit while maintaining the oil pressure.	Reduce insertion force of O-ring during assembly. Also, measures for temporary stop of a production process like parts feeder.	Reduce friction loss for rotary or oscillating rod seals under the high pressure while maintaining the sealing performance.	Maintaining sealing performance with less friction under high pressure hydro reciprocation.
DESIGN Tech. -45% <small>Decreased by lowering a pressure loss coefficient</small>	SURFACE Tech. -80% <small>20 μm/1mm to the sliding surface are coated</small>	SURFACE Tech. -70% <small>Low friction and low adhesion surface are formed by using fine film</small>	DESIGN Tech. -40% <small>Reduced seating force and reduced friction performance in the groove</small>	DESIGN Tech. -20% <small>Improving fitting performance, etc. and low friction needs</small>
SURFACE Tech. -30% <small>Optical treatment to smooth surface for reducing friction under high pressure condition</small>	DESIGN Tech. -70% <small>20 μm/1mm, coating, limited to complete from a shaft to an outer</small>	MATERIAL Tech. -30% <small>A special resin is coated to the contact surface which maintains pressure resistance and sliding performance</small>	MATERIAL Tech. +40% <small>Improving ultra-microscopic surface pressure treatment by adding Grit</small>	
MATERIAL Tech. -20% <small>Control of flow by optimized design of contact surface</small>				
GREASE Tech. -30% <small>Apply grease with low viscosity which is compatible with seal rubber</small>				

*Reduction of friction and improvement of pressure resistance ratios are compared to the conventional technology.

15. Dimension Tables for NOK Standard O-rings

O-RINGS

DIMENSION TABLE

	Page	15
JIS P Series	22	
JIS G Series	30	
NOK S Series	34	
NOK SS Series	36	
JIS V Series	37	
AS568 (old ARP568) Series	38	
Old JASO Thickness \varnothing 1.9 Series	46	
Old JASO Thickness \varnothing 2.4 Series	48	
Old JASO Thickness \varnothing 3.1 Series	50	
Old JASO Thickness \varnothing 3.5 Series	52	
ISO Equivalent General Industrial Series	54	
NOK WEX Series (O-Ring series for water applications)	57	
NOK Iron Rubber P, G Series	58	
JIS Equivalent Backup Rings	60	
 NOK SP Coating O-Ring Series	64	



High-performance brand that contributes to the environment through low-friction technologies

JIS B 2401-1 P Series (Static/Dynamic Applications)

■ When ordering, please make sure to specify both the ① JIS dimension identification code and ② NOK part number.
 Ex.1) If you wish to purchase a part with an inside diameter of 4.8 and thickness of 1.9 made of material NBR-70-1:
 • JIS identification code: OR NBR-70-1 P5-N
 • NOK part number: CO 00002 A
 Ex.2) If you wish to purchase a part with an inside diameter of 4.8 and thickness of 1.9 made of material FKM-70:
 • JIS identification code: OR FKM-70 P5-N
 • NOK part number: CO 00002 S7

Material	JIS	NBR-70-1	NBR-90	NBR-70-2	FKM-70	FKM-90	—
	Old JIS*	Class 1A	Class 1B	Class 2	Class 4D	—	Class 4C
	NOK code	A305	A105	A122	F201	F940	S503

*Old JIS: JIS B 2401-2005

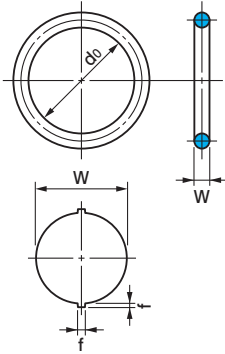

O-Ring Dimensions

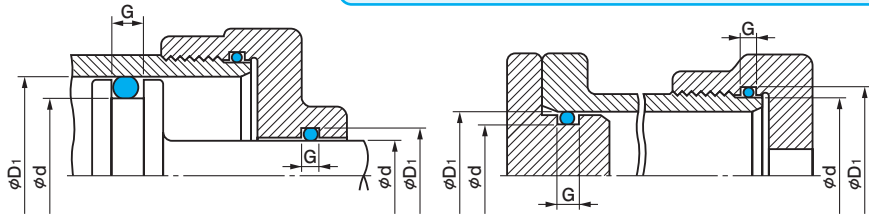

(Extrusion clearance: Refer to Fig. 1-3 on page 15.)

For Dynamic Applications

For Cylindrical Surface Static Applications

P Series

Type Dimension code	NOK part number						JIS dimension identification code		O-ring dimensions				
	Material code						Take the material code to the left and substitute it for the "□" (except for 4C).	(Reference) Old JIS nominal number	Thickness W	Inside diameter do	Tolerance of inside diameter 'do'		
	NBR-70-1 Class 1A A305	NBR-90 Class 1B A105	NBR-70-2 Class 2 A122	FKM-70 Class 4D F201	FKM-90 F940	4C** Class 4C S503					A305 (NBR-70-1) A105 (NBR-90) A122 (NBR-70-2)	F201 (FKM-70) F940 (FKM-90)	Class 4C S503
CO 00000 CO 00001 CO 00002 CO 00003 CO 00004	A	B	C	S8 R3	W1 V2	L	OR □ P 3 -N OR □ P 4 -N	P 3 P 4	1.9±0.08	2.8 3.8	±0.14	±0.16	±0.21
S7 G3				T8 H2	OR □ P 5 -N OR □ P 6 -N		P 5 P 6	4.8 5.8					
T7				Z2	OR □ P 7 -N		P 7	6.8					
U2 Q5 U8				P3 H1 Q2	OR □ P 8 -N OR □ P 9 -N OR □ P10 -N		P 8 P 9 P 10	7.8 8.8 9.8					
X8 X0				Z2 X2	OR □ P10A -N OR □ P11 -N		P 10A P 11	9.8 10.8					
U2 V8				D0 G2	OR □ P11.2 -N OR □ P12 -N		P 11.2 P 12	11.0 11.8					
Q0				Z1	OR □ P12.5 -N		P 12.5	12.3					
CO 00008 CO 00009 CO 00010 CO 00011 CO 00012	A	B	C	X0 U2	Y1 G2	L	OR □ P14 -N OR □ P15 -N	P 14 P 15	2.4±0.09	13.8 14.8	±0.18	±0.21	±0.27
V8 T8				Y1 Z2	OR □ P16 -N OR □ P18 -N		P 16 P 18	15.8 17.8					
R6				W1	OR □ P20 -N		P 20	19.8					
S5 U3				V1 Q1	OR □ P21 -N OR □ P22 -N		P 21 P 22	20.8 21.8					
U3 G0				O1 U0	OR □ P22A -N OR □ P22.4 -N		P 22A P 22.4	21.7 22.1					
U2 Q0				Y2 O1	OR □ P24 -N OR □ P25 -N		P 24 P 25	23.7 24.7					
G0				D0	OR □ P25.5 -N		P 25.5	25.2					
CO 00025 CO 00026 CO 00027 CO 00028 CO 00029	A	B	C	N5 U2	G2 G1	L	OR □ P26 -N OR □ P28 -N	P 26 P 28	3.5±0.1	25.7 27.7	±0.25	±0.30	±0.37
U3 G0				X0 D0	OR □ P29 -N OR □ P29.5 -N		P 29 P 29.5	28.7 29.2					
S0				Y0	OR □ P30 -N		P 30	29.7					
U3 D0				G1 D0	OR □ P31 -N OR □ P31.5 -N		P 31 P 31.5	30.7 31.2					
U3 R0				O1 G2	OR □ P32 -N OR □ P34 -N		P 32 P 34	31.7 33.7					
R0				Y0	OR □ P35 -N		P 35	34.7					
U2 U3				D0 E0	OR □ P35.5 -N OR □ P36 -N		P 35.5 P 36	35.2 35.7					
CO 00035 CO 00036 CO 00037 CO 00038 CO 00039	A	B	C	Q0 U2	R1 D0	L	OR □ P38 -N OR □ P39 -N	P 38 P 39	3.5±0.1	37.7 38.7	±0.31	±0.37	±0.46
U2 W0				D0 H1	OR □ P39 -N OR □ P40 -N		P 39 P 40	39.7					
U3 E0				G1 D0	OR □ P31 -N OR □ P31.5 -N		P 31 P 31.5	30.7 31.2					
U2 P3				W0 Q1	OR □ P44 -N OR □ P45 -N		P 44 P 45	43.7 44.7					
U3 W0				Y0	OR □ P35 -N		P 35	34.7					
U2 H0				G1 D0	OR □ P31 -N OR □ P31.5 -N		P 31 P 31.5	30.7 31.2					
U2 P3				W0 Q1	OR □ P44 -N OR □ P45 -N		P 44 P 45	43.7 44.7					
CO 00040 CO 00041 CO 00042 CO 00043 CO 00044	A	B	C	U3 U2	E0 H0	L	OR □ P41 -N OR □ P42 -N	P 41 P 42	3.5±0.1	40.7 41.7	±0.34	±0.40	±0.51
U2 P3				W0 Q1	OR □ P44 -N OR □ P45 -N		P 44 P 45	43.7 44.7					
U3 W0				Y0	OR □ P35 -N		P 35	34.7					
U2 H0				G1 D0	OR □ P31 -N OR □ P31.5 -N		P 31 P 31.5	30.7 31.2					
U2 P3				W0 Q1	OR □ P44 -N OR □ P45 -N		P 44 P 45	43.7 44.7					
CO 00040 CO 00041 CO 00042 CO 00043 CO 00044	A	B	C	U3 U2	E0 H0	L	OR □ P41 -N OR □ P42 -N	P 41 P 42	3.5±0.1	40.7 41.7	±0.37	±0.44	±0.55
U2 P3				W0 Q1	OR □ P44 -N OR □ P45 -N		P 44 P 45	43.7 44.7					
U3 W0				Y0	OR □ P35 -N		P 35	34.7					
U2 H0				G1 D0	OR □ P31 -N OR □ P31.5 -N		P 31 P 31.5	30.7 31.2					
U2 P3				W0 Q1	OR □ P44 -N OR □ P45 -N		P 44 P 45	43.7 44.7					
CO 00040 CO 00041 CO 00042 CO 00043 CO 00044	A	B	C	U3 U2	E0 H0	L	OR □ P41 -N OR □ P42 -N	P 41 P 42	3.5±0.1	40.7 41.7	±0.38	±0.45	±0.57
U2 P3				W0 Q1	OR □ P44 -N OR □ P45 -N		P 44 P 45	43.7 44.7					
U3 W0				Y0	OR □ P35 -N		P 35	34.7					
U2 H0				G1 D0	OR □ P31 -N OR □ P31.5 -N		P 31 P 31.5	30.7 31.2					
U2 P3				W0 Q1	OR □ P44 -N OR □ P45 -N		P 44 P 45	43.7 44.7					
CO 00040 CO 00041 CO 00042 CO 00043 CO 00044	A	B	C	U3 U2	E0 H0	L	OR □ P41 -N OR □ P42 -N	P 41 P 42	3.5±0.1	40.7 41.7	±0.39	±0.46	±0.58
U2 P3				W0 Q1	OR □ P44 -N OR □ P45 -N		P 44 P 45	43.7 44.7					
U3 W0				Y0	OR □ P35 -N		P 35	34.7					
U2 H0				G1 D0	OR □ P31 -N OR □ P31.5 -N		P 31 P 31.5	30.7 31.2					
U2 P3				W0 Q1	OR □ P44 -N OR □ P45 -N		P 44 P 45	43.7 44.7					
CO 00040 CO 00041 CO 00042 CO 00043 CO 00044	A	B	C	U3 U2	E0 H0	L	OR □ P41 -N OR □ P42 -N	P 41 P 42	3.5±0.1	40.7 41.7	±0.41	±0.49	±0.61
U2 P3				W0 Q1	OR □ P44 -N OR □ P45 -N		P 44 P 45	43.7 44.7					
U3 W0				Y0	OR □ P35 -N		P 35	34.7					
U2 H0				G1 D0	OR □ P31 -N OR □ P31.5 -N		P 31 P 31.5	30.7 31.2					
U2 P3				W0 Q1	OR □ P44 -N OR □ P45 -N		P 44 P 45	43.7 44.7					
CO 00040 CO 00041 CO 00042 CO 00043 CO 00044	A	B	C	U3 U2	E0 H0	L	OR □ P41 -N OR □ P42 -N	P 41 P 42	3.5±0.1	40.7 41.7	±0.42	±0.50	±0.63
U2 P3				W0 Q1	OR □ P44 -N OR □ P45 -N		P 44 P 45	43.7 44.7					
U3 W0				Y0	OR □ P35 -N		P 35	34.7					
U2 H0				G1 D0	OR □ P31 -N OR □ P31.5 -N		P 31 P 31.5	30.7 31.2					
U2 P3				W0 Q1	OR □ P44 -N OR □ P45 -N		P 44 P 45	43.7 44.7					
CO 00040 CO 00041 CO 00042 CO 00043 CO 00044	A	B	C	U3 U2	E0 H0	L	OR □ P41 -N OR □ P42 -N	P 41 P 42	3.5±0.1	40.7 41.7	±0.44	±0.52	±0.66
U2 P3				W0 Q1	OR □ P44 -N OR □ P45 -N		P 44 P 45	43.7 44.7					
U3 W0				Y0	OR □ P35 -N		P 35	34.7					
U2 H0				G1 D0	OR □ P31 -N OR □ P31.5 -N		P 31 P 31.5	30.7 31.2					
U2 P3				W0 Q1	OR □ P44 -N OR □ P45 -N		P 44 P 45	43.7 44.7					
CO 00040 CO 00041 CO 00042 CO 00043 CO 00044	A	B	C	U3 U2	E0 H0	L	OR □ P41 -N OR □ P42 -N	P 41 P 42	3.5±0.1	40.7 41.7	±0.45	±0.55	±0.66
U2 P3				W0 Q1	OR □ P44 -N OR □ P45 -N		P 44 P 45	43.7 44.7					
U3 W0				Y0	OR □ P35 -N		P 35	34.7					
U2 H0				G1 D0	OR □ P31 -N OR □ P31.5 -N		P 31 P 31.5	30.7 31.2					
U2 P3				W0 Q1	OR □ P44 -N OR □ P45 -N		P 44 P 45	43.7 44.7					

**Dimension identification codes for 4C are given as follows: "4C□". Please take the Old JIS nominal number and substitute it for the "□".
 Ex. 3) For parts with an inside diameter of 2.8 and a thickness of 1.9: 4CP3

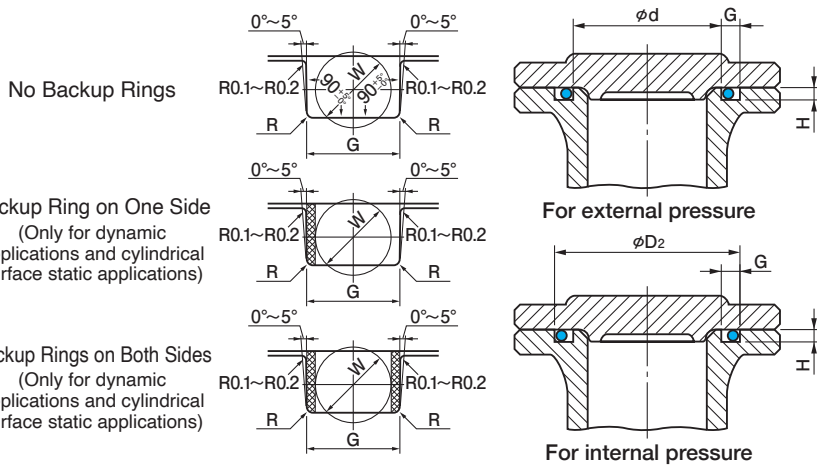

(Note) Chamfering is indicated in accordance with NOK recommended values.

Groove Shapes For Flat Face Static Applications

■ JIS dimension identification codes represent “product type + material specification + dimensional specification + appearance grade.”

■ We also offer parts with the same dimensions as the Old JASO standards in addition to the materials given for the following lineups. Please refer to pages 46 through 53 for more details.

- Class 3 (SBR materials)
- Class 4E (acrylic materials)
- Class 5 (EPDM materials)
- Material H (H-NBR materials)

(Unit: mm)

Groove dimensions (based on JIS standard values)																			
Composite burr dimension f	Dimension d		Dimensions D ₁ , D ₂			Dimension G (tolerance $^{+0.25}_0$)			Dimension H	Dimension R	Max. center misalignment (TIR) of D and d for dynamic or cylindrical surface static applications								
	d	Tolerance	D ₁	D ₂	Tolerance	No backup rings	Backup ring on one side	Backup rings on both sides	H±0.05	Max. value									
0.10 or less	3	0 -0.05	6	6.2	+0.05 0	2.5	3.9	5.4	1.4	0.4	0.05								
	4		7	7.2															
	5		8	8.2															
	6		9	9.2															
	7		10	10.2															
	8		11	11.2															
	9		12	12.2															
	10		13	13.2															
	0.12 or less		10	0 -0.06								14	+0.06 0	3.2	4.4	6.0	1.8	0.4	0.05
			11									15							
11.2		15.2																	
12		16																	
12.5		16.5																	
14		18																	
15		19																	
16		20																	
18		22																	
20		24																	
0.14 or less	21	0 -0.08	25	+0.08 0	4.7	6.0	7.8	2.7	0.8	0.08									
	22		26																
	22.4		28																
	24		28.4																
	25		30																
	25.5		31																
			31.5																
	26		32																
	28		34																
	29		35																
	29.5		35.5																
	30		36																
	31		37																
	31.5		37.5																
	32		38																
	34		40																
	35		41																
	35.5		41.5																
36	42																		
38	44																		
39	45																		
40	46																		
41	47																		
42	48																		
44	50																		
45	51																		
46	52																		
48	54																		

JIS B 2401-1 P Series (Static/Dynamic Applications)

■ When ordering, please make sure to specify both the ① JIS dimension identification code and ② NOK part number.
 Ex.1) If you wish to purchase a part with an inside diameter of 48.7 and thickness of 3.5 made of material NBR-70-1:
 • JIS identification code: OR NBR-70-1 P49-N
 • NOK part number: CO 00047 A
 Ex.2) If you wish to purchase a part with an inside diameter of 48.7 and thickness of 3.5 made of material FKM-70:
 • JIS identification code: OR FKM-70 P49-N
 • NOK part number: CO 00047 O0

Material	JIS	NBR-70-1	NBR-90	NBR-70-2	FKM-70	FKM-90	—
	Old JIS *	Class 1A	Class 1B	Class 2	Class 4D	—	Class 4C
	NOK code	A305	A105	A122	F201	F940	S503

*Old JIS: JIS B 2401-2005

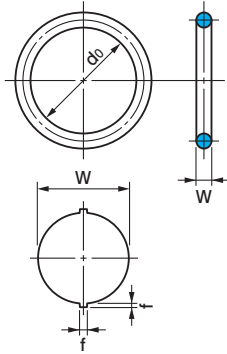

O-Ring Dimensions

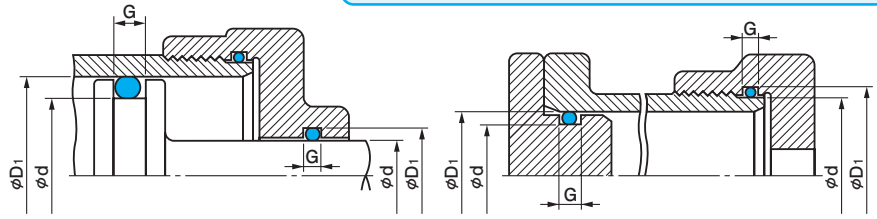

(Extrusion clearance: Refer to Fig.1-3 on page 15.)

For Dynamic Applications

For Cylindrical Surface Static Applications

P Series

Type Dimension code	NOK part number						JIS dimension identification code		O-ring dimensions				
	Material code						Take the material code to the left and substitute it for the "□" (except for 4C).	(Reference) Old JIS nominal number	Thickness W	Inside diameter do	Tolerance of inside diameter 'do'		
	NBR-70-1	NBR-90	NBR-70-2	FKM-70	FKM-90	4C**					A305 (NBR-70-1)	F201 (FKM-70)	Class 4C
	Class 1A A305	Class 1B A105	Class 2 A122	Class 4D F201	F940	Class 4C S503					(NBR-90) A122 (NBR-70-2)	F940 (FKM-90)	S503
CO 00047 CO 00049	A	B	C	O0 Q5	W0 G1	L	OR □ P 49 -N OR □ P 50 -N	P 49 P 50	3.5±0.1	48.7 49.7	±0.45	±0.54	±0.67
CO 00045 CO 00048 CO 00050 CO 00051 CO 00052				G0 U3 U3 G0 U3	D0 D0 D0 E0 Y0		OR □ P 48A-N OR □ P 50A-N OR □ P 52 -N OR □ P 53 -N OR □ P 55 -N	P 48A P 50A P 52 P 53 P 55		47.6 49.6 51.6 52.6 54.6	±0.44 ±0.45 ±0.47 ±0.48 ±0.49	±0.52 ±0.54 ±0.56 ±0.57 ±0.58	±0.66 ±0.67 ±0.70 ±0.72 ±0.73
CO 00053 CO 00054 CO 00055 CO 00056 CO 00057				U3 G0 U3 U3 H0	D0 D0 D0 X0 D0		OR □ P 56 -N OR □ P 58 -N OR □ P 60 -N OR □ P 62 -N OR □ P 63 -N	P 56 P 58 P 60 P 62 P 63		55.6 57.6 59.6 61.6 62.6	±0.50 ±0.52 ±0.53 ±0.55 ±0.56	±0.60 ±0.62 ±0.63 ±0.66 ±0.67	±0.75 ±0.78 ±0.79 ±0.82 ±0.84
CO 00058 CO 00059 CO 00060 CO 00061 CO 00062				H0 U3 O0 U3 U3	Z1 D0 Y0 D0 R1		OR □ P 65 -N OR □ P 67 -N OR □ P 70 -N OR □ P 71 -N OR □ P 75 -N	P 65 P 67 P 70 P 71 P 75		64.6 66.6 69.6 70.6 74.6	±0.57 ±0.59 ±0.61 ±0.62 ±0.65	±0.68 ±0.70 ±0.73 ±0.74 ±0.78	±0.85 ±0.88 ±0.91 ±0.93 ±0.97
CO 00063 CO 00064 CO 00065 CO 00066 CO 00067	A	B	C	Q0 G0 U3 U3 T0	X0 Z0 X1 X0 P1	L	OR □ P 80 -N OR □ P 85 -N OR □ P 90 -N OR □ P 95 -N OR □ P100 -N	P 80 P 85 P 90 P 95 P100	5.7±0.13	79.6 84.6 89.6 94.6 99.6	±0.69 ±0.73 ±0.77 ±0.81 ±0.84	±0.82 ±0.87 ±0.92 ±0.97 ±1.00	±1.03 ±1.09 ±1.15 ±1.21 ±1.26
CO 00068 CO 00069 CO 00070 CO 00071 CO 00072				U3 U3 U3 G0 U3	D0 Z0 Z0 Q0 D0		OR □ P102 -N OR □ P105 -N OR □ P110 -N OR □ P112 -N OR □ P115 -N	P102 P105 P110 P112 P115		101.6 104.6 109.6 111.6 114.6	±0.85 ±0.87 ±0.91 ±0.92 ±0.94	±1.02 ±1.04 ±1.09 ±1.10 ±1.12	±1.27 ±1.30 ±1.36 ±1.38 ±1.41
CO 00073 CO 00074 CO 00075 CO 00076 CO 00077				U3 U3 T0 U3 U3	V1 Y0 Z0 D0 Y0		OR □ P120 -N OR □ P125 -N OR □ P130 -N OR □ P132 -N OR □ P135 -N	P120 P125 P130 P132 P135		119.6 124.6 129.6 131.6 134.6	±0.98 ±1.01 ±1.05 ±1.06 ±1.09	±1.17 ±1.21 ±1.26 ±1.27 ±1.30	±1.47 ±1.51 ±1.57 ±1.59 ±1.63
CO 00078 CO 00079 CO 00081				U3 U3 S0	H3 Y0 D0		OR □ P140 -N OR □ P145 -N OR □ P150 -N	P140 P145 P150		139.6 144.6 149.6	±1.12 ±1.16 ±1.19	±1.34 ±1.39 ±1.42	±1.68 ±1.74 ±1.78
CO 00080 CO 00082				U3 U3			OR □ P150A-N OR □ P155 -N	P150A P155		149.5 154.5	±1.19 ±1.23	±1.42 ±1.47	±1.78 ±1.84
CO 00083 CO 00084 CO 00085 CO 00086 CO 00087	A	B	C	G0 G0 U3 G0 P0		L	OR □ P160 -N OR □ P165 -N OR □ P170 -N OR □ P175 -N OR □ P180 -N	P160 P165 P170 P175 P180	8.4±0.15	159.5 164.5 169.5 174.5 179.5	±1.26 ±1.30 ±1.33 ±1.37 ±1.40	±1.51 ±1.56 ±1.59 ±1.64 ±1.68	±1.89 ±1.95 ±1.99 ±2.05 ±2.10
CO 00088 CO 00089 CO 00090 CO 00091				U3 U3 G0 G0			OR □ P185 -N OR □ P190 -N OR □ P195 -N OR □ P200 -N	P185 P190 P195 P200		184.5 189.5 194.5 199.5	±1.44 ±1.48 ±1.51 ±1.55	±1.72 ±1.77 ±1.81 ±1.86	±2.16 ±2.22 ±2.26 ±2.32

**Dimension identification codes for 4C are given as follows: "4C□". Please take the Old JIS nominal number and substitute it for the "□".

Ex. 3) For parts with an inside diameter of 48.7 and a thickness of 3.5: 4CP49

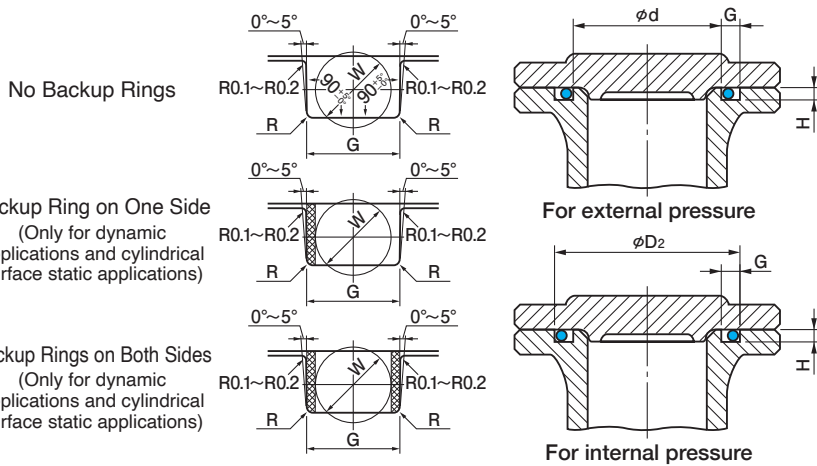

(Note) Chamfering is indicated in accordance with NOK recommended values.

Groove Shapes For Flat Face Static Applications

■ JIS dimension identification codes represent “product type + material specification + dimensional specification + appearance grade.”

■ We also offer parts with the same dimensions as the Old JASO standards in addition to the materials given for the following lineups. Please refer to pages 46 through 53 for more details.

- Class 3 (SBR materials)
- Class 4E (acrylic materials)
- Class 5 (EPDM materials)
- Material H (H-NBR materials)

(Unit: mm)

Groove dimensions (based on JIS standard values)											
Composite burr dimension f	Dimension d		Dimensions D ₁ , D ₂		Dimension G (tolerance $^{+0.25}_0$)			Dimension H	Dimension R	Max. center misalignment (TIR) of D and d for dynamic or cylindrical surface static applications	
	d	Tolerance	D ₁ , D ₂	Tolerance	No backup rings	Backup ring on one side	Backup rings on both sides	H±0.05	Max. value		
0.140 or less	49	0	55	+0.08	4.7	6.0	7.8	2.7	0.8	0.08	
	50		56								0
0.16 or less	48	-0.10	58	+0.10	7.5	9.0	11.5	4.6	0.8	0.10	
	50		60								
	52		62								
	53		63								
	55		65								
	56		66								
	58		68								
	60		70								
	62		72								
	63		73								
	65		75								
	67		77								
	70		80								
	71		81								
	75		85								
	80		90								
	85		95								
	90		100								
	95		105								
	100		110								
	102		112								
	105		115								
	110		120								
	112		122								
115	125										
120	130										
125	135										
130	140										
132	142										
135	145										
140	150										
145	155										
150	160										
0.18 or less	150	-0.10	165	+0.10	11.0	13.0	17.0	6.9	1.2	0.12	
	155		170								
	160		175								
	165		180								
	170		185								
	175		190								
	180		195								
	185		200								
	190		205								
	195		210								
	200		215								

JIS B 2401-1 P Series (Static/Dynamic Applications)

■ When ordering, please make sure to specify both the ① JIS dimension identification code and ② NOK part number.
 Ex.1) If you wish to purchase a part with an inside diameter of 204.5 and thickness of 8.4 made of material NBR-70-1:
 • JIS identification code: OR NBR-70-1 P205-N
 • NOK part number: CO 00092 A
 Ex.2) If you wish to purchase a part with an inside diameter of 204.5 and thickness of 8.4 made of material FKM-70:
 • JIS identification code: OR FKM-70 P205-N
 • NOK part number: CO 00092 G0

Material	JIS	NBR-70-1	NBR-90	NBR-70-2	FKM-70	FKM-90	—
	Old JIS*	Class 1A	Class 1B	Class 2	Class 4D	—	Class 4C
	NOK code	A305	A105	A122	F201	F940	S503

*Old JIS: JIS B 2401-2005

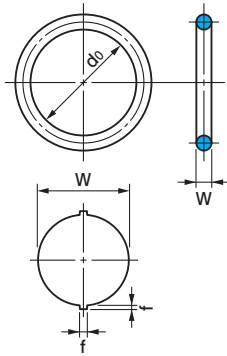

O-Ring Dimensions

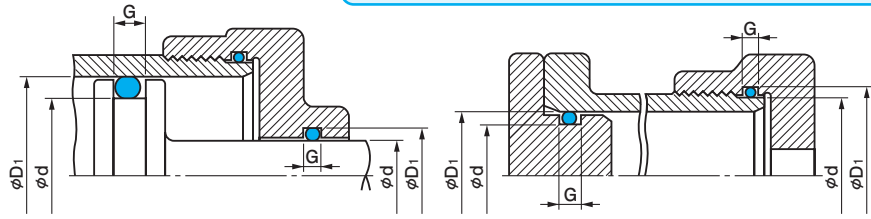

(Extrusion clearance: Refer to Fig.1-3 on page 15.)

For Dynamic Applications

For Cylindrical Surface Static Applications

P Series

Type Dimension code	NOK part number						JIS dimension identification code		O-ring dimensions				
	Material code						Take the material code to the left and substitute it for the "□" (except for 4C).	(Reference) Old JIS nominal number	Thickness W	Inside diameter do	Tolerance of inside diameter 'do'		
	NBR-70-1	NBR-90	NBR-70-2	FKM-70	FKM-90	4C**					A305 (NBR-70-1)	F201 (FKM-70)	Class 4C
	Class 1A A305	Class 1B A105	Class 2 A122	Class 4D F201	F940	Class 4C S503					A105 (NBR-90)	F940 (FKM-90)	S503
CO 00092				G0			OR □ P205-N	P205	8.4±0.15	204.5	±1.58	±1.89	±2.37
CO 00093				O0			OR □ P209-N	P209		208.5	±1.61	±1.93	±2.41
CO 00094				H0			OR □ P210-N	P210		209.5	±1.62	±1.94	±2.43
CO 00095				G0			OR □ P215-N	P215		214.5	±1.65	±1.98	±2.47
CO 00096				U3			OR □ P220-N	P220		219.5	±1.68	±2.01	±2.52
CO 00097				G0			OR □ P225-N	P225		224.5	±1.71	±2.05	±2.56
CO 00098				U3			OR □ P230-N	P230		229.5	±1.75	±2.10	±2.62
CO 00099				U3			OR □ P235-N	P235		234.5	±1.78	±2.13	±2.67
CO 00100				H0			OR □ P240-N	P240		239.5	±1.81	±2.17	±2.71
CO 00101				U3			OR □ P245-N	P245		244.5	±1.84	±2.20	±2.76
CO 00102		B	C	G0		L	OR □ P250-N	P250		249.5	±1.88	±2.25	±2.82
CO 00103				G0			OR □ P255-N	P255		254.5	±1.91	±2.29	±2.86
CO 00104				U3			OR □ P260-N	P260		259.5	±1.94	±2.32	±2.91
CO 00105				G0			OR □ P265-N	P265		264.5	±1.97	±2.36	±2.95
CO 00106				G0			OR □ P270-N	P270		269.5	±2.01	±2.41	±3.01
CO 00107				G0			OR □ P275-N	P275	274.5	±2.04	±2.44	±3.06	
CO 00108				G0			OR □ P280-N	P280	279.5	±2.07	±2.48	±3.10	
CO 00109				N0			OR □ P285-N	P285	284.5	±2.10	±2.52	±3.15	
CO 00110				N0			OR □ P290-N	P290	289.5	±2.14	±2.56	±3.21	
CO 00111				G0			OR □ P295-N	P295	294.5	±2.17	±2.60	±3.25	
CO 00112				N0			OR □ P300-N	P300	299.5	±2.20	±2.64	±3.30	
CO 02147*							OR □ P305-N*	P305*	304.5	±2.24	±2.69	—	
CO 08835*				G0			OR □ P310-N*	P310*	309.5	±2.27	±2.72	—	
CO 00113	A	B	C	O0		L	OR □ P315-N	P315	314.5	±2.30	±2.76	±3.45	
CO 00114				G0			OR □ P320-N	P320	319.5	±2.33	±2.79	±3.49	
CO 08836*				G0			OR □ P325-N*	P325*	324.5	±2.36	±2.83	—	
CO 07645*							OR □ P330-N*	P330*	329.5	±2.39	±2.87	—	
CO 00115		B	C	G0		L	OR □ P335-N	P335	334.5	±2.42	±2.90	±3.63	
CO 00116				N0			OR □ P340-N	P340	339.5	±2.45	±2.94	±3.67	
CO 08837*							OR □ P345-N*	P345*	344.5	±2.48	±2.98	—	
CO 06615*				G0			OR □ P350-N*	P350*	349.5	±2.51	±3.01	—	
CO 00117		B	C	G0		L	OR □ P355-N	P355	354.5	±2.54	±3.04	±3.81	
CO 00118							OR □ P360-N	P360	359.5	±2.57	±3.08	±3.85	
CO 06630*				G0			OR □ P365-N*	P365*	364.5	±2.60	±3.12	—	
CO 08838*							OR □ P370-N*	P370*	369.5	±2.63	±3.16	—	
CO 00119		B	C	G0		L	OR □ P375-N	P375	374.5	±2.67	±3.20	±4.00	
CO 02274*				G0			OR □ P380-N*	P380*	379.5	±2.70	±3.24	—	
CO 00120		B	C	G0		L	OR □ P385-N	P385	384.5	±2.73	±3.27	±4.09	
CO 06650*				G0			OR □ P390-N*	P390*	389.5	±2.77	±3.32	—	
CO 08839*							OR □ P395-N*	P395*	394.5	±2.79	±3.35	—	
CO 00121		B	C	G0		L	OR □ P400-N	P400	399.5	±2.82	±3.38	±4.23	
CO 02311*							OR □ P405-N*	P405*	404.5	—	—	—	
CO 06663*							OR □ P410-N*	P410*	409.5	—	—	—	
CO 02337*							OR □ P415-N*	P415*	414.5	—	—	—	
CO 08840*				G0			OR □ P420-N*	P420*	419.5	±3.00	±3.60	—	
CO 02359*							OR □ P425-N*	P425*	424.5	—	—	—	
CO 02371*							OR □ P430-N*	P430*	429.5	—	—	—	

*For these code numbers, only rubber materials A305 and F201 are available.

**Dimension identification codes for 4C are given as follows: "4C□". Please take the Old JIS nominal number and substitute it for the "□".
 Ex. 3) For parts with an inside diameter of 204.5 and a thickness of 8.4: 4CP205

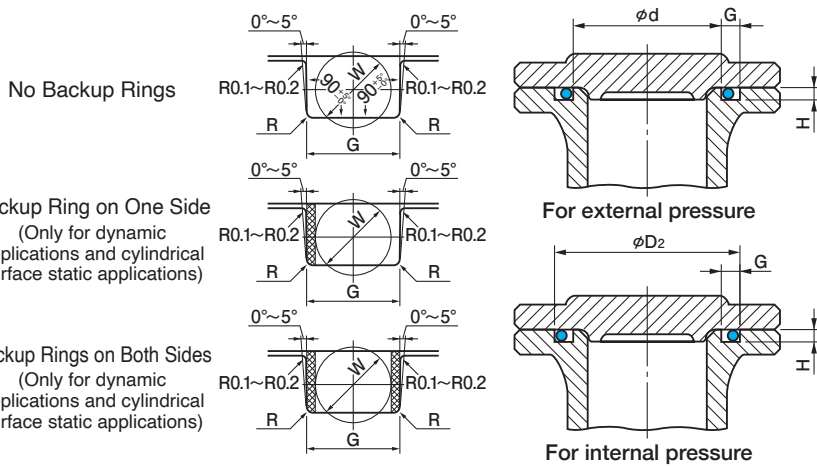

(Note) Chamfering is indicated in accordance with NOK recommended values.

Groove Shapes For Flat Face Static Applications

■ JIS dimension identification codes represent “product type + material specification + dimensional specification + appearance grade.”

■ We also offer parts with the same dimensions as the Old JASO standards in addition to the materials given for the following lineups. Please refer to pages 46 through 53 for more details.

- Class 3 (SBR materials)
- Class 4E (acrylic materials)
- Class 5 (EPDM materials)
- Material H (H-NBR materials)

(Unit: mm)

Groove dimensions (based on JIS standard values)											
Composite burr dimension f	Dimension d		Dimensions D ₁ , D ₂		Dimension G (tolerance $^{+0.25}_0$)			Dimension H	Dimension R	Max. center misalignment (TIR) of D and d for dynamic or cylindrical surface static applications	
	d	Tolerance	D ₁ , D ₂	Tolerance	No backup rings	Backup ring on one side	Backup rings on both sides	H±0.05	Max. value		
0.18 or less	205	-0.10	220	+ 0.10 0	11.0	13.0	17.0	6.9	1.2	0.12	
	209		224								
	210		225								
	215		230								
	220		235								
	225		240								
	230		245								
	235		250								
	240		255								
	245		260								
	250		265								
	255		270								
	260		275								
	265		280								
	270		285								
	275		290								
	280		295								
	285		300								
	290		305								
	295		310								
	300		315								
	305		320								
	310		325								
	315		330								
	320		335								
	325		340								
	330		345								
	335		350								
	340		355								
	345		360								
	350		365								
	355		370								
	360		375								
	365		380								
	370		385								
	375		390								
380	395										
385	400										
390	405										
395	410										
400	415										
405	420										
410	425										
415	430										
420	435										
425	440										
430	445										

JIS B 2401-1 P Series (Static/Dynamic Applications)

■ When ordering, please make sure to specify both the ① JIS dimension identification code and ② NOK part number.
 Ex.1) If you wish to purchase a part with an inside diameter of 434.5 and thickness of 8.4 made of material NBR-70-1:
 • JIS identification code: OR NBR-70-1 P435-N
 • NOK part number: CO 02383 A
 Ex.2) If you wish to purchase a part with an inside diameter of 434.5 and thickness of 8.4 made of material FKM-70:
 • JIS identification code: OR FKM-70 P435-N
 • NOK part number: CO 02383 G0

Material	JIS	NBR-70-1	NBR-90	NBR-70-2	FKM-70	FKM-90	—
	Old JIS*	Class 1A	Class 1B	Class 2	Class 4D	—	Class 4C
	NOK code	A305	A105	A122	F201	F940	S503

*Old JIS: JIS B 2401-2005

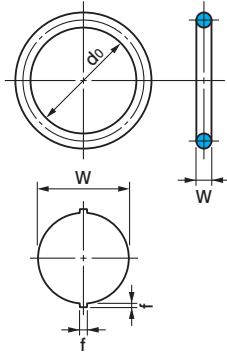

O-Ring Dimensions

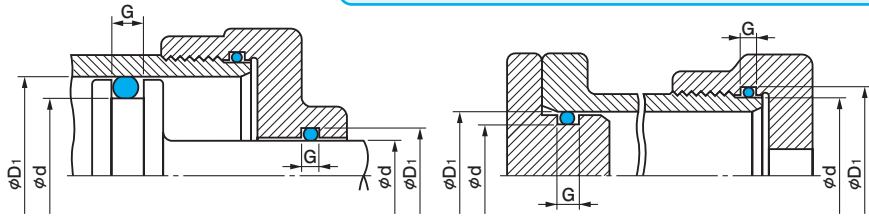

(Extrusion clearance: Refer to Fig.1-3 on page 15.)

For Dynamic Applications

For Cylindrical Surface Static Applications

P Series

Type Dimension code	NOK part number						JIS dimension identification code		O-ring dimensions				
	Material code						Take the material code to the left and substitute it for the "□" (except for 4C).	(Reference) Old JIS nominal number	Thickness W	Inside diameter do	Tolerance of inside diameter 'do'		
	NBR-70-1	NBR-90	NBR-70-2	FKM-70	FKM-90	4C**					A305 (NBR-70-1)	F201 (FKM-70)	Class 4C
Class 1A	Class 1B	Class 2	Class 4D	F940	Class 4C				A105 (NBR-90)	F940 (FKM-90)	S503		
CO 02383*				G0			OR □ P435-N*	P435*	8.4 ± 0.15	434.5 439.5 444.5 449.5	±3.00	±3.60	—
CO 08841*				G0			OR □ P440-N*	P440*					
CO 06681*				G0			OR □ P445-N*	P445*					
CO 08842*				G0			OR □ P450-N*	P450*					
CO 02433*	A	—	—	G0	—	—	OR □ P455-N*	P455*	8.4 ± 0.15	454.5 459.5 464.5 469.5 474.5	±3.30	±4.00	—
CO 08843*				G0			OR □ P460-N*	P460*					
CO 02453*				H0			OR □ P465-N*	P465*					
CO 08844*				G0			OR □ P470-N*	P470*					
CO 08845*				G0			OR □ P475-N*	P475*					
CO 06734*				G0			OR □ P480-N*	P480*	8.4 ± 0.15	479.5 484.5 489.5 494.5 499.5	±3.30	±4.00	—
CO 09165*				G0			OR □ P485-N*	P485*					
DO 09015*				G0			OR □ P490-N*	P490*					
DO 09016*				G0			OR □ P495-N*	P495*					
CO 09057*				G0			OR □ P500-N*	P500*					

*For these code numbers, only rubber materials A305 and F201 are available.

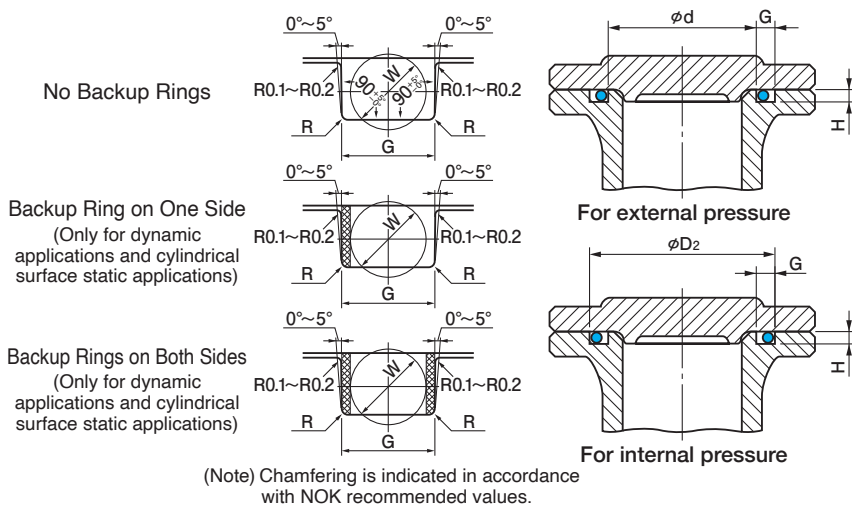

Groove Shapes For Flat Face Static Applications

■ JIS dimension identification codes represent “product type + material specification + dimensional specification + appearance grade.”

■ We also offer parts with the same dimensions as the Old JASO standards in addition to the materials given for the following lineups.

Please refer to pages 46 through 53 for more details.

- Class 3 (SBR materials)
- Class 4E (acrylic materials)
- Class 5 (EPDM materials)
- Material H (H-NBR materials)

(Unit: mm)

Groove dimensions (based on JIS standard values)											
Composite burr dimension f	Dimension d		Dimensions D ₁ , D ₂		Dimension G (tolerance $^{+0.25}_0$)			Dimension H	Dimension R	Max. center misalignment (TIR) of D and d for dynamic or cylindrical surface static applications	
	d	Tolerance	D ₁ , D ₂	Tolerance	No backup rings	Backup ring on one side	Backup rings on both sides	H±0.05	Max. value		
0.18 or less	435	0 -0.10	450	+ 0.10 0	11.0	13.0	17.0	6.9	1.2	0.12	
	440		455								
	445		460								
	450		465								
0.18 or less	455		470								
	460		475								
	465		480								
	470		485								
	475		490								
	480		495								
	485		500								
	490		505								
	495	510									
	500	515									

JIS B 2401-1 G Series (Static Applications)

■ When ordering, please make sure to specify both the ① JIS dimension identification code and ② NOK part number.
 Ex.1) If you wish to purchase a part with an inside diameter of 24.4 and thickness of 3.1 made of material NBR-70-1:
 • JIS identification code: OR NBR-70-1 G25-N
 • NOK part number: CO 00200 A
 Ex.2) If you wish to purchase a part with an inside diameter of 24.4 and thickness of 3.1 made of material FKM-70:
 • JIS identification code: OR FKM-70 G25-N
 • NOK part number: CO 00200 R6

Material	JIS	NBR-70-1	NBR-90	NBR-70-2	FKM-70	FKM-90	—
	Old JIS*	Class 1A	Class 1B	Class 2	Class 4D	—	Class 4C
	NOK code	A305	A105	A122	F201	F940	S503

*Old JIS: JIS B 2401-2005

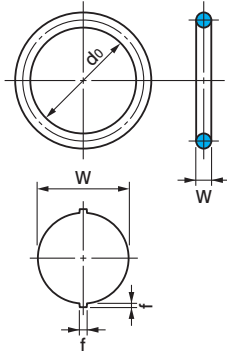

O-Ring Dimensions

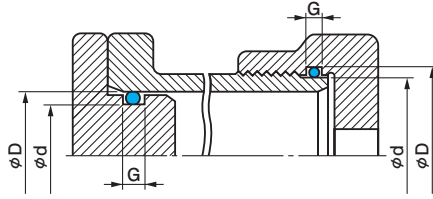

(Extrusion clearance: Refer to Fig.1-3 on page 15.)

For Cylindrical Surface Static Applications

G Series

Type Dimension code	NOK part number						JIS dimension identification code		O-ring dimensions							
	Material code						Take the material code to the left and substitute it for the "□" (except for 4C).	(Reference) Old JIS nominal number	Thickness W	Inside diameter do	Tolerance of inside diameter 'do'					
	NBR-70-1	NBR-90	NBR-70-2	FKM-70	FKM-90	4C**					A305 (NBR-70-1) A105 (NBR-90) A122 (NBR-70-2)	F201 (FKM-70) F940 (FKM-90)	Class 4C S503			
	Class 1A A305	Class 1B A105	Class 2 A122	Class 4D F201	F940	Class 4C S503										
CO 00200				R6	N1		OR □ G 25-N	G 25	3.1±0.1	24.4	±0.25	±0.30	±0.37			
CO 00201				U0	V2		OR □ G 30-N	G 30		29.4	±0.29	±0.34	±0.43			
CO 00202				U2	V1		OR □ G 35-N	G 35		34.4	±0.33	±0.39	±0.49			
CO 00203				U2	Z2		OR □ G 40-N	G 40		39.4	±0.37	±0.44	±0.55			
CO 00204				U2	S1		OR □ G 45-N	G 45	44.4	±0.41	±0.49	±0.61				
CO 00205				U0	Z1		OR □ G 50-N	G 50	3.1±0.1	49.4	±0.45	±0.54	±0.67			
CO 00206				R8	V1		OR □ G 55-N	G 55		54.4	±0.49	±0.58	±0.73			
CO 00207				U0	T1		OR □ G 60-N	G 60		59.4	±0.53	±0.63	±0.79			
CO 00208				Q6	H1		OR □ G 65-N	G 65		64.4	±0.57	±0.68	±0.85			
CO 00209				U2	Z0		OR □ G 70-N	G 70	69.4	±0.61	±0.73	±0.91				
CO 00210	A	B	C	U2	W1	L	OR □ G 75-N	G 75	3.1±0.1	74.4	±0.65	±0.78	±0.97			
CO 00211				U2	Z0		OR □ G 80-N	G 80		79.4	±0.69	±0.82	±1.03			
CO 00212				Q1	T1		OR □ G 85-N	G 85		84.4	±0.73	±0.87	±1.09			
CO 00213				U2	Y0		OR □ G 90-N	G 90		89.4	±0.77	±0.92	±1.15			
CO 00214				U2	Y1		OR □ G 95-N	G 95		94.4	±0.81	±0.97	±1.21			
CO 00215							U2	Z0			OR □ G100-N	G 100	99.4	±0.85	±1.02	±1.27
CO 00216			U2	G1		OR □ G105-N	G 105	104.4	±0.87	±1.04	±1.30					
CO 00217			U2	X1		OR □ G110-N	G 110	109.4	±0.91	±1.09	±1.36					
CO 00218			U2	X1		OR □ G115-N	G 115	114.4	±0.94	±1.12	±1.41					
CO 00219			R0	Z0		OR □ G120-N	G 120	119.4	±0.98	±1.17	±1.47					
CO 00220			U2	Z0		OR □ G125-N	G 125	124.4	±1.01	±1.21	±1.51					
CO 00221			U2	H1		OR □ G130-N	G 130	129.4	±1.05	±1.26	±1.57					
CO 00222			U2	G1		OR □ G135-N	G 135	134.4	±1.08	±1.29	±1.62					
CO 00223			X0	Z0		OR □ G140-N	G 140	139.4	±1.12	±1.34	±1.68					
CO 00224			U2	G2		OR □ G145-N	G 145	144.4	±1.16	±1.39	±1.74					
CO 00225	A	B	C	U3	H1	L	OR □ G150-N	G 150	5.7±0.13	149.3	±1.19	±1.42	±1.78			
CO 00226				U3	H0		OR □ G155-N	G 155		154.3	±1.23	±1.47	±1.84			
CO 00227				U3	G1		OR □ G160-N	G 160		159.3	±1.26	±1.51	±1.89			
CO 00228				U3	Z0		OR □ G165-N	G 165		164.3	±1.30	±1.56	±1.95			
CO 00229				U3	W0		OR □ G170-N	G 170		169.3	±1.33	±1.59	±1.99			
CO 00230							U3	V0			OR □ G175-N	G 175	174.3	±1.37	±1.64	±2.05
CO 00231							W0	W1			OR □ G180-N	G 180	179.3	±1.40	±1.68	±2.10
CO 00232							U3	W0			OR □ G185-N	G 185	184.3	±1.44	±1.72	±2.16
CO 00233							U3	V0			OR □ G190-N	G 190	189.3	±1.47	±1.76	±2.20
CO 00234							U3	T0			OR □ G195-N	G 195	194.3	±1.51	±1.81	±2.26
CO 00235							U3	V0			OR □ G200-N	G 200	199.3	±1.55	±1.86	±2.32
CO 01968*							H0	—		—	OR □ G205-N*	G 205*	204.3	±1.58	±1.90	—
CO 00236	B	C	V0	X1	L	OR □ G210-N	G 210	209.3	±1.61	±1.93	±2.41					
CO 03303*	—	—	O0	—	—	OR □ G215-N*	G 215*	214.3	±1.65	±1.98	—					
CO 00237	B	C	U3	Z0	L	OR □ G220-N	G 220	219.3	±1.68	±2.01	±2.52					
CO 02011*	—	—	P0	—	—	OR □ G225-N*	G 225*	224.3	±1.71	±2.05	—					
CO 00238	B	C	U3	W0	L	OR □ G230-N	G 230	229.3	±1.73	±2.07	±2.59					
CO 02031*	—	—	O0	—	—	OR □ G235-N*	G 235*	234.3	±1.78	±2.14	—					
CO 00239	B	C	U3	D0	L	OR □ G240-N	G 240	239.3	±1.81	±2.17	±2.71					
CO 02060*	—	—	G0	—	—	OR □ G245-N*	G 245*	244.3	±1.85	±2.22	—					
CO 00240	B	C	U3	G1	L	OR □ G250-N	G 250	249.3	±1.88	±2.25	±2.82					
CO 02079*	—	—	H0	—	—	OR □ G255-N*	G 255*	254.3	±1.91	±2.29	—					
CO 00241	B	C	U3	Z0	L	OR □ G260-N	G 260	259.3	±1.94	±2.32	±2.91					

*For these code numbers, only rubber materials A305 and F201 are available.

30 **Dimension identification codes for 4C are given as follows: "4C□". Please take the Old JIS nominal number and substitute it for the "□".
 Ex. 3) For parts with an inside diameter of 24.4 and a thickness of 3.1: 4CG25

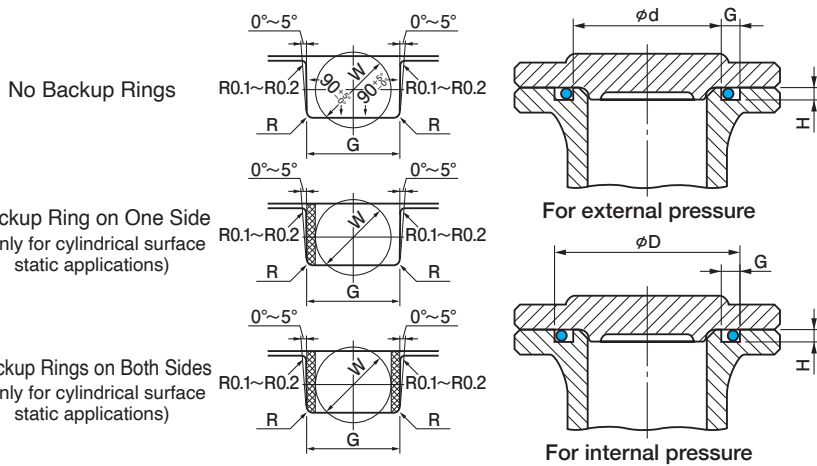

(Note) Chamfering is indicated in accordance with NOK recommended values.

Groove Shapes For Flat Face Static Applications

■ JIS dimension identification codes represent “product type + material specification + dimensional specification + appearance grade.”

■ We also offer parts with the same dimensions as the Old JASO standards in addition to the materials given for the following lineups. Please refer to pages 46 through 53 for more details.

- Class 3 (SBR materials)
- Class 4E (acrylic materials)
- Class 5 (EPDM materials)
- Material H (H-NBR materials)

(Unit: mm)

Groove dimensions (based on JIS standard values)											
Composite burr dimension f	Dimension d		Dimensions D		Dimension G (tolerance $^{+0.25}_0$)			Dimension H	Dimension R	Max. center misalignment (TIR) of D and d for dynamic or cylindrical surface static applications	
	d	Tolerance	D	Tolerance	No backup rings	Backup ring on one side	Backup rings on both sides	H±0.05	Max. value		
0.12 or less	25		30							0.08	
	30		35								
	35		40								
	40		45								
	45		50								
	50		55								
	55		60								
	60		65								
	65		70								
	70		75								
	75		80								
	80	0	85	+0.10	4.1	5.6	7.3	2.4	0.7		
	85	-0.10	90	0							
	90		95								
	95		100								
	100		105								
	105		110								
	110		115								
115		120									
120		125									
125		130									
130		135									
135		140									
140		145									
145		150									
0.16 or less	150		160							0.10	
	155		165								
	160		170								
	165		175								
	170		180								
	175		185								
	180		190								
	185		195								
	190		200								
	195		205								
	200	0	210	+0.10	7.5	9.0	11.5	4.6	0.8		
	205	-0.10	215	0							
	210		220								
	215		225								
	220		230								
	225		235								
	230		240								
	235		245								
240		250									
245		255									
250		260									
255		265									
260		270									

JIS B 2401-1 G Series (Static Applications)

■ When ordering, please make sure to specify both the ① JIS dimension identification code and ② NOK part number.
 Ex.1) If you wish to purchase a part with an inside diameter of 264.3 and thickness of 5.7 made of material NBR-70-1:
 • JIS identification code: OR NBR-70-1 G265-N
 • NOK part number: CO 06543 A
 Ex.2) If you wish to purchase a part with an inside diameter of 264.3 and thickness of 5.7 made of material FKM-70:
 • JIS identification code: OR FKM-70 G265-N
 • NOK part number: CO 06543 H

Material	JIS	NBR-70-1	NBR-90	NBR-70-2	FKM-70	FKM-90	—
	Old JIS*	Class 1A	Class 1B	Class 2	Class 4D	—	Class 4C
	NOK code	A305	A105	A122	F201	F940	S503

*Old JIS: JIS B 2401-2005

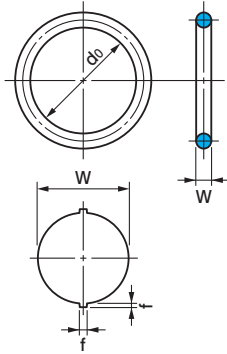

O-Ring Dimensions

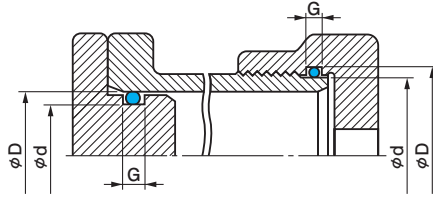

(Extrusion clearance: Refer to Fig.1-3 on page 15.)

For Cylindrical Surface Static Applications

G Series

Type Dimension code	NOK part number						JIS dimension identification code		O-ring dimensions				
	Material code						Take the material code to the left and substitute it for the "□" (except for 4C).	(Reference) Old JIS nominal number	Thickness W	Inside diameter do	Tolerance of inside diameter 'do'		
	NBR-70-1	NBR-90	NBR-70-2	FKM-70	FKM-90	4C**					A305 (NBR-70-1) A105 (NBR-90) A122 (NBR-70-2)	F201 (FKM-70) F940 (FKM-90)	Class 4C S503
	Class 1A A305	Class 1B A105	Class 2 A122	Class 4D F201	F940	Class 4C S503							
CO 06543*	—	—	H0	—	—	—	OR □ G265-N*	G265*	5.7±0.13	264.3	±1.98	±2.38	—
CO 00242	B	C	U3	Z0	L	—	OR □ G270-N	G270		269.3	±2.01	±2.41	±3.01
CO 02100*	—	—	H0	—	—	—	OR □ G275-N*	G275*		274.3	±2.04	±2.45	—
CO 00243	B	C	U3	—	L	—	OR □ G280-N	G280		279.3	±2.07	±2.48	±3.10
CO 03210*	—	—	H0	—	—	—	OR □ G285-N*	G285*		284.3	±2.11	±2.53	—
CO 00244	B	C	U3	Y0	L	—	OR □ G290-N	G290		289.3	±2.14	±2.56	±3.21
CO 06566*	—	—	P0	—	—	—	OR □ G295-N*	G295*		294.3	±2.17	±2.60	—
CO 00245	B	C	U3	—	L	—	OR □ G300-N	G300		299.3	±2.20	±2.64	±3.30
DO 01137*	—	—	—	—	—	—	OR □ G305-N*	G305*		304.3	±2.24	±2.69	—
CO 02158*	—	—	—	—	—	—	OR □ G310-N*	G310*		309.3	±2.27	±2.72	—
CO 08811*	—	—	—	—	—	—	OR □ G315-N*	G315*		314.3	±2.30	±2.76	—
CO 02176*	—	—	—	—	—	—	OR □ G320-N*	G320*		319.3	±2.33	±2.80	—
CO 08812*	—	—	—	—	—	—	OR □ G325-N*	G325*		324.3	±2.36	±2.83	—
CO 08813*	—	—	—	—	—	—	OR □ G330-N*	G330*		329.3	±2.39	±2.87	—
CO 08814*	—	—	—	—	—	—	OR □ G335-N*	G335*		334.3	±2.42	±2.90	—
CO 02206*	—	—	—	—	—	—	OR □ G340-N*	G340*	339.3	±2.45	±2.94	—	
CO 02216*	—	—	—	—	—	—	OR □ G345-N*	G345*	344.3	±2.48	±2.98	—	
CO 02223*	—	—	—	—	—	—	OR □ G350-N*	G350*	349.3	±2.51	±3.01	—	
CO 08815*	—	—	—	—	—	—	OR □ G355-N*	G355*	354.3	±2.54	±3.05	—	
CO 02244*	—	—	—	—	—	—	OR □ G360-N*	G360*	359.3	±2.57	±3.08	—	
CO 08816*	—	—	—	—	—	—	OR □ G365-N*	G365*	364.3	±2.60	±3.12	—	
CO 08817*	—	—	—	—	—	—	OR □ G370-N*	G370*	369.3	±2.63	±3.16	—	
CO 08818*	—	—	—	—	—	—	OR □ G375-N*	G375*	374.3	±2.67	±3.20	—	
CO 02272*	—	—	—	—	—	—	OR □ G380-N*	G380*	379.3	±2.70	±3.24	—	
CO 08819*	A	—	—	—	—	—	OR □ G385-N*	G385*	384.3	±2.73	±3.28	—	
CO 02287*	—	—	—	—	—	—	OR □ G390-N*	G390*	389.3	±2.77	±3.32	—	
CO 08820*	—	—	—	—	—	—	OR □ G395-N*	G395*	394.3	±2.79	±3.35	—	
CO 02301*	—	—	—	GO	—	—	OR □ G400-N*	G400*	399.3	±2.82	±3.38	—	
CO 08821*	—	—	—	—	—	—	OR □ G405-N*	G405*	404.3	—	—	—	
CO 08822*	—	—	—	—	—	—	OR □ G410-N*	G410*	409.3	—	—	—	
CO 02336*	—	—	—	—	—	—	OR □ G415-N*	G415*	414.3	—	—	—	
CO 08823*	—	—	—	—	—	—	OR □ G420-N*	G420*	419.3	—	—	—	
CO 02358*	—	—	—	—	—	—	OR □ G425-N*	G425*	424.3	±3.00	±3.60	—	
CO 08824*	—	—	—	—	—	—	OR □ G430-N*	G430*	429.3	—	—	—	
CO 08825*	—	—	—	—	—	—	OR □ G435-N*	G435*	434.3	—	—	—	
CO 08826*	—	—	—	—	—	—	OR □ G440-N*	G440*	439.3	—	—	—	
CO 08827*	—	—	—	—	—	—	OR □ G445-N*	G445*	444.3	—	—	—	
CO 02417*	—	—	—	—	—	—	OR □ G450-N*	G450*	449.3	—	—	—	
CO 08828*	—	—	—	—	—	—	OR □ G455-N*	G455*	454.3	—	—	—	
CO 02441*	—	—	—	—	—	—	OR □ G460-N*	G460*	459.3	—	—	—	
CO 06715*	—	—	—	—	—	—	OR □ G465-N*	G465*	464.3	—	—	—	
CO 02460*	—	—	—	—	—	—	OR □ G470-N*	G470*	469.3	—	—	—	
CO 08829*	—	—	—	—	—	—	OR □ G475-N*	G475*	474.3	±3.30	±4.00	—	
CO 08830*	—	—	—	—	—	—	OR □ G480-N*	G480*	479.3	—	—	—	
CO 08831*	—	—	—	—	—	—	OR □ G485-N*	G485*	484.3	—	—	—	
CO 08832*	—	—	—	—	—	—	OR □ G490-N*	G490*	489.3	—	—	—	
CO 08833*	—	—	—	—	—	—	OR □ G495-N*	G495*	494.3	—	—	—	
CO 08834*	—	—	—	—	—	—	OR □ G500-N*	G500*	499.3	—	—	—	

*For these code numbers, only rubber materials A305 and F201 are available.

32 **Dimension identification codes for 4C are given as follows: "4C□". Please take the Old JIS nominal number and substitute it for the "□".
 Ex. 3) For parts with an inside diameter of 269.3 and a thickness of 5.7: 4CG270

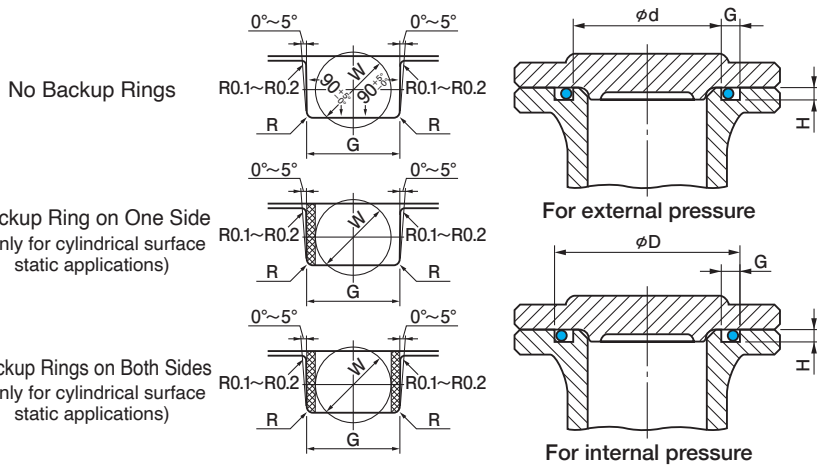

(Note) Chamfering is indicated in accordance with NOK recommended values.

Groove Shapes For Flat Face Static Applications

■ JIS dimension identification codes represent “product type + material specification + dimensional specification + appearance grade.”

■ We also offer parts with the same dimensions as the Old JASO standards in addition to the materials given for the following lineups. Please refer to pages 46 through 53 for more details.

- Class 3 (SBR materials)
- Class 4E (acrylic materials)
- Class 5 (EPDM materials)
- Material H (H-NBR materials)

(Unit: mm)

Groove dimensions (based on JIS standard values)											
Composite burr dimension f	Dimension d		Dimensions D		Dimension G (tolerance $^{+0.25}_0$)			Dimension H	Dimension R	Max. center misalignment (TIR) of D and d for dynamic or cylindrical surface static applications	
	d	Tolerance	D	Tolerance	No backup rings	Backup ring on one side	Backup rings on both sides	H±0.05	Max. value		
0.16 or less	265		275		7.5	9.0	11.5	4.6	0.8	0.10	
	270		280								
	275		285								
	280		290								
	285		295								
	290		300								
	295		305								
	300		310								
	305		315								
	310		320								
	315		325								
	320		330								
	325		335								
	330		340								
	335		345								
	340		350								
	345		355								
	350		360								
	355		365								
	360		370								
365		375									
370		380									
375		385									
380		390									
385	0 -0.10	395	$+0.10$ 0								
390		400									
395		405									
400		410									
405		415									
410		420									
0.16 or less	415		425								
	420		430								
	425		435								
	430		440								
	435		445								
0.16 or less	440		450								
	445		455								
	450		460								
	455		465								
	460		470								
	465		475								
	470		480								
	475		485								
	480		490								
	485		495								
490		500									
495		505									
500		510									

NOK S Series (Static Applications)

Material (NOK code) A305 F201

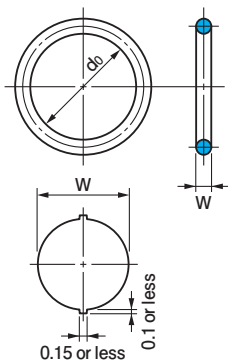

O-Ring Dimensions

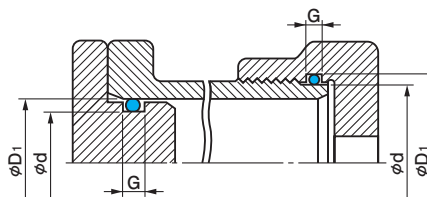

(Extrusion clearance: Refer to Fig.1-3 on page 15.)

For Cylindrical Surface Static Applications

(Unit: mm)

NOK part number		NOK nominal number	O-ring dimensions				Groove dimensions						
Type Dimension code	Material code		Thickness W	Inside diameter d_0	Tolerance of inside diameter ' d_0 '		$d \begin{smallmatrix} 0 \\ -0.05 \end{smallmatrix}$	$D_1 \begin{smallmatrix} +0.05 \\ 0 \end{smallmatrix}$	$D_2 \begin{smallmatrix} +0.05 \\ 0 \end{smallmatrix}$	$G \begin{smallmatrix} +0.25 \\ 0 \end{smallmatrix}$	$H \begin{smallmatrix} 0 \\ -0.1 \end{smallmatrix}$		
	A305				F201	A305						F201	
CO 0500		O3	S 3	1.5±0.1	2.5	±0.24	±0.15	3	5	5.8	2.5	1.0	
CO 0501		P3	S 4		3.5			4	6	6.6			
CO 0502		P3	S 5		4.5			5	7	7.4			
CO 0503		Q2	S 6		5.5			6	8	8.3			
CO 0504		S0	S 7		6.5			7	9	9.3			
CO 0505	A	P0	S 8		7.5			8	10	10.3			
CO 0506		O1	S 9		8.5			9	11	11.3			
CO 0507		O3	S 10		9.5			10	12	12.3			
CO 0508		P2	S 11.2		10.7			11.2	13.2	13.5			
CO 0509		N2	S 12		11.5			12	14	14.3			
CO 0510		Q0	S 12.5		12.0			12.5	14.5	14.8			
CO 0511		R0	S 14		13.5			14	16	16.3			
CO 0512		P2	S 15		14.5			15	17	17.3			
CO 0513		N4	S 16		15.5			16	18	18.3			
CO 0514	R0	S 18	17.5	18	20	20.3							
CO 0515		O2	S 20	2.0±0.1	19.5	±0.3	±0.25	±0.5	20	22	22.3	2.7	1.5
CO 0516		N1	S 22		21.5				22	24	24.3		
CO 0517	A	P2	S 22.4		21.9				22.4	25.4	25.9		
CO 0518		O4	S 24		23.5				24	27	27.5		
CO 0519		U3	S 25		24.5				25	28	28.5		
CO 0520		N2	S 26		25.5				26	29	29.5		
CO 0521		N2	S 28		27.5				28	31	31.5		
CO 0522		Q0	S 29		28.5				29	32	32.5		
CO 0523		P8	S 30		29.5				30	33	33.5		
CO 0524		U3	S 31.5		31.0				31.5	34.5	35		
CO 0525		U3	S 32		31.5				32	35	35.5		
CO 0526	N3	S 34	33.5		34				37	37.5			
CO 0527		P0	S 35		34.5				35	38	38.5		
CO 0528		N0	S 35.5		35.0				35.5	38.5	39		
CO 0529		P0	S 36	35.5	36	39	39.5						
CO 0530		G0	S 38	37.5	38	41	41.5						
CO 0531		U3	S 39	38.5	39	42	42.5						
CO 0532		H0	S 40	39.5	40	43	43.5						
CO 0533		U3	S 42	41.5	42	45	45.5						

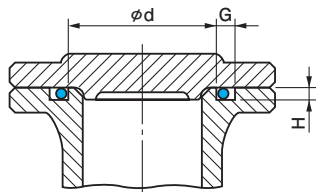

For external pressure

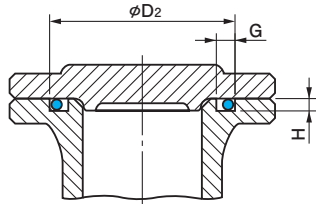

For internal pressure

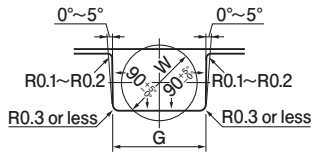

(Note) Chamfering is indicated in accordance with NOK recommended values.

Groove Shapes For Flat Face Static Applications

The NOK S Series is a series of small diameter O-rings that have been specifically designed to meet the demand for use in compact hardware.

■ When ordering, please make sure to specify the NOK part number.

Ex.1) If you wish to purchase a part with an inside diameter of 8.5 and thickness of 1.5 made of material A305:

• NOK part number: **CO 0506 A**
 Type/dimension code | Material code

Ex.2) If you wish to purchase a part with an inside diameter of 8.5 and thickness of 1.5 made of material F201:

• NOK part number: **CO 0506 O1**
 Type/dimension code | Material code

(Unit: mm)

NOK part number		NOK nominal number	O-ring dimensions				Groove dimensions					
Type Dimension code	Material code		Thickness W	Inside diameter d_0	Tolerance of inside diameter 'd ₀ '		d $_{-0.05}^0$	D ₁ $_{0}^{+0.05}$	D ₂ $_{0}^{+0.05}$	G $_{0}^{+0.25}$	H $_{-0.1}^0$	
	A305				F201	A305						F201
CO 0534		U3	S 44	2.0±0.1	43.5	±0.25	±0.5	44	47	47.5	2.7	1.5
CO 0535		H0	S 45		44.5			45	48	48.5		
CO 0536		G0	S 46		45.5			46	49	49.5		
CO 0537		G0	S 48		47.5			48	51	51		
CO 0538		U3	S 50		49.5			50	53	53		
CO 0539	A	U3	S 53		52.5			53	56	56		
CO 0540		U3	S 55		54.5			55	58	58		
CO 0541		H0	S 56		55.5			56	59	59		
CO 0542		G0	S 60		59.5			60	63	63		
CO 0543		G0	S 63		62.5			63	66	66		
CO 0544		P0	S 65		64.5			65	68	68		
CO 0545	U3	S 67	66.5		67			70	70			
CO 0546	U3	S 70	69.5		70			73	73			
CO 0547	A	G0	S 71		70.5			71	74	74		
CO 0548		R0	S 75		74.5			75	78	78		
CO 0549		U3	S 80		79.5			80	83	83		
CO 0550		N2	S 85	84.5	85	88	88					
CO 0551		G0	S 90	89.5	90	93	93					
CO 0552		U3	S 95	94.5	95	98	98					
CO 0553	A	G0	S 100	99.5	100	103	103					
CO 0554		N3	S 105	104.5	105	108	108					
CO 0555		U3	S 110	109.5	110	113	113					
CO 0556		N0	S 112	111.5	112	115	115					
CO 0557		N1	S 115	114.5	115	118	118					
CO 0558		U3	S 120	119.5	120	123	123					
CO 0559	G0	S 125	124.5	125	128	128						
CO 0560	A	G0	S 130	129.5	130	133	133					
CO 0561		G0	S 132	131.5	132	135	135					
CO 0562		G0	S 135	134.5	135	138	138					
CO 0563		G0	S 140	139.5	140	143	143					
CO 0564		G0	S 145	144.5	145	148	148					
CO 0565		G0	S 150	149.5	150	153	153					

NOK SS Series (Static Applications)

Material (NOK code) A305 F201

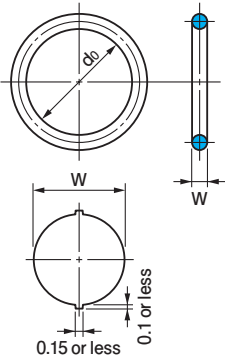

O-Ring Dimensions

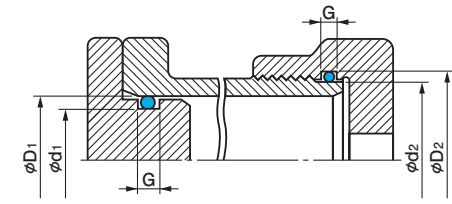

(Extrusion clearance: Refer to Fig. 1-3 on page 15.)

For Cylindrical Surface Static Applications

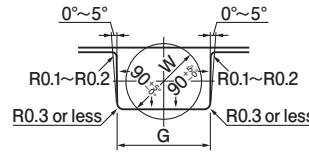

(Note) Chamfering is indicated in accordance with NOK recommended values.

Groove Shapes

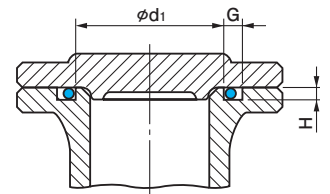

For external pressure

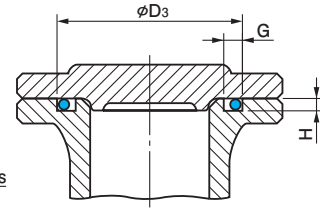

For internal pressure

For Flat Face Static Applications

(Unit: mm)

NOK part number		NOK nominal number	O-ring dimensions				Groove dimensions							
Type Dimension code	Material code		Thickness W	Inside diameter d ₀	Tolerance of inside diameter 'd ₀ '		d ₁ ^{-0.05}	d ₂ ^{-0.05}	D ₁ ^{+0.05}	D ₂ ^{+0.05}	D ₃ ^{+0.05}	G ^{+0.15}	H ^{+0.05}	
	A305				F201	A305								F201
CO 3325		N0	SS 2	1.0±0.07	1.8	±0.15	±0.20	2.0	1.9	3.3	3.3	3.7	1.5	0.7
CO 2956		N1	SS 2.5		2.0			2.5	2.1	3.8	3.5	3.9		
CO 3700		G0	SS 3		2.5			3.0	2.6	4.3	4.0	4.3		
CO 3835		N0	SS 3.5		3.0			3.5	3.1	4.8	4.5	4.7		
DO 1127		G0	SS 4		3.5			4.0	3.6	5.3	5.0	5.1		
CO 7820		N0	SS 4.5		4.0			4.5	4.1	5.8	5.5	5.5		
CO 3729		N0	SS 5		4.5			5.0	4.6	6.3	6.0	6.0		
CO 3370		H0	SS 5.5		5.0			5.5	5.1	6.8	6.5	6.5		
CO 3765		N0	SS 6		5.5			6.0	5.6	7.3	7.0	7.0		
CO 3216		H0	SS 6.5		6.0			6.5	6.1	7.8	7.5	7.5		
CO 8846	A	G0	SS 7		6.5			7.0	6.6	8.3	8.0	8.0		
CO 5497		G0	SS 7.5		7.0			7.5	7.1	8.8	8.5	8.5		
CO 4275		P0	SS 8		7.5			8.0	7.6	9.3	9.0	9.0		
CO 7044		H0	SS 8.5		8.0			8.5	8.1	9.8	9.5	9.5		
CO 4945		G0	SS 9		8.5			9.0	8.6	10.3	10.0	10.0		
CO 7949		G0	SS 9.5	9.0	9.5	9.1	10.8	10.5	10.5					
CO 8847		G0	SS 10	9.5	10.0	9.6	11.3	11.0	11.0					
CO 8848		G0	SS 10.5	10.0	10.5	10.1	11.8	11.5	11.5					
CO 8849		G0	SS 11	10.5	11.0	10.6	12.3	12.0	12.0					
CO 5952		H0	SS 11.5	11.0	11.5	11.1	12.8	12.5	12.5					
CO 8850		G0	SS 12	11.5	12.0	11.6	13.3	13.0	13.0					

The NOK SS Series is a series of small diameter O-rings that have been specifically designed to meet the demand for use in compact hardware.

■ When ordering, please make sure to specify the NOK part number.

Ex.1) If you wish to purchase a part with an inside diameter of 11.5 and thickness of 1.0 made of material A305:
 • NOK part number: **CO 8850 A**
 Type/dimension code | Material code

Ex.2) If you wish to purchase a part with an inside diameter of 11.5 and thickness of 1.0 made of material F201:
 • NOK part number: **CO 8850 G0**
 Type/dimension code | Material code

SS Series

JIS B 2401-1 V Series (Vacuum Flange Applications)

Material	JIS	NBR-70-1	FKM-70
	Old JIS*	Class 1A	Class 4D
	NOK code	A305	F201

*Old JIS: JIS B 2401-2005

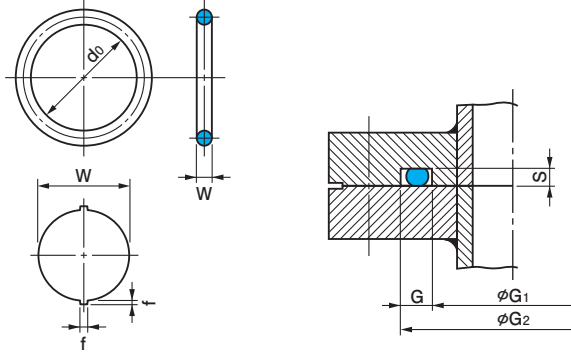

O-Ring Dimensions

(Unit: mm)

NOK part number		JIS dimension identification code			O-ring dimensions				Flange groove dimensions (based on JIS standards)					
Type Dimension code	Material code		Take the material code to the left and substitute it for the "□"	(Reference) Old JIS nominal number	Thickness W	Inside diameter d ₀	Tolerance of inside diameter 'd ₀ '		Composite burr dimension f	Dimension G ₁	Tolerance of G ₁	Dimension G ₂	G ₀ ^{+0.1}	S ₀ ^{-0.2}
	NBR -70-1	FKM -70					A305 (NBR -70-1)	F201 (FKM -70)						
	Class 1A A305	Class 4D F201												
CO 00300	A	U3	OR □ V15 -N	V 15	4.0±0.1	14.5	±0.20	±0.24	0.14 or less	+1.0 0	70	5.0	3.0	
CO 00301		G0	OR □ V24 -N	V 24		23.5	±0.24	±0.28						
CO 00302		G0	OR □ V34 -N	V 34		33.5	±0.33	±0.39						
CO 00303		G0	OR □ V40 -N	V 40		39.5	±0.37	±0.44						
CO 00304		G0	OR □ V55 -N	V 55		54.5	±0.49	±0.58						
CO 00305	A	H0	OR □ V70 -N	V 70	4.0±0.1	69.0	±0.61	±0.73	0.14 or less	+1.0 0	70	5.0	3.0	
CO 00306		G0	OR □ V85 -N	V 85		84.0	±0.72	±0.86						
CO 00307		H0	OR □ V100-N	V100		99.0	±0.83	±0.99						
CO 00308		U3	OR □ V120-N	V120		119.0	±0.97	±1.16						
CO 00309		U3	OR □ V150-N	V150		148.5	±1.18	±1.41						
CO 00310	A	P0	OR □ V175-N	V 175	6.0±0.15	173.0	±1.36	±1.63	0.16 or less	+1.5 0	175	8.0	4.5	
CO 00311		U3	OR □ V225-N	V 225		222.5	±1.70	±2.04						
CO 00312		G0	OR □ V275-N	V 275		272.0	±2.02	±2.42						
CO 00313		G0	OR □ V325-N	V 325		321.5	±2.34	±2.80						
CO 00314		G0	OR □ V380-N	V 380		376.0	±2.68	±3.21						
CO 00315	P0	OR □ V430-N	V 430	425.5	±2.99	±3.58								
CO 00316	A	G0	OR □ V480-N	V 480	10.0±0.3	475.0	±3.30	±3.96	0.18 or less	+2.0 0	480	12.0	7.0	
CO 00317		Q0	OR □ V530-N*	V 530*		524.5	±3.60	±4.32						
CO 00318		G0	OR □ V585-N*	V 585*		579.0	±3.92	±4.70						
CO 00319			OR □ V640-N*	V 640*		633.5	±4.24	±5.08						
CO 00320			OR □ V690-N*	V 690*		683.0	±4.54	±5.44						
CO 00321	A	G0	OR □ V740-N*	V 740*	10.0±0.3	732.5	±4.83	±5.79	0.18 or less	+2.0 0	740	12.0	7.0	
CO 00322		OR □ V790-N*	V 790*	782.0		±5.12	±6.14							
CO 00323		OR □ V845-N*	V 845*	836.5		±5.44	±6.52							
CO 00324		OR □ V950-N*	V 950*	940.5		±6.06	±7.27							
CO 00325		OR □ V1055-N*	V 1055*	1044.0		±6.67	±8.00							

*These code numbers indicate parts equivalent to the JIS B 2401-1 V Series.

■ When ordering, please make sure to specify both the ① JIS dimension identification code and ② NOK part number. Ex.) If you wish to purchase a part with an inside diameter of 99.0 and thickness of 4.0 made of material NBR-70-1:
 • JIS identification code: OR NBR-70-1 V100-N
 • NOK part number: CO 00307 A

■ JIS dimension identification codes represent "product type + material specification + dimensional specification + appearance grade."

Old ARP568 AS568 Series (Static Applications, AN6227 for Dynamic Applications) (O-Ring Hydraulic Applications for Use in Aircraft)

Material (NOK code) A305 A105 F201

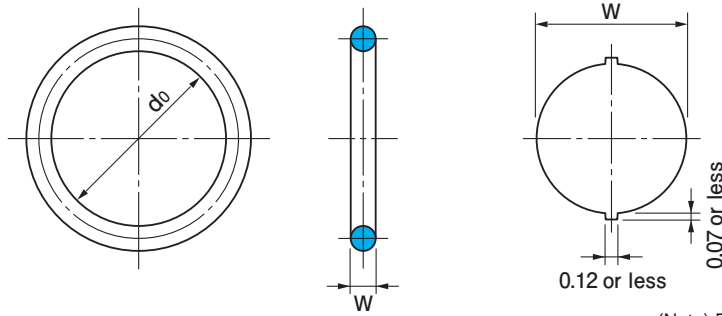

(Note) Produced using the same thickness W, inside diameter d0 tolerance, and residual burr dimensions as the Old JIS W 1516 and 1517.

(Unit: mm)

NOK part number				AS568 (Old ARP568) nominal number	Old AN6227 Old JIS W 1516 nominal number	Old AN6230 Old JIS W 1517 nominal number	O-ring dimensions			
Type Dimension code	Material code						Thickness W	Inside diameter d ₀	Tolerance of inside diameter 'd ₀ '	
	A305	A105	F201	A305 A105	F201					
CO 8424 CO 3387 CO 3388			H0 H0 H0	001 002 003			1.02±0.07 1.27±0.07 1.52±0.07	0.74 1.07 1.42	± 0.10	± 0.10
CO 5146 CO 3052			O0 N0	004 005				1.78 2.57		
CO 0400 CO 0401 CO 0402 CO 0403 CO 0404			H0 H0 O0 H0 G0	006 007 008 009 010	1 2 3 4 5			2.90 3.68 4.47 5.28 6.07		± 0.12
CO 0405 CO 0407			G0 O4	011 012	6 7			7.65 9.25	± 0.12	
CO 3174 CO 1119 CO 1140 CO 3035 CO 1179			N0 X0 G0 O0 G0	013 014 015 016 017				10.82 12.42 14.00 15.60 17.17		± 0.17
CO 1203			O0	018				18.77		± 0.22
CO 1225 CO 1241 CO 3037 CO 4368 CO 3173	A	B	N0 N0 N0 O0 G0	019 020 021 022 023				20.35 21.95 23.52 25.12 26.70	± 0.15	± 0.25
CO 1302 CO 3636 CO 3093 CO 7771 CO 3092			G0 G0 G0 G0 G0	024 025 026 027 028			1.78±0.07	28.30 29.87 31.47 33.05 34.65		± 0.27
CO 6134 CO 3191 CO 5191 CO 3235 CO 5346			H0 G0 H0 G0 H0	029 030 031 032 033				37.82 41.00 44.17 47.35 50.52	± 0.25	± 0.38
CO 1467 CO 7772 CO 4714 CO 8462 CO 8231			G0 G0 G0 G0 G0	034 035 036 037 038				53.70 56.87 60.05 63.22 66.40		± 0.45
CO 4699 CO 4457 CO 7129 CO 4335 CO 3010			G0 G0 G0 G0 H0	039 040 041 042 043				69.57 72.75 75.92 82.27 88.62	± 0.38	± 0.60
CO 8205 CO 4251 CO 4873 CO 4947			G0 G0 G0 N0	044 045 046 047				94.97 101.32 107.67 114.02		± 0.68 ± 0.76

■ When ordering, please make sure to specify the NOK part number.

Ex.1) If you wish to purchase a part with an inside diameter of 2.9 and thickness of 1.78 made of material A305:

• NOK part number: **CO 0400 A**
Type/dimension code Material code

Ex.2) If you wish to purchase a part with an inside diameter of 2.9 and thickness of 1.78 made of material F201:

• NOK part number: **CO 0400 H0**
Type/dimension code Material code

■ Please refer to pages 16 through 17 and page 75 for details on groove shapes.

(Unit: mm)

NOK part number				AS568 (Old ARP568) nominal number	Old AN6227 Old JIS W 1516 nominal number	Old AN6230 Old JIS W 1517 nominal number	O-ring dimensions				
Type Dimension code	Material code						Thickness W	Inside diameter do	Tolerance of inside diameter 'do'		
	A305	A105	F201	A305 A105	F201						
CO 4252	A	B	G0	048			120.37	± 0.38	± 0.76		
CO 8463			G0	049		1.78±0.07	126.72	± 0.58	± 0.93		
CO 4948			N0	050							
CO 8485	A	B	G0	102			1.24	± 0.12			
CO 8464			G0	103		2.06					
CO 8465			G0	104		2.84					
CO 8466			G0	105		3.63					
CO 8467			G0	106		4.42					
CO 6006			G0	107		5.23					
CO 8468			G0	108		6.02					
CO 3084			O0	109		7.59					
CO 0406			R0	110	8	9.19	± 0.17				
CO 0408			P0	111	9	10.77					
CO 0409			U3	112	10	12.37					
CO 0410			P2	113	11	13.94					
CO 0411			U3	114	12	15.54					
CO 0412			R0	115	13	17.12	± 0.22				
CO 0414			N2	116	14	18.72					
CO 4370			A	B	H0	117			20.29	± 0.25	
CO 1240					G0	118		21.89			
CO 6065					G0	119		23.46			
CO 3805					N0	120		25.07			
CO 3601					H0	121		26.64			
CO 4128					H0	122		28.24	± 0.15		
CO 3105					G0	123		29.82			
CO 3112					G0	124		31.42			
CO 3230					G0	125		32.99			
CO 3449					U3	126		34.59			
CO 1367					G0	127		36.17	± 0.30		
CO 1380					G0	128		37.77			
CO 3851					G0	129		39.34			
CO 4408					G0	130		40.94			
CO 6151					G0	131		42.52			
CO 6155	G0	132				44.12	± 0.38				
CO 3152	G0	133				45.69					
CO 1433	G0	134				47.29					
CO 8469	G0	135				48.90					
CO 4330	H0	136				50.47					
CO 1461	G0	137		52.07	± 0.25						
CO 3707	G0	138		53.64							
CO 6189	G0	139		55.24							
CO 3107	H0	140		56.82							
CO 6202	N0	141		58.42							
CO 6210	G0	142		59.99	± 0.50						
CO 7872	G0	143		61.59							
CO 4253	N0	144		63.17							

AS568 Series

Old ARP568 AS568 Series (Static Applications, AN6227 for Dynamic Applications) (O-Ring Hydraulic Applications for Use in Aircraft)

Material (NOK code) A305 A105 F201

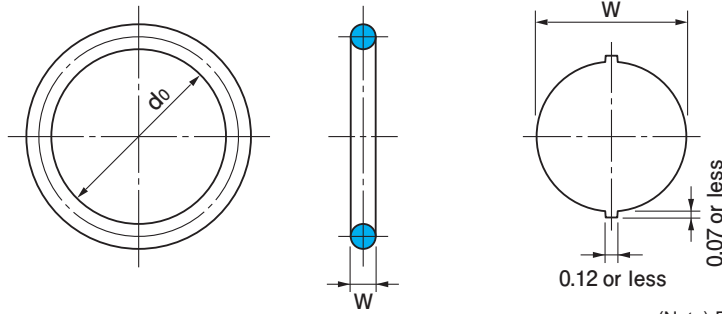

(Note) Produced using the same thickness W, inside diameter d0 tolerance, and residual burr dimensions as the Old JIS W 1516 and 1517.

(Unit: mm)

NOK part number				AS568 (Old ARP568) nominal number	Old AN6227 Old JIS W 1516 nominal number	Old AN6230 Old JIS W 1517 nominal number	O-ring dimensions				
Type Dimension code	Material code						Thickness W	Inside diameter d0	Tolerance of inside diameter 'd0'		
	A305	A105	F201	A305 A105	F201						
CO 1518 CO 3148	A	B	G0	145			2.62±0.07	64.77	± 0.25	± 0.50	
			G0	146				66.34			
CO 3103 CO 4718			G0	147				67.94	± 0.55		
			H0	148				69.52			
CO 6254 CO 6261			G0	149				71.12	± 0.60		
			G0	150				72.69			
CO 6268			G0	151				75.87	± 0.71		
CO 6276 CO 3568			G0	152				82.22			
			G0	153				88.57	± 0.38		
CO 4837 CO 7031			G0	154				94.92			
			G0	155				101.27	± 0.76		
CO 1640			G0	156				107.62			
CO 5357 CO 6356			G0	157				113.97	± 0.88		
			H0	158				120.32			
CO 7811			H0	159				126.67	± 0.58		
CO 1720 CO 4812			G0	160				133.02			
			H0	161				139.37	± 1.01		
CO 7130 CO 1808			G0	162				145.72			
			G0	163				152.07	± 1.14		
CO 1830			G0	164				158.42			
CO 5411 CO 6432	G0	165	164.77	± 0.76							
	G0	166	171.12								
CO 6437	G0	167	177.47	± 1.27							
CO 6445 CO 8470	G0	168	183.82								
	G0	169	190.17	± 1.39							
CO 5303 CO 7775	G0	170	196.52								
	G0	171	202.87	± 0.12							
CO 5270	G0	172	209.22								
CO 7776 CO 8187	G0	173	215.57	± 0.17							
	G0	174	221.92								
CO 8534 DO 1122	G0	175	228.27	± 0.22							
	G0	176	234.62								
DO 1123	G0	177	240.97	± 0.25							
DO 1124	G0	178	247.32								
CO 8471 CO 8472	A	B	G0	201			3.53±0.10	4.34	± 0.12	± 0.12	
			G0	202				5.94			
CO 4527 CO 7048			X0	203				7.52			
			G0	204				9.12			
CO 7049			G0	205				10.69			
CO 8460 CO 7059			G0	206				12.29			± 0.17
			H0	207				13.87			
CO 5250 CO 8461			G0	208				15.47			± 0.22
			G0	209				17.04			
CO 0413 CO 0415			G0	210				18.64			± 0.15
	P0	211	20.22								
CO 0416	P0	212	21.82								
CO 0417	O0	213	23.39								

■ When ordering, please make sure to specify the NOK part number.

Ex.1) If you wish to purchase a part with an inside diameter of 69.52 and thickness of 2.62 made of material A305:

• NOK part number: **CO 4718 A**
Type/dimension code Material code

Ex.2) If you wish to purchase a part with an inside diameter of 69.52 and thickness of 2.62 made of material F201:

• NOK part number: **CO 4718 G0**
Type/dimension code Material code

■ Please refer to pages 16 through 17 and page 75 for details on groove shapes.

(Unit: mm)

NOK part number				AS568 (Old ARP568) nominal number	Old AN6227 Old JIS W 1516 nominal number	Old AN6230 Old JIS W 1517 nominal number	O-ring dimensions		
Type Dimension code	Material code						Thickness W	Inside diameter do	Tolerance of inside diameter 'do'
	A305	A105	F201	A305 A105	F201				
CO 0418			O3	214	19		24.99		
CO 0419			P4	215	20		26.57		± 0.25
CO 0420			R0	216	21		28.17		
CO 0421			U3	217	22		29.74		
CO 0422			N0	218	23		31.34	± 0.15	± 0.30
CO 0423			R0	219	24		32.92		
CO 0424			P0	220	25		34.52		
CO 0425			U3	221	26		36.09		
CO 0426			Q0	222	27		37.69		
CO 0350			O0	223		1	40.87		± 0.38
CO 0351			Q0	224		2	44.04		
CO 0352			O3	225		3	47.22		
CO 0353			R0	226		4	50.39		± 0.45
CO 0354			Q0	227		5	53.57	± 0.25	
CO 0355			U3	228		6	56.74		
CO 0356			R0	229		7	59.92		± 0.50
CO 0357			U3	230		8	63.09		
CO 0358			U3	231		9	66.27		
CO 0359			P0	232		10	69.44		
CO 0360			U3	233		11	72.62		
CO 0361			U3	234		12	75.79		
CO 0362			U3	235		13	78.97		
CO 0363			P0	236		14	82.14		± 0.60
CO 0364	A	B	O0	237		15	85.32		
CO 0365			Q0	238		16	88.49		
CO 0366			U3	239		17	91.67		
CO 0367			N1	240		18	94.84		
CO 0368			R0	241		19	98.02	± 0.38	± 0.71
CO 0369			U3	242		20	101.19		
CO 0370			U3	243		21	104.37		
CO 0371			U3	244		22	107.54		
CO 0372			U3	245		23	110.72		
CO 0373			U3	246		24	113.89		± 0.76
CO 0374			U3	247		25	117.07		
CO 1672			U3	248		26	120.24		
CO 1680			U3	249		27	123.42		
CO 1691			U3	250		28	126.59		
CO 1705			U3	251		29	129.77		
CO 1717			N0	252		30	132.94		
CO 4047			U3	253		31	136.12		± 0.88
CO 1744			G0	254		32	139.29		
CO 1762			U3	255		33	142.47		
CO 1774			G0	256		34	145.64	± 0.58	
CO 1786			U3	257		35	148.82		
CO 1805			Q0	258		36	151.99		
CO 1829			U3	259		37	158.34		
CO 1856			U3	260		38	164.69		± 1.01
CO 1880			U3	261		39	171.04		

AS568 Series

Old ARP568 AS568 Series (Static Applications, AN6227 for Dynamic Applications) (O-Ring Hydraulic Applications for Use in Aircraft)

Material (NOK code) A305 A105 F201

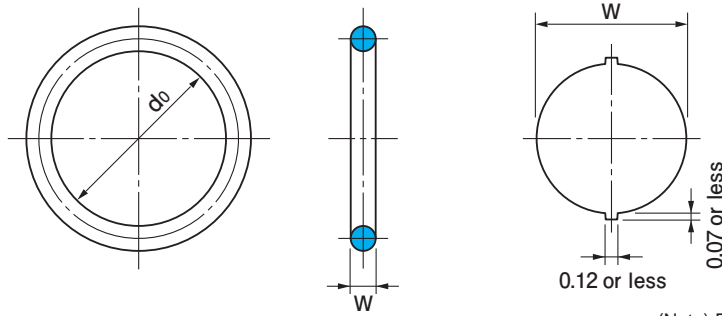

(Note) Produced using the same thickness W, inside diameter d0 tolerance, and residual burr dimensions as the Old JIS W 1516 and 1517.

(Unit: mm)

NOK part number				AS568 (Old ARP568) nominal number	Old AN6227 Old JIS W 1516 nominal number	Old AN6230 Old JIS W 1517 nominal number	O-ring dimensions			
Type Dimension code	Material code						Thickness W	Inside diameter d ₀	Tolerance of inside diameter 'd ₀ '	
	A305	A105	F201	A305 A105	F201					
CO 1893	A	B	U3	262		40	3.53±0.10	177.39	± 0.58	± 1.01
CO 1915			U3	263	41	183.74				
CO 1931			U3	264	42	190.09				
CO 1946			U3	265	43	196.44			± 1.14	
CO 1959			U3	266	44	202.79				
CO 1979			U3	267	45	209.14				
CO 1990			U3	268	46	215.49				
CO 2001			U3	269	47	221.84			± 1.27	
CO 2018			G0	270	48	228.19				
CO 2032			G0	271	49	234.54				
CO 2050			G0	272	50	240.89			± 0.76	
CO 2064			G0	273	51	247.24				
CO 3415			G0	274	52	253.59			± 1.39	
CO 5748				N0	275	266.29				
CO 5393				G0	276	278.99				
CO 2132				G0	277	291.69				
CO 4602				G0	278	304.39				
CO 2192				G0	279	329.79			± 1.65	
CO 4549				G0	280	355.19				
CO 2277				G0	281	380.59				
CO 4609				G0	282	405.26			± 1.90	
CO 6675				H0	283	430.66			± 1.14	
CO 5011				G0	284	456.06			± 2.03	
CO 8486	A	B	G0	309			5.33±0.12	10.46		± 0.12
CO 8487			G0	310		12.06				
CO 8488			O0	311		13.64			± 0.17	
CO 4082			G0	312		15.24			± 0.12	
CO 8480			O0	313		16.81			± 0.22	
CO 8481			G0	314		18.42				
CO 7777			G0	315		19.99				
CO 8482			G0	316		21.59			± 0.25	
CO 6064			G0	317		23.16				
CO 3025			G0	318		24.76				
CO 8483			G0	319		26.34			± 0.15	
CO 4337			O0	320		27.94				
CO 7778			G0	321		29.51				
CO 4081			G0	322		31.12			± 0.30	
CO 8484			G0	323		32.69				
CO 4070			G0	324		34.29				
CO 0427				G0	325	37.46				
CO 0428				U3	326	40.64				
CO 0429				G0	327	43.82			± 0.38	
CO 0430				P0	328	46.99				
CO 0431				U3	329	50.16			± 0.25	
CO 0432				N0	330	53.34				
CO 0433				U3	331	56.52			± 0.45	

AS568 Series

■ When ordering, please make sure to specify the NOK part number.

Ex.1) If you wish to purchase a part with an inside diameter of 190.09 and thickness of 3.53 made of material A305:

• NOK part number: **CO 1931 A**
Type/dimension code Material code

Ex.2) If you wish to purchase a part with an inside diameter of 190.09 and thickness of 3.53 made of material F201:

• NOK part number: **CO 1931 U3**
Type/dimension code Material code

■ Please refer to pages 16 through 17 and page 75 for details on groove shapes.

(Unit: mm)

NOK part number				AS568 (Old ARP568) nominal number	Old AN6227 Old JIS W 1516 nominal number	Old AN6230 Old JIS W 1517 nominal number	O-ring dimensions			
Type Dimension code	Material code						Thickness W	Inside diameter do	Tolerance of inside diameter 'do'	
	A305	A105	F201	A305 A105	F201					
CO 0434			N0	332	35		59.69	± 0.25	± 0.45	
CO 0435			U3	333	36		62.86		± 0.50	
CO 0436			N0	334	37		66.04			
CO 0437			U3	335	38		69.22	± 0.60		
CO 0438			O2	336	39		72.39			
CO 0439			U3	337	40		75.56			
CO 0440			N0	338	41		78.74			
CO 0441			P0	339	42		81.92			
CO 0442			N0	340	43		85.09		± 0.38	
CO 0443			U3	341	44		88.26			
CO 0444			G0	342	45		91.44			
CO 0445			O3	343	46		94.62			
CO 0446			U3	344	47		97.79			
CO 0447			U3	345	48		100.96	± 0.76		
CO 0448			P0	346	49		104.14			
CO 0449			U3	347	50		107.32			
CO 0450			U3	348	51		110.49			
CO 0451			U3	349	52		113.66			
CO 6340	A	B	U3	350			116.84	5.33±0.12		
CO 7779			G0	351			120.02			
CO 4133			G0	352			123.19			
CO 6366			G0	353			126.36			
CO 4205			G0	354			129.54		± 0.93	
CO 5131			H0	355			132.72			
CO 6385			G0	356			135.89			
CO 5317			U3	357			139.07			
CO 7782			G0	358			142.24			
CO 4111			N0	359			145.42			± 0.58
CO 8429			G0	360			148.59			
CO 7783			G0	361			151.77			
CO 7784			G0	362			158.12			
CO 7785			G0	363			164.47			
CO 7786			G0	364			170.82		± 1.01	
CO 7787			G0	365			177.17			
CO 7819			H0	366			183.52		± 1.14	
CO 3417			G0	367			189.86			
CO 1945	U3	368			196.22					
CO 7789	G0	369			202.57					
CO 7790	G0	370			208.92					
CO 6492	G0	371			215.27	± 0.76				
CO 7791	G0	372			221.62					
CO 7792	G0	373			227.97					
CO 7793	G0	374			234.32					
CO 8801	G0	375			240.67					
CO 8803	G0	376			247.02	± 1.39				
CO 7794	G0	377			253.37					
CO 4905	N0	378			266.07					
CO 7795	G0	379			278.77					
									± 1.52	

Old ARP568 AS568 Series (Static Applications, AN6227 for Dynamic Applications) (O-Ring Hydraulic Applications for Use in Aircraft)

Material (NOK code) A305 A105 F201

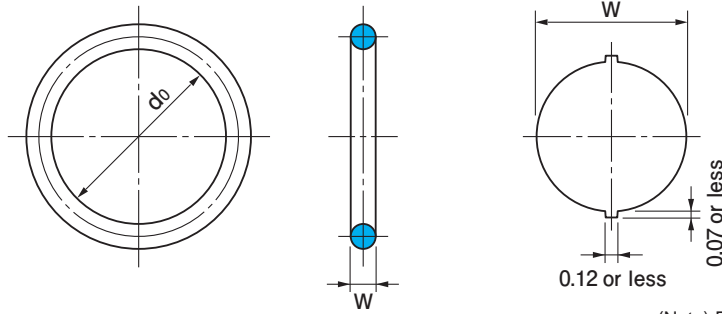

(Note) Produced using the same thickness W, inside diameter d0 tolerance, and residual burr dimensions as the Old JIS W 1516 and 1517.

(Unit: mm)

NOK part number				AS568 (Old ARP568) nominal number	Old AN6227 Old JIS W 1516 nominal number	Old AN6230 Old JIS W 1517 nominal number	O-ring dimensions			
Type Dimension code	Material code						Thickness W	Inside diameter d0	Tolerance of inside diameter 'd0'	
	A305	A105	F201	A305 A105	F201					
CO 8851 CO 4906 CO 7797 CO 7798 CO 6643	A	B	G0	380			5.33±0.12	291.47	± 0.76	± 1.65
			N0	381		304.17				
			G0	382		329.57				
			G0	383		354.97		± 1.77		
			G0	384		380.37				
			G0	385		405.26		± 1.14	± 1.90	
			G0	386		430.66			± 2.03	
			H0	387		456.06			± 2.15	
			G0	388		481.46			± 2.28	
CO 0487 CO 0452 CO 0453 CO 0454 CO 0455	A	B	G0	425	88		6.98±0.15	113.66	± 0.38	± 0.83
			P0	426	53	116.84				
			G0	427	54	120.02				
			G0	428	55	123.19				
			G0	429	56	126.36		± 0.93		
			U3	430	57	129.54				
			G0	431	58	132.72				
			G0	432	59	135.89				
			G0	433	60	139.06				
			G0	434	61	142.24				
			G0	435	62	145.42			± 0.58	
			G0	436	63	148.59				
			U3	437	64	151.76				
			G0	438	65	158.12				
			G0	439	66	164.46		± 1.01		
			G0	440	67	170.82				
			H0	441	68	177.16		± 1.14		
			G0	442	69	183.52				
			G0	443	70	189.86				
			G0	444	71	196.22				
			G0	445	72	202.56		± 1.39		
			G0	446	73	215.26				
			U3	447	74	227.96				
			G0	448	75	240.66				
			G0	449	76	253.36				
			G0	450	77	266.06			± 0.76	
			U3	451	78	278.76				
			G0	452	79	291.46				
			G0	453	80	304.16				
			G0	454	81	316.86		± 1.52		
			U3	455	82	329.56				
			U3	456	83	342.26				
			P0	457	84	354.96				
			G0	458	85	367.66				
			G0	459	86	380.36				
			G0	460	87	393.06		± 1.77		
								± 1.14	± 1.90	
CO 4397 CO 7806					G0	461				
			G0	462				417.96		

AS568 Series

■ When ordering, please make sure to specify the NOK part number.

Ex.1) If you wish to purchase a part with an inside diameter of 380.37 and thickness of 5.33 made of material A305:

• NOK part number: **CO 6643 A**
Type/dimension code Material code

Ex.2) If you wish to purchase a part with an inside diameter of 380.37 and thickness of 5.33 made of material F201:

• NOK part number: **CO 6643 G0**
Type/dimension code Material code

■ Please refer to pages 16 through 17 and page 75 for details on groove shapes.

(Unit: mm)

NOK part number				AS568 (Old ARP568) nominal number	Old AN6227 Old JIS W 1516 nominal number	Old AN6230 Old JIS W 1517 nominal number	O-ring dimensions					
Type Dimension code	Material code						Thickness W	Inside diameter do	Tolerance of inside diameter 'do'			
	A305	A105	F201	A305 A105	F201							
CO 7807	A	B	G0	463			6.98±0.15	430.66	± 1.14	± 2.03		
CO 2401			G0	464				443.36				
CO 7808			G0	465				456.06				
CO 5107			G0	466				468.76				
CO 4270			G0	467				481.46				
CO 8810			G0	468				494.16		± 2.28		
CO 5480	A	B	N0	901				1.42±0.07	± 0.12	4.70	± 0.15	
CO 3091			O0	902				1.63±0.07		6.07		
CO 7600			G0	903						7.64	± 0.17	
CO 3597			N0	904				1.83±0.07		8.92		
CO 1087			G0	905						10.52		
CO 3604			P0	906				1.98±0.07		11.89		
CO 8804			G0	907				2.08±0.07		13.46		
CO 1165			T0	908				2.21±0.07		16.36		
CO 8805			G0	909				2.46±0.07		17.93	± 0.22	
CO 1206			O0	910						19.18		
CO 8234			G0	911				2.95±0.10		21.92	± 0.15	± 0.25
CO 1253			G0	912						23.47		
CO 8806			G0	913						25.04		
CO 2998			G0	914						26.59		
CO 1315			H0	916						29.74		
CO 8807			G0	918						34.42	± 0.30	
CO 3640			G0	920				3.00±0.10		37.46	± 0.25	± 0.35
CO 3706			G0	924						43.69		
CO 8808	G0	928	53.09									
CO 8809	G0	932	59.36	± 0.45								

AS568 Series

Old JASO F 404 Thickness $\phi 1.9$ Series (Static/Dynamic Applications)

Material	JASO	Class 1A	Class 2	Class 3	Class 4C	Class 4D	Class 4E	Class 5	H*
	NOK code	A305	A122	R189	S503	F201	T767	E116	G607

Only the appearance grade differs with the current standards.

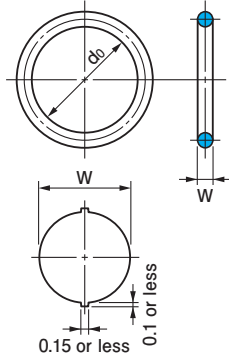

O-Ring Dimensions

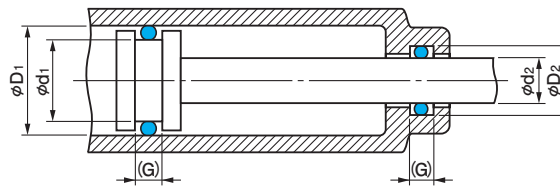

Dynamic Applications

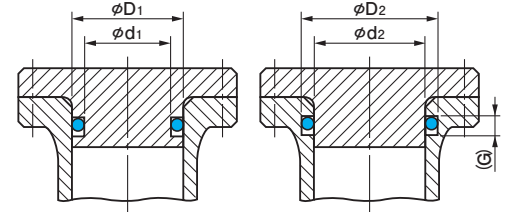

For Cylindrical Surface Static Applications

(Extrusion clearance: Refer to Fig.1-3 on page 15.)

Type Dimension code	NOK part number								NOK nominal number	O-ring dimensions				
	Material code									Thickness W	Inside diameter do	Tolerance of inside diameter 'do'		
	Class 1A	Class 2	Class 3	Class 4C	Class 4D	Class 4E	Class 5	H*				A305 (Class 1A) A122 (Class 2) R189 (Class 3)	S503 (Class 4C) T767 (Class 4E) E116 (Class 5)	F201 (Class 4D) G607 (H*)
A305	A122	R189	S503	F201	T767	E116	G607							
CO 0000					S9	P2	S1	W0	1003	1.9±0.07	2.8			
CO 0001					R4	G4	H1	W0	1004		3.8			
CO 0002					S8	Z3	H1	X2	1005		4.8			
CO 0003					T9	H4	Z1	W0	1006		5.8			
CO 0004					T8	H4	O2	Q1	1007		6.8			
CO 0005					U5	T3	R2	V1	1008		7.8			
CO 0006					Q5	R3	U1	G0	1009		8.8			
CO 0007					U9	S4	O1	Y0	1010		9.8			
CO 0600	A	C	K	L	X0	G2	W0	R0	1011		11.0	±0.12	±0.36	±0.24
CO 0601					S0	G3	Z2	S1	1012		12.3			
CO 0602					T0	G3	Y0	Z0	1013		13.0			
CO 0604					P5	V1	H1	R0	1014		13.8			
CO 0605					N4	H3	R1	Q0	1015		14.8			
CO 0606					Q7	X2	N1	X0	1016		15.8			
CO 0607					O3	Q1	Y0	U0	1017		16.8			
CO 0609					N3	G3	Q1	R1	1018		17.8			
CO 0610					N0	W1	V0	G0	1019		18.8			
CO 0612					O3	H2	R1	V1	1020	19.8				
CO 0613					N4	G2	T0	G0	1021	21.0				
CO 0614					G0	H1	V0	R0	1022	22.1				
CO 0616					N0	G2	Y0	T0	1023	23.3				
CO 0618	A	C	K	L	U3	V0	S0	P0	1025	24.7	±0.15	±0.45	±0.30	
CO 0620					N0	G1	W0	Y0	1026	26.2				
CO 0622					S0	X0	T0	G0	1028	27.7				
CO 0624					N0	U0	S0	O0	1030	29.7				
CO 0626					H0	S0	P0	Q0	1031	31.2				
CO 0628					O0	Z0	V0	W0	1033	33.2				
CO 0630					H0	T0	Q0	R0	1035	35.2				

*Material H is the NOK material code used for H-NBR (hydrogenated nitrile rubber).

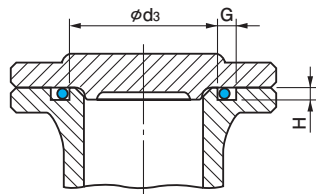

For external pressure

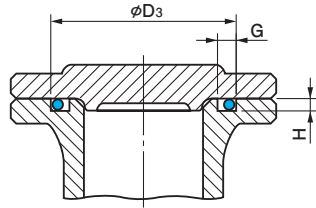

For internal pressure

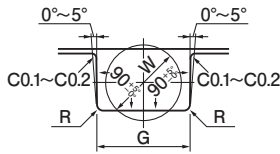

(Note) Chamfering is indicated in accordance with NOK recommended values.

Groove Shapes For Flat Face Static Applications

■ When ordering, please make sure to specify the NOK part number.

Ex.1) If you wish to purchase a part with an inside diameter of 17.8 and thickness of 1.9 made of material Class 1A:

• NOK part number: **CO 0609 A**
 Type/dimension code | Material code

Ex.2) If you wish to purchase a part with an inside diameter of 17.8 and thickness of 1.9 made of material Class 4D:

• NOK part number: **CO 0609 N3**
 Type/dimension code | Material code

*Please note that these parts differ with JIS standard parts in terms of appearance specifications.

*JASO standards do not contain specifications on dimension (G). Please use dimension G in place of dimension (G).

(Unit: mm)

Groove dimensions											
	d ₂ d ₃	d ₁	Tolerances for d ₁ , d ₂ , and d ₃	D ₁	D ₂	D ₃	Tolerances for D ₁ , D ₂ , and D ₃	Dimension G	Dimension H	Dimension R	Max. center misalignment (TIR) of D ₁ and d ₁ or D ₂ and d ₂ for dynamic or cylindrical surface static applications
								G ^{+0.25} ₀	H±0.05	Max. value	
	3	3.1	0 -0.05	6	5.9	6.3	+0.05 0	2.5	1.4	0.4	0.05
	4	4.1		7	6.9	7.3					
	5	5.1		8	7.9	8.3					
	6	6.1		9	8.9	9.3					
	7	7.1		10	9.9	10.3					
	8	8.1		11	10.9	11.3					
	9	9.1		12	11.9	12.3					
	10	10.1	13	12.9	13.3						
	11.2	11.3	14.2	14.1	14.4	+0.06 0	2.5	1.4	0.4	0.05	
	12.5	12.6	15.5	15.4	15.7						
	13.2	13.3	16.2	16.1	16.4						
	14	14.1	17	16.9	17.2						
	15	15.1	18	17.9	18.2						
	16	16.1	19	18.9	19.2						
	17	17.1	20	19.9	20.2						
	18	18.1	21	20.9	21.2	+0.08 0	2.5	1.4	0.4	0.05	
	19	19.1	22	21.9	22.2						
	20	20.1	23	22.9	23.2						
	21.2	21.3	24.2	24.1	24.4						
	22.4	22.5	25.4	25.3	25.5						
	23.6	23.7	26.6	26.5	26.7						
	25	25.1	28	27.9	28.1						
	26.5	26.6	29.5	29.4	29.6						
	28	28.1	31	30.9	31.1						
	30	30.1	33	32.9	33.1						
	31.5	31.6	34.5	34.4	34.6						
	33.5	33.6	36.5	36.4	36.6						
	35.5	35.6	38.5	38.4	38.6						

Old JASO F 404 Thickness $\phi 2.4$ Series (Static/Dynamic Applications)

Material	JASO	Class 1A	Class 2	Class 3	Class 4C	Class 4D	Class 4E	Class 5	H*
	NOK code	A305	A122	R189	S503	F201	T767	E116	G607

Only the appearance grade differs with the current standards.

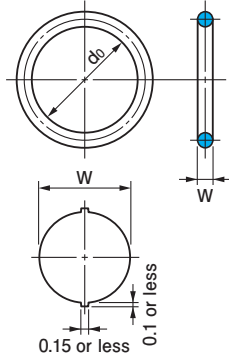

O-Ring Dimensions

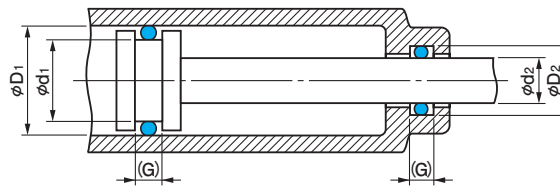

Dynamic Applications

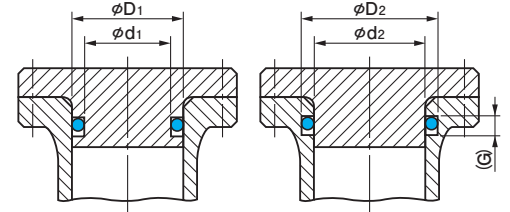

For Cylindrical Surface Static Applications

(Extrusion clearance: Refer to Fig.1-3 on page 15.)

Type Dimension code	NOK part number								NOK nominal number	O-ring dimensions											
	Material code									Thickness W	Inside diameter d_0	Tolerance of inside diameter 'd ₀ '									
	Class 1A A305	Class 2 A122	Class 3 R189	Class 4C S503	Class 4D F201	Class 4E T767	Class 5 E116	H*				A305 (Class 1A) A122 (Class 2) R189 (Class 3)	S503 (Class 4C) T767 (Class 4E) E116 (Class 5)	F201 (Class 4D) G607 (H*)							
CO 0008 CO 0010 CO 0012 CO 0603 CO 0013	A	C	K	L	X9	G5	Y1	T0	2010	2.4±0.07	9.8	±0.12	±0.36	±0.24							
U3					T1	H1	S0	2011	11.0												
Q0					G2	G1	T0	2012	12.3												
H0					T0	P0	Q0	2013	13.0												
X0					G3	G2	Q1	2014	13.8												
U3					G4	Y1	Z0	2015	14.8												
V9					P3	Z1	X0	2016	15.8												
P5					X0	P0	H0	2017	16.8												
T9	R2	G1	X0	2018	17.8																
CO 0611 CO 0017 CO 0018 CO 0615 CO 0617	A	C	K	L	O2	G2	X0	Z0	2019		18.8	±0.15	±0.45	±0.30							
R7					T2	Z1	G0	2020	19.8												
S6					G3	Y1	G0	2021	20.8												
H0					Y0	V0	W0	2022	22.1												
P0					P1	U0	H0	2023	23.3												
U3					H1	Z0	G0	2025	24.7												
N3					H2	W0	R0	2026	26.2												
O3					P2	S1	P1	2028	27.7												
U3					Z0	V0	T0	2030	29.7												
H0					H1	X0	Y0	2031	31.2												
CO 0629 CO 0631 CO 0632 CO 0633					A	C	K	L	O6		Z0				U0	W0	2033	33.2	±0.25	±0.75	±0.50
N3									Z0		V0				Y1	2035	35.2				
R0	Y0	T0	U0	2037					37.2												
U3	G2	Z0	G1	2040					39.7												
CO 0634 CO 0635 CO 0636 CO 0637 CO 0638	A	C	K	L					Q4		Z0	V0	W0	2042	42.2	±0.40	±1.20	±0.80			
O0									Y0	U0	H0	2045	44.7								
P3									Z0	U0	X0	2047	47.2								
G0									X0	T0	U0	2050	49.7								
X0									H1	Z0	H0	2053	52.6								
U0									H1	Y0	G1	2056	55.6								
N1									U0	S0	T0	2060	59.6								
G0									R0	P0	Q0	2063	62.6								
G0					Z0	S0	P0	2067	66.6												
CO 0648					A	C	K	L	P0	V0	U0	S0	2071	70.6	±0.40				±1.20	±0.80	

*Material H is the NOK material code used for H-NBR (hydrogenated nitrile rubber).

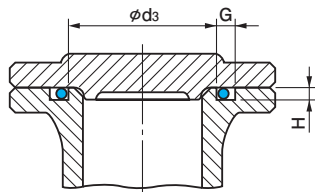

For external pressure

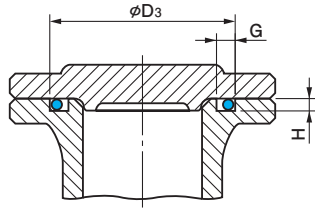

For internal pressure

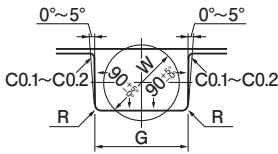

(Note) Chamfering is indicated in accordance with NOK recommended values.

Groove Shapes For Flat Face Static Applications

■ When ordering, please make sure to specify the NOK part number.

Ex.1) If you wish to purchase a part with an inside diameter of 39.7 and thickness of 2.4 made of material Class 1A:

• NOK part number: **CO 0633 A**
 Type/dimension code | Material code

Ex.2) If you wish to purchase a part with an inside diameter of 39.7 and thickness of 2.4 made of material Class 4D:

• NOK part number: **CO 0633 U3**
 Type/dimension code | Material code

*Please note that these parts differ with JIS standard parts in terms of appearance specifications.

*JASO standards do not contain specifications on dimension (G). Please use dimension G in place of dimension (G).

(Unit: mm)

Groove dimensions											
	d ₂ d ₃	d ₁	Tolerances for d ₁ , d ₂ , and d ₃	D ₁	D ₂	D ₃	Tolerances for D ₁ , D ₂ , and D ₃	Dimension G	Dimension H	Dimension R	Max. center misalignment (TIR) of D ₁ and d ₁ or D ₂ and d ₂ for dynamic or cylindrical surface static applications
								G ^{+0.25} ₀	H±0.05	Max. value	
	10 11.2 12.5 13.2 14	10.2 11.4 12.7 13.4 14.2		14 15.2 16.5 17.2 18	13.8 15 16.3 17 17.8	14.1 15.3 16.6 17.3 18.1					
	15 16 17 18	15.2 16.2 17.2 18.2	0 -0.06	19 20 21 22	18.8 19.8 20.8 21.8	19.1 20.1 21.1 22.1	+0.06 0				
	19 20 21 22.4 23.6	19.2 20.2 21.2 22.6 23.8		23 24 25 26.4 27.6	22.8 23.8 24.8 26.2 27.4	23.1 24.1 25.1 26.4 27.6					
	25 26.5 28 30 31.5	25.2 26.7 28.2 30.2 31.7		29 30.5 32 34 35.5	28.8 30.3 31.8 33.8 35.3	29 30.5 32 34 35.5		3.2	1.8	0.4	0.05
	33.5 35.5 37.5 40	33.7 35.7 37.7 40.2	0 -0.08	37.5 39.5 41.5 44	37.3 39.3 41.3 43.8	37.5 39.5 41.5 44	+0.08 0				
	42.5 45 47.5 50 53	42.7 45.2 47.7 50.2 53.2		46.5 49 51.5 54 57	46.3 48.8 51.3 53.8 56.8	46.5 49 51.5 54 57					
	56 60 63 67	56.2 60.2 63.2 67.2	0 -0.10	60 64 67 71	59.8 63.8 66.8 70.8	60 64 67 71	+0.10 0				
	71	71.2		75	74.8	75					

Old JASO F 404 Thickness $\phi 3.1$ Series (Static/Dynamic Applications)

Material	JASO	Class 1A	Class 2	Class 3	Class 4C	Class 4D	Class 4E	Class 5	H*
	NOK code	A305	A122	R189	S503	F201	T767	E116	G607

Only the appearance grade differs with the current standards.

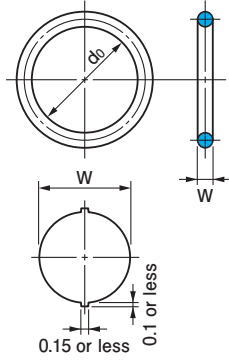

O-Ring Dimensions

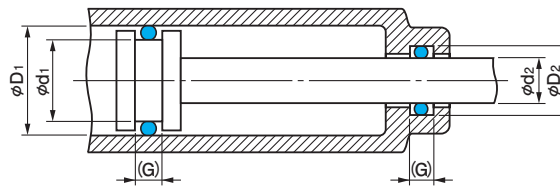

Dynamic Applications

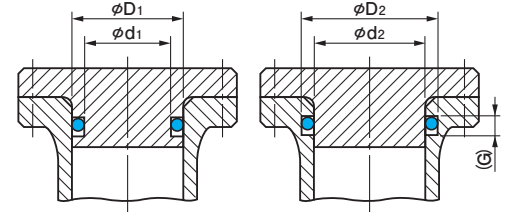

For Cylindrical Surface Static Applications

(Extrusion clearance: Refer to Fig.1-3 on page 15.)

Type Dimension code	NOK part number									NOK nominal number	O-ring dimensions				
	Material code										Thickness W	Inside diameter d_0	Tolerance of inside diameter 'd ₀ '		
	Class 1A	Class 2	Class 3	Class 4C	Class 4D	Class 4E	Class 5	H*	A305 (Class 1A)				S503 (Class 4C)	F201 (Class 4D)	
A305	A122	R189	S503	F201	T767	E116	G607			A122 (Class 2)	T767 (Class 4E)	G607 (H*)			
CO 0200	A	C	K	L	R7	N2	R1	T0	3025 S	3.1 ± 0.10	24.4	±0.15	±0.45	±0.30	
CO 0201					U0	X1	S1	G0	3030 S		29.4				
CO 0202					U3	W1	P1	H0	3035 S		34.4				
CO 0203	A	C	K	L	U3	X1	V1	G1	3040 S		39.4	±0.25	±0.75	±0.50	
CO 0204					U3	T1	Z0	Y0	3045 S		44.4				
CO 0205					U0	H2	Y1	P1	3050 S		49.4				
CO 0206					R9	U2	X1	W1	3055 S		54.4				
CO 0207					U0	N1	X1	W1	3060 S		59.4				
CO 0208					U3	Q7	G2	Z1	X1		3065 S				64.4
CO 0209	U3	O2	S1	Z1								3070 S	69.4		
CO 0210	A	C	K	L	U3	Q2	P2	X1	3075 S	74.4	±0.40	±1.20	±0.80		
CO 0211					U3	X1	W1	Q1	3080 S	79.4					
CO 0212					Q1	T2	Z1	G1	3085 S	84.4					
CO 0213					U3	S1	G1	H0	3090 S	89.4					
CO 0214					U3	P2	G1	Z0	3095 S	94.4					
CO 0215					U3	R1	Q1	H1	Q1	G0				3100 S	99.4
CO 0216	U3	R1	Q1	G0							3105 S	104.4			
CO 0217	U3	H2	H1	Q1							3110 S	109.4			
CO 0218	U3	Q1	W1	G0							3115 S	114.4			
CO 0219	R0	U1	T1	O1							3120 S	119.4			
CO 0220	U3	Q1	X0	G1	3125 S	124.4									
CO 0221	A	C	K	L	U3	G2	N1	S1	3130 S	129.4	±0.60	±1.80	±1.20		
CO 0222					U3	Y1	X1	V1	3135 S	134.4					
CO 0223					X0	S1	X1	H1	3140 S	139.4					
CO 0224					U3	Q1	H1	P1	3145 S	144.4					

*Material H is the NOK material code used for H-NBR (hydrogenated nitrile rubber).

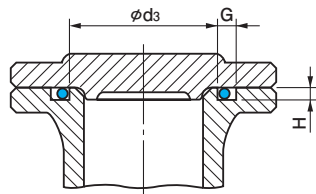

For external pressure

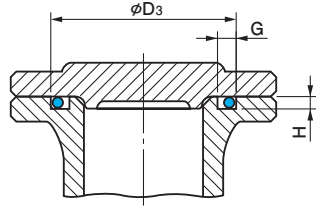

For internal pressure

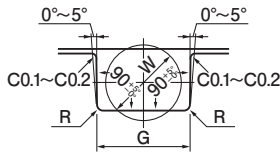

(Note) Chamfering is indicated in accordance with NOK recommended values.

Groove Shapes For Flat Face Static Applications

■ When ordering, please make sure to specify the NOK part number.

Ex.1) If you wish to purchase a part with an inside diameter of 119.4 and thickness of 3.1 made of material Class 1A:

• NOK part number: **CO 0219 A**
 Type/dimension code | Material code

Ex.2) If you wish to purchase a part with an inside diameter of 119.4 and thickness of 3.1 made of material Class 4D:

• NOK part number: **CO 0219 R0**
 Type/dimension code | Material code

*Please note that these parts differ with JIS standard parts in terms of appearance specifications.

*JASO standards do not contain specifications on dimension (G). Please use dimension G in place of dimension (G).

(Unit: mm)

Groove dimensions												
	d_2 d_3	d_1	Tolerances for d_1 , d_2 , and d_3	D_1	D_2	D_3	Tolerances for D_1 , D_2 , and D_3	Dimension G	Dimension H	Dimension R	Max. center misalignment (TIR) of D_1 and d_1 or D_2 and d_2 for dynamic or cylindrical surface static applications	
								$G^{+0.25}_0$	$H \pm 0.05$	Max. value		
	25 30 35	25.3 30.3 35.3	0 -0.08	30.3 35.3 40.3	30.1 35.1 40.1	30.3 35.3 40.3	+0.08 0	4.3	2.4	0.5	0.06	
	40 45 50 55 60	40.3 45.3 50.3 55.3 60.3		45.3 50.3 55.3 60.3 65.3	45.1 50.1 55.1 60.1 65.1	45.3 50.3 55.3 60.3 65.3						
	65 70	65.3 70.3		70.3 75.3	70.1 75.1	70.3 75.3						
	75 80 85 90 95	75.3 80.3 85.3 90.3 95.3		0 -0.10	80.3 85.3 90.3 95.3 100.3	80.1 85.1 90.1 95.1 100.1						80.3 85.3 90.3 95.3 100.3
	100 105 110 115 120	100.3 105.3 110.3 115.3 120.3			105.3 110.3 115.3 120.3 125.3	105.1 110.1 115.1 120.1 125.1						105.3 110.3 115.3 120.3 125.3
	125	125.3			130.3	130.1						130.3
	130 135 140 145	130.3 135.3 140.3 145.3	135.3 140.3 145.3 150.3		135.1 140.1 145.1 150.1	135.3 140.3 145.3 150.3						

Old JASO F 404 Thickness $\phi 3.5$ Series (Static/Dynamic Applications)

Material	JASO	Class 1A	Class 2	Class 3	Class 4C	Class 4D	Class 4E	Class 5	H*
	NOK code	A305	A122	R189	S503	F201	T767	E116	G607

Only the appearance grade differs with the current standards.

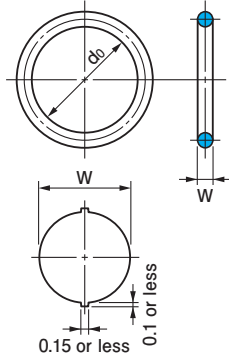

O-Ring Dimensions

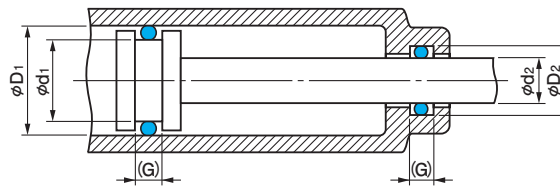

Dynamic Applications

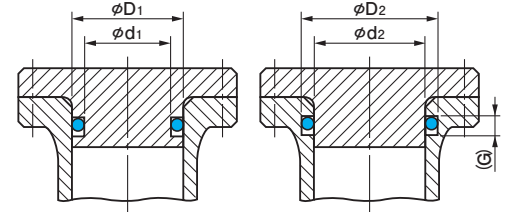

For Cylindrical Surface Static Applications

(Extrusion clearance: Refer to Fig.1-3 on page 15.)

Type Dimension code	NOK part number								NOK nominal number	O-ring dimensions						
	Material code									Thickness W	Inside diameter do	Tolerance of inside diameter 'do'				
	Class 1A	Class 2	Class 3	Class 4C	Class 4D	Class 4E	Class 5	H*				A305 (Class 1A) A122 (Class 2) R189 (Class 3)	S503 (Class 4C) T767 (Class 4E) E116 (Class 5)	F201 (Class 4D) G607 (H*)		
A305	A122	R189	S503	F201	T767	E116	G607									
CO 0021					G0	Y0	R0	S0	3022	3.5 ± 0.10	22.1					
CO 0022					U3	H2	V1	Z0	3024		23.7					
CO 0023					Q0	G2	G1	P1	3025		24.7					
CO 0025					N5	H3	G1	Y0	3026		25.7					
CO 0026					U3	H2	N1	Z0	3028		27.7					
CO 0029	A	C	K	L	S0	G2	G1	G0	3030		29.7	±0.15	±0.45	±0.30		
CO 0031					U3	W0	H0	P0	3031		31.2					
CO 0033					R0	G3	N1	W1	3034		33.7					
CO 0035					U3	V0	Q0	R0	3035		35.2					
CO 0037					Q0	H1	U1	V0	3038		37.7					
CO 0038					U3	G2	X0	G0	3039		38.7					
CO 0039					W0	G2	P1	Z0	3040		39.7					
CO 0041	A	C	K	L	U3	S1	P1	X1	3042		41.7	±0.25	±0.75	±0.50		
CO 0042					U3	G3	G1	G0	3044		43.7					
CO 0043					P4	G2	S1	G1	3045		44.7					
CO 0046					X0	G3	H1	Y1	3048		47.7					
CO 0049					Q6	G2	T1	X1	3050		49.7					
CO 0639					H0	R0	P0	Q0	3053		52.6					
CO 0641	U3	V0	R0	U0	3056	55.6										
CO 0643	O3	S0	Q0	R0	3060	59.6										
CO 0645	U3	V0	S0	O0	3063	62.6										
CO 0647	G0	U0	R0	S0	3067	66.6										
CO 0649	A	C	K	L	U3	V0	Q0	R0	3071	70.6	±0.40				±1.20	±0.80
CO 0650					G0	W0	U0	V0	3075	74.6						
CO 0651					H0	G1	W0	Y0	3080	79.6						
CO 0652					O2	U0	S0	T0	3085	84.6						
CO 0653					U3	W0	U0	V0	3090	89.6						
CO 0654					Q0	U0	S0	T0	3095	94.6						
CO 0655	G0	T0	R0	S0	3100	99.6										
CO 0656	G0	T0	P0	Q0	3106	105.6										
CO 0657	G0	Q0	N0	P0	3112	111.6										
CO 0658	N0	P0	O0	G0	3118	117.6										
CO 0659					G0	R0	P0	Q0	3125	124.6						
CO 0660	A	C	K	L	H0	S0	P0	Q0	3132	131.6		±0.60	±1.80	±1.20		
CO 0661					H0	T0	R0	S0	3140	139.6						
CO 0662					H0	S0	Q0	R0	3150	149.6						

*Material H is the NOK material code used for H-NBR (hydrogenated nitrile rubber).

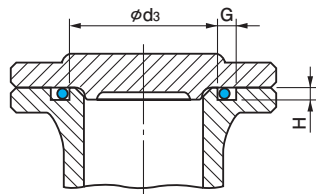

For external pressure

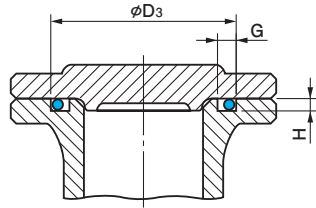

For internal pressure

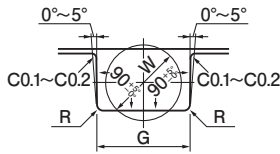

(Note) Chamfering is indicated in accordance with NOK recommended values.

Groove Shapes For Flat Face Static Applications

■ When ordering, please make sure to specify the NOK part number.

Ex.1) If you wish to purchase a part with an inside diameter of 41.7 and thickness of 3.5 made of material Class 1A:

• NOK part number: **CO 0041 A**
 Type/dimension code | Material code

Ex.2) If you wish to purchase a part with an inside diameter of 41.7 and thickness of 3.5 made of material Class 4D:

• NOK part number: **CO 0041 U3**
 Type/dimension code | Material code

*Please note that these parts differ with JIS standard parts in terms of appearance specifications.

*JASO standards do not contain specifications on dimension (G). Please use dimension G in place of dimension (G).

(Unit: mm)

Groove dimensions											
	d ₂ d ₃	d ₁	Tolerances for d ₁ , d ₂ , and d ₃	D ₁	D ₂	D ₃	Tolerances for D ₁ , D ₂ , and D ₃	Dimension G	Dimension H	Dimension R	Max. center misalignment (TIR) of D ₁ and d ₁ or D ₂ and d ₂ for dynamic or cylindrical surface static applications
								G ^{+0.25} ₀	H±0.05	Max. value	
	22.4 24 25 26 28	22.7 24.3 25.3 26.3 28.3		28.4 30 31 32 34	28.1 29.7 30.7 31.7 33.7	28.4 30 31 32 34					
	30 31.5 34 35.5 38	30.3 31.8 34.3 35.8 38.3	0 -0.08	36 37.5 40 41.5 44	35.7 37.2 39.7 41.2 43.7	36 37.5 40 41.5 44	+0.08 0				
	39 40	39.3 40.3		45 46	44.7 45.7	45 46					
	42 44 45 48 50	42.3 44.3 45.3 48.3 50.3		48 50 51 54 56	47.7 49.7 50.7 53.7 55.7	48 50 51 54 56					
	53 56 60 63 67	53.3 56.3 60.3 63.3 67.3		59 62 66 69 73	58.7 61.7 65.7 68.7 72.7	59 62 66 69 73		4.7	2.7	0.7	0.08
	71 75 80 85 90	71.3 75.3 80.3 85.3 90.3	0 -0.10	77 81 86 91 96	76.7 80.7 85.7 90.7 95.7	77 81 86 91 96	+0.10 0				
	95 100 106 112 118	95.3 100.3 106.3 112.3 118.3		101 106 112 118 124	100.7 105.7 111.7 117.7 123.7	101 106 112 118 124					
	125	125.3		131	130.7	131					
	132 140 150	132.3 140.3 150.3		138 146 156	137.7 145.7 155.7	138 146 156					

ISO Equivalent General Industrial Series (Static Applications)

Material	JIS	NBR-70-1
	Old JIS *	Class 1A
	NOK code	A305

*Old JIS: JIS B 2401-2005

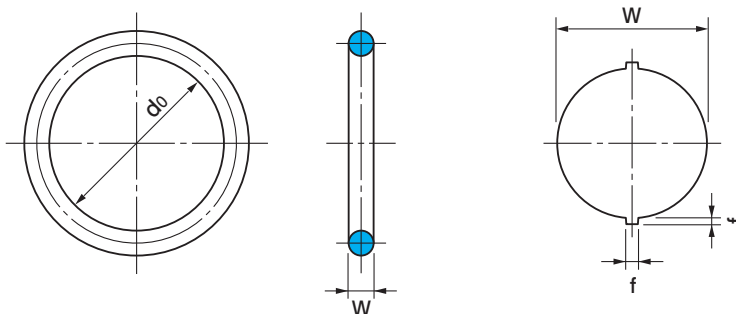

(Unit: mm)

NOK part number	(Old) ISO nominal number	O-ring dimensions						
		Thickness W	Inside diameter do	Burr dimension f				
CO 7200 A	A 0018 G	1.8	±0.08	1.80	0.1 or less			
CO 7201 A	A 0020 G			2.00				
CO 7202 A	A 0022 G			2.24 ±0.13				
CO 7203 A	A 0025 G			2.50				
CO 7204 A	A 0028 G			2.80				
CO 7205 A	A 0031 G			3.15				
CO 7206 A	A 0035 G			3.55 ±0.14				
CO 7207 A	A 0037 G			3.75				
CO 7208 A	A 0040 G			4.00				
CO 1012 A	A 0045 G			4.50				
CO 7209 A	A 0048 G			4.87				
CO 7210 A	A 0050 G			5.00				
CO 7211 A	A 0051 G			5.15 ±0.15				
CO 7212 A	A 0053 G			5.30				
CO 6868 A	A 0056 G			5.60				
CO 3026 A	A 0060 G			6.00				
CO 7213 A	A 0063 G			6.30				
CO 7038 A	A 0067 G			6.70 ±0.16				
CO 7214 A	A 0069 G	6.90						
CO 7215 A	A 0071 G	7.10						
CO 7216 A	A 0075 G	7.50						
CO 7217 A	A 0080 G	8.00						
CO 7218 A	A 0085 G	8.50						
CO 7219 A	A 0087 G	8.75 ±0.17						
CO 1061 A	A 0090 G	9.00						
CO 7221 A	A 0095 G	9.50						
CO 7222 A	A 0100 G	10.0						
CO 7223 A	A 0106 G	10.6 ±0.18						
CO 7224 A	A 0112 G	11.2						
CO 1109 A	A 0118 G	11.8						
CO 7225 A	A 0125 G	12.5 ±0.19						
CO 7226 A	A 0132 G	13.2						
CO 3441 A	A 0140 G	14.0						
CO 6822 A	A 0150 G	15.0 ±0.20						
CO 6861 A	A 0160 G	16.0						
CO 7227 A	A 0170 G	17.0 ±0.21						
CO 7228 A	B 0140 G	2.65	±0.09	14.0 ±0.19	0.12 or less			
CO 7229 A	B 0150 G			15.0 ±0.20				
CO 7230 A	B 0160 G			16.0				
CO 7231 A	B 0170 G			17.0 ±0.21				
CO 7232 A	B 0180 G			18.0				
CO 7233 A	B 0190 G			19.0 ±0.22				
CO 7234 A	B 0200 G			20.0				
CO 7235 A	B 0212 G			21.2 ±0.23				
CO 7236 A	B 0224 G			22.4 ±0.24				
CO 7237 A	B 0236 G			23.6				
CO 7238 A	B 0250 G			25.0 ±0.25				
CO 7239 A	B 0258 G			25.8 ±0.26				
CO 7240 A	B 0265 G			26.5				
CO 7241 A	B 0280 G			28.0 ±0.28				
CO 7242 A	B 0300 G			2.65		±0.09	30.0 ±0.29	0.12 or less
CO 7243 A	B 0315 G						31.5 ±0.31	
CO 7244 A	B 0325 G						32.5 ±0.32	
CO 7245 A	B 0335 G						33.5 ±0.32	
CO 7246 A	B 0345 G	34.5 ±0.33						
CO 7247 A	B 0355 G	35.5 ±0.34						
CO 7248 A	B 0365 G	36.5 ±0.35						
CO 7249 A	B 0375 G	37.5 ±0.36						
CO 7250 A	B 0387 G	38.7 ±0.37						
CO 7251 A	C 0180 G	3.55	±0.10		18.0 ±0.21		0.14 or less	
CO 7252 A	C 0190 G				19.0 ±0.22			
CO 7253 A	C 0200 G				20.0 ±0.22			
CO 7254 A	C 0212 G				21.2 ±0.23			
CO 7255 A	C 0224 G				22.4 ±0.24			
CO 7256 A	C 0236 G				23.6 ±0.25			
CO 7257 A	C 0250 G				25.0 ±0.26			
CO 7258 A	C 0258 G				25.8 ±0.26			
CO 7259 A	C 0265 G				26.5 ±0.26			
CO 7260 A	C 0280 G			28.0 ±0.28				
CO 7261 A	C 0300 G			30.0 ±0.29				
CO 7262 A	C 0315 G			31.5 ±0.31				
CO 7263 A	C 0325 G			32.5 ±0.32				
CO 7264 A	C 0335 G			33.5 ±0.32				
CO 7265 A	C 0345 G			34.5 ±0.33				
CO 7266 A	C 0355 G			35.5 ±0.34				
CO 7267 A	C 0365 G			36.5 ±0.35				
CO 7268 A	C 0375 G			37.5 ±0.36				
CO 7269 A	C 0387 G	38.7 ±0.37						
CO 7270 A	C 0400 G	40.0 ±0.38						
CO 7271 A	C 0412 G	41.2 ±0.39						
CO 7272 A	C 0425 G	42.5 ±0.40						
CO 7273 A	C 0437 G	43.7 ±0.41						
CO 7274 A	C 0450 G	45.0 ±0.42						
CO 7275 A	C 0462 G	46.2 ±0.43						
CO 7276 A	C 0475 G	47.5 ±0.44						
CO 7277 A	C 0487 G	48.7 ±0.45						
CO 7278 A	C 0500 G	50.0 ±0.46						
CO 7279 A	C 0515 G	51.5 ±0.47						
CO 7280 A	C 0530 G	53.0 ±0.48						
CO 7281 A	C 0545 G	54.5 ±0.50						
CO 7282 A	C 0560 G	56.0 ±0.51						
CO 7283 A	C 0580 G	58.0 ±0.52						
CO 7284 A	C 0600 G	60.0 ±0.54						
CO 7285 A	C 0615 G	61.5 ±0.55						
CO 7286 A	C 0630 G	63.0 ±0.56						
CO 7287 A	C 0650 G	65.0 ±0.58						
CO 7288 A	C 0670 G	67.0 ±0.59						
CO 7289 A	C 0690 G	69.0 ±0.61						
CO 7290 A	C 0710 G	71.0 ±0.63						
CO 7291 A	C 0730 G	73.0 ±0.64						

■ When ordering, please make sure to specify both the ① (Old) ISO nominal number and ② NOK part number.

Ex.) If you wish to purchase a part with an inside diameter of 31.5 and thickness of 2.65 made of material NBR-70-1:

- (Old) ISO nominal number: B 0315 G
- NOK part number: CO 7243 A

*Although the products meet the specifications of the JIS standard ISO Series, nominal numbers correspond with those for the Old JIS standard (JIS B 2401: 1996) ISO Series.

(Unit: mm)

NOK part number	(Old) ISO nominal number	O-ring dimensions				Burr dimension f	NOK part number	(Old) ISO nominal number	O-ring dimensions				Burr dimension f
		Thickness W		Inside diameter do					Thickness W		Inside diameter do		
CO 7292 A	C 0750 G	3.55	±0.10	75.0	±0.66	0.14 or less	CO 7341 A	D 0615 G	5.30	±0.13	61.5	±0.55	0.16 or less
CO 7293 A	C 0775 G			77.5	±0.67		CO 7342 A	D 0630 G			63.0	±0.56	
CO 7294 A	C 0800 G			80.0	±0.69		CO 7343 A	D 0650 G			65.0	±0.58	
CO 7295 A	C 0825 G			82.5	±0.71		CO 7344 A	D 0670 G			67.0	±0.59	
CO 7296 A	C 0850 G			85.0	±0.73		CO 7345 A	D 0690 G			69.0	±0.61	
CO 7297 A	C 0875 G			87.5	±0.75		CO 7346 A	D 0710 G			71.0	±0.63	
CO 7298 A	C 0900 G			90.0	±0.77		CO 7347 A	D 0730 G			73.0	±0.64	
CO 7299 A	C 0925 G			92.5	±0.79		CO 7348 A	D 0750 G			75.0	±0.66	
CO 7300 A	C 0950 G			95.0	±0.81		CO 7349 A	D 0775 G			77.5	±0.67	
CO 7301 A	C 0975 G			97.5	±0.83		CO 7350 A	D 0800 G			80.0	±0.69	
CO 7302 A	C 1000 G			100	±0.84		CO 7351 A	D 0825 G			82.5	±0.71	
CO 7303 A	C 1030 G			103	±0.87		CO 7352 A	D 0850 G			85.0	±0.73	
CO 7304 A	C 1060 G			106	±0.89		CO 7353 A	D 0875 G			87.5	±0.75	
CO 7305 A	C 1090 G			109	±0.91		CO 7354 A	D 0900 G			90.0	±0.77	
CO 7306 A	C 1120 G			112	±0.93		CO 7355 A	D 0925 G			92.5	±0.79	
CO 7307 A	C 1150 G	115	±0.95	CO 7356 A	D 0950 G	95.0	±0.81						
CO 7308 A	C 1180 G	118	±0.97	CO 7357 A	D 0975 G	97.5	±0.83						
CO 7309 A	C 1220 G	122	±1.00	CO 7358 A	D 1000 G	100	±0.84						
CO 7310 A	C 1250 G	125	±1.03	CO 7359 A	D 1030 G	103	±0.87						
CO 7311 A	C 1280 G	128	±1.05	CO 7360 A	D 1060 G	106	±0.89						
CO 7312 A	C 1320 G	132	±1.08	CO 7361 A	D 1090 G	109	±0.91						
CO 7313 A	C 1360 G	136	±1.10	CO 7362 A	D 1120 G	112	±0.93						
CO 7314 A	C 1400 G	140	±1.13	CO 7363 A	D 1150 G	115	±0.95						
CO 7315 A	C 1450 G	145	±1.17	CO 7364 A	D 1180 G	118	±0.97						
CO 7316 A	C 1500 G	150	±1.20	CO 7365 A	D 1220 G	122	±1.00						
CO 7317 A	C 1550 G	155	±1.24	CO 7366 A	D 1250 G	125	±1.03						
CO 7318 A	C 1600 G	160	±1.27	CO 7367 A	D 1280 G	128	±1.05						
CO 7319 A	C 1650 G	165	±1.31	CO 7368 A	D 1320 G	132	±1.08						
CO 7320 A	C 1700 G	170	±1.34	CO 7369 A	D 1360 G	136	±1.10						
CO 7321 A	C 1750 G	175	±1.38	CO 7370 A	D 1400 G	140	±1.13						
CO 7322 A	C 1800 G	180	±1.41	CO 7371 A	D 1450 G	145	±1.17						
CO 7323 A	C 1850 G	185	±1.44	CO 7372 A	D 1500 G	150	±1.20						
CO 7324 A	C 1900 G	190	±1.48	CO 7373 A	D 1550 G	155	±1.24						
CO 7325 A	C 1950 G	195	±1.51	CO 7374 A	D 1600 G	160	±1.27						
CO 7326 A	C 2000 G	200	±1.55	CO 7375 A	D 1650 G	165	±1.31						
CO 7327 A	D 0400 G	5.30	±0.13	40.0	±0.38	0.16 or less	CO 7376 A	D 1700 G	170	±1.34			
CO 7328 A	D 0412 G			41.2	±0.39		CO 7377 A	D 1750 G	175	±1.38			
CO 7329 A	D 0425 G			42.5	±0.40		CO 7378 A	D 1800 G	180	±1.41			
CO 7330 A	D 0437 G			43.7	±0.41		CO 7379 A	D 1850 G	185	±1.44			
CO 4643 A	D 0450 G			45.0	±0.42		CO 7380 A	D 1900 G	190	±1.48			
CO 7331 A	D 0462 G			46.2	±0.43		CO 7381 A	D 1950 G	195	±1.51			
CO 7332 A	D 0475 G			47.5	±0.44		CO 7382 A	D 2000 G	200	±1.55			
CO 7333 A	D 0487 G			48.7	±0.45		CO 7383 A	D 2060 G	206	±1.59			
CO 7334 A	D 0500 G			50.0	±0.46		CO 7384 A	D 2120 G	212	±1.63			
CO 7335 A	D 0515 G			51.5	±0.47		CO 7385 A	D 2180 G	218	±1.67			
CO 7336 A	D 0530 G			53.0	±0.48		CO 7386 A	D 2240 G	224	±1.71			
CO 7337 A	D 0545 G			54.5	±0.50		CO 7387 A	D 2300 G	230	±1.75			
CO 7338 A	D 0560 G			56.0	±0.51		CO 7388 A	D 2360 G	236	±1.79			
CO 7339 A	D 0580 G			58.0	±0.52		CO 7389 A	D 2430 G	243	±1.83			
CO 7340 A	D 0600 G			60.0	±0.54		CO 7390 A	D 2500 G	250	±1.88			

ISO Equivalent General Industrial Series (Static Applications)

Material	JIS	NBR-70-1
	Old JIS *	Class 1A
	NOK code	A305

*Old JIS: JIS B 2401-2005

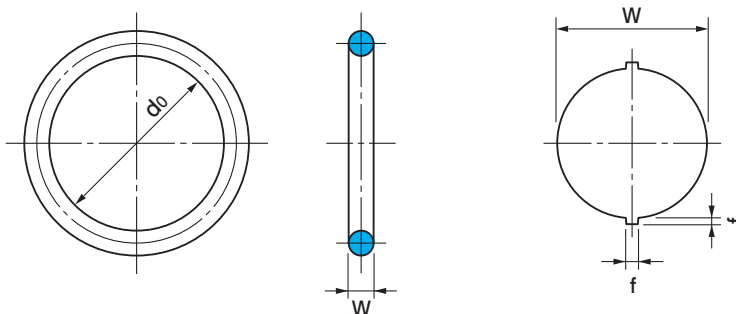

(Unit: mm)

NOK part number	(Old) ISO nominal number	O-ring dimensions							
		Thickness W		Inside diameter do	Burr dimension f				
CO 7391 A	D 2580 G	5.30	±0.13	258	±1.93	0.16 or less			
CO 7392 A	D 2650 G			265	±1.98				
CO 7393 A	D 2720 G			272	±2.02				
CO 7394 A	D 2800 G			280	±2.08				
CO 7395 A	D 2900 G			290	±2.14				
CO 7396 A	D 3000 G			300	±2.21				
CO 7397 A	D 3070 G			307	±2.25				
CO 7398 A	D 3150 G			315	±2.30				
CO 7399 A	D 3250 G			325	±2.37				
CO 7400 A	D 3350 G			335	±2.43				
CO 7401 A	D 3450 G	7.00	±0.15	345	±2.49	0.18 or less			
CO 7402 A	D 3550 G			355	±2.56				
CO 7403 A	D 3650 G			365	±2.62				
CO 7404 A	D 3750 G			375	±2.68				
CO 7405 A	D 3870 G			387	±2.76				
CO 7406 A	D 4000 G			400	±2.84				
CO 7407 A	E 1090 G			109	±0.91				
CO 7408 A	E 1120 G			112	±0.93				
CO 7409 A	E 1150 G			115	±0.95				
CO 7410 A	E 1180 G			118	±0.97				
CO 7411 A	E 1220 G	122	±1.00						
CO 7412 A	E 1250 G	7.00	±0.15	125	±1.03	0.18 or less			
CO 7413 A	E 1280 G			128	±1.05				
CO 7414 A	E 1320 G			132	±1.08				
CO 7415 A	E 1360 G			136	±1.10				
CO 7416 A	E 1400 G			140	±1.13				
CO 7417 A	E 1450 G			145	±1.17				
CO 7418 A	E 1500 G			150	±1.20				
CO 7419 A	E 1550 G			155	±1.24				
CO 7420 A	E 1600 G			160	±1.27				
CO 7421 A	E 1650 G			165	±1.31				
CO 7422 A	E 1700 G	7.00	±0.15	170	±1.34	0.18 or less			
CO 7423 A	E 1750 G			175	±1.38				
CO 7424 A	E 1800 G			180	±1.41				
CO 7425 A	E 1850 G			185	±1.44				
CO 7426 A	E 1900 G			190	±1.48				
CO 7427 A	E 1950 G			195	±1.51				
CO 7428 A	E 2000 G			200	±1.55				
CO 7429 A	E 2060 G			206	±1.59				
CO 7430 A	E 2120 G			212	±1.63				
CO 7431 A	E 2180 G			218	±1.67				
CO 7432 A	E 2240 G	7.00	±0.15	224	±1.71	0.18 or less			
CO 7433 A	E 2300 G			230	±1.75				
CO 7434 A	E 2360 G			236	±1.79				
CO 7435 A	E 2430 G			243	±1.83				
CO 7436 A	E 2500 G			250	±1.88				
CO 7437 A	E 2580 G			7.00	±0.15		258	±1.93	0.18 or less
CO 7438 A	E 2650 G						265	±1.98	
CO 7439 A	E 2720 G						272	±2.02	
CO 7440 A	E 2800 G						280	±2.08	
CO 7441 A	E 2900 G						7.00	±0.15	
CO 7442 A	E 3000 G	300	±2.21						
CO 7443 A	E 3070 G	307	±2.25						
CO 7444 A	E 3150 G	315	±2.30						
CO 7445 A	E 3250 G	325	±2.37						
CO 7446 A	E 3350 G	335	±2.43						
CO 7447 A	E 3450 G	345	±2.49						
CO 7448 A	E 3550 G	355	±2.56						
CO 7449 A	E 3650 G	365	±2.63						
CO 7450 A	E 3750 G	375	±2.68						
CO 7451 A	E 3870 G	7.00	±0.15	387	±2.76	0.18 or less			
CO 7452 A	E 4000 G			400	±2.84				
CO 7453 A	E 4120 G			412	±2.91				
CO 7454 A	E 4250 G			425	±2.99				
CO 7455 A	E 4370 G			437	±3.07				
CO 7456 A	E 4500 G			450	±3.15				
CO 6711 A	E 4620 G			462	±3.22				
CO 7457 A	E 4750 G			475	±3.30				
CO 7458 A	E 4870 G			487	±3.37				
CO 7459 A	E 5000 G			500	±3.45				
CO 7460 A	E 5150 G	7.00	±0.15	515	±3.54	0.18 or less			
CO 7461 A	E 5300 G			530	±3.63				
CO 7462 A	E 5450 G			545	±3.72				
CO 7463 A	E 5600 G			560	±3.81				
CO 7464 A	E 5800 G			580	±3.93				
CO 7465 A	E 6000 G			600	±4.05				
CO 7466 A	E 6150 G			615	±4.13				
CO 7467 A	E 6300 G			630	±4.22				
CO 7468 A	E 6500 G			650	±4.34				
CO 7469 A	E 6700 G			670	±4.46				

■ When ordering, please make sure to specify both the ① (Old) ISO nominal number and ② NOK part number.
 Ex.) If you wish to purchase a part with an inside diameter of 31.5 and thickness of 2.65 made of material NBR-70-1:
 • (Old) ISO nominal number: B 0315 G
 • NOK part number: CO 7243 A

*Although the products meet the specifications of the JIS standard ISO Series, nominal numbers correspond with those for the Old JIS standard (JIS B 2401: 1996) ISO Series.

NOK WEX Series (O-Ring series for water applications: Static/Dynamic Applications)

Material	Material code	7W	5W	FW	FBW
	NOK code	E700	E575	FP29	FP739
	Hue	Black	Violet	Black	Brown

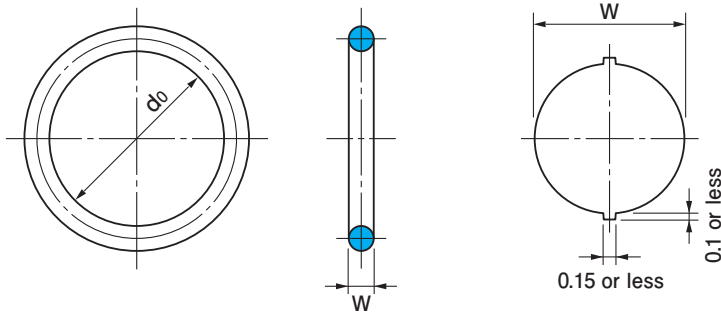

(Unit: mm)

Type Dimension code	NOK part number				NOK nominal number ← Take the material code to the left and substitute it for the "□" □ P 3 □ P 4 □ P 5 □ P 6 □ P 7 □ P 8 □ P 9 □ P 10 □ P 10 A □ P 11 □ P 12 □ P 12.5 □ P 14 □ P 15 □ P 16 □ P 18 □ P 20	O-ring dimensions						
	7W	5W	FW	FBW		Thickness W	Inside diameter do	Tolerance of inside diameter 'do'				
	E700	E575	FP29	FP739				E700 E575	FP29 FP739			
CO 0000 CO 0001 CO 0002 CO 0003 CO 0004	Z1 N1 G1 R3 Y3	O2 N2 U2 H3 G5	P3 X2 G5 S3 N4	CO 60000 H0 CO 60001 F0 CO 60002 E0 CO 60003 G0 CO 60004 F0	1.9±0.07	2.8 3.8 4.8 5.8 6.8	±0.36	±0.24				
CO 0005 CO 0006 CO 0007	Z4 V2 O4	Z2 H3 G5	G7 N3 R3	CO 60005 H0 CO 60006 E0 CO 60007 J0								
CO 0008 CO 0009 CO 0011 CO 0012	H4 Y1 Y1 G3	Z5 H3 Z4 H2	H6 V2 V2 H4	CO 60008 F0 CO 60009 D0 CO 60011 E0 CO 60012 G0					2.4±0.07	9.8 10.8 11.8 12.3 13.8 14.8 15.8 17.8 19.8	±0.45	±0.30
CO 0013 CO 0014 CO 0015 CO 0016 CO 0017	Z3 H4 T2 N2 X2	S2 H3 G3 P3 G4	N3 Z4 V1 Z3 O2	CO 60013 G0 CO 60014 F0 CO 60015 I0 CO 60016 M0 CO 60017 I0								

■ Note:

- The WEX Series is a series that has been designed for applications that use water, such as cogeneration systems, and they are made in compliance with the JIS B 2401-1 P Series using NOK's 4 recommended materials.
- The materials and their characteristics are shown below.

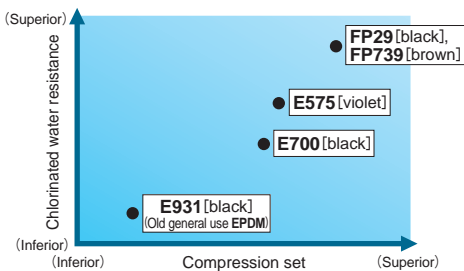

- Although they are designed with dimensions that conform with the JIS B 2401-1 P Series, since they are special rubber materials, the tolerances are set to NOK's standard tolerances.
- Please refer to page 23 for details on groove dimensions.
- This series is produced using processes that aim to meet the requirements of the Food Sanitation Act.
- Except for in special cases, NOK recommends FP29 for high-temperature, long-term usage.

■ When ordering, please make sure to specify both the ① NOK nominal number and ② NOK part number.

- Ex.1) If you wish to purchase a part with an inside diameter of 7.8 and thickness of 1.9 made of NOK code FP29:
 • NOK part number: **CO 0005 G7**
 Type/dimension code | Material code
- Ex.2) If you wish to purchase a part with an inside diameter of 7.8 and thickness of 1.9 made of NOK code E700:
 • NOK part number: **CO 0005 Z4**
 Type/dimension code | Material code

■ Estimated time to reach 80% compression set

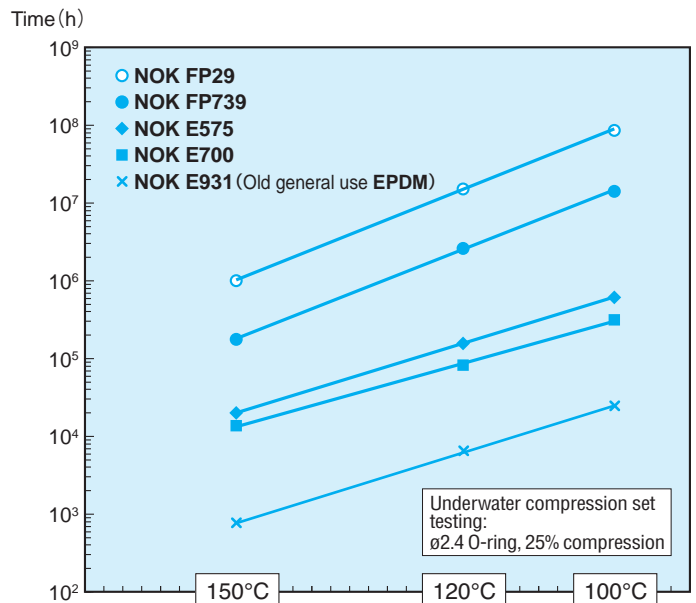

WEX Series

NOK Iron Rubber P, G Series (Static/Dynamic Applications)

Material (NOK code) U801

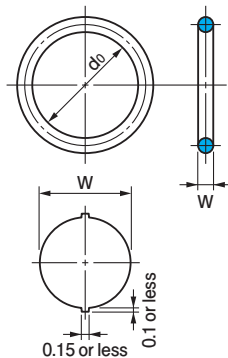

O-Ring Dimensions

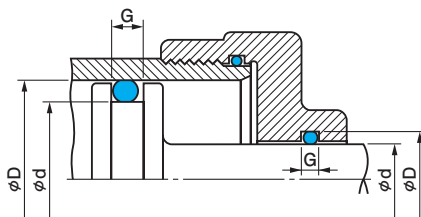

For Dynamic Applications

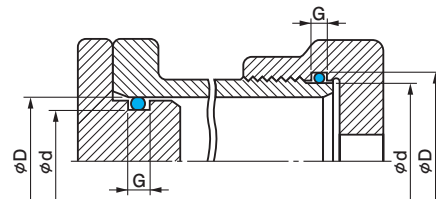

For Cylindrical Surface Static Applications

P Series

(Unit: mm)

NOK part number		NOK nominal number	O-ring dimensions		Groove dimensions																			
Type Dimension code	Material code		Thickness W	Tolerance of inside diameter 'd ₀ '		Dimension d		Dimension D		Dimension G (tolerance $\begin{smallmatrix} +0.25 \\ 0 \end{smallmatrix}$)			Dimension H	Dimension R										
	U801			d ₀	Tolerance	d	Tolerance	D	Tolerance	No backup rings	Backup ring on one side	Backup rings on both sides	H±0.05	Max. value										
FR 0318 FR 0383 FR 0457 FR 0458 FR 0278	W	P 3	1.9±0.08	2.8	±0.16	3	0	6	+0.05	2.5	3.9	5.4	1.4	0.4										
P 4		3.8		4		7																		
P 5		4.8		5		8																		
P 6		5.8		6		9																		
P 7		6.8		7		10																		
P 8		7.8		8		11																		
P 9		8.8		9		12																		
P 10		9.8		10		13																		
FR 0246 FR 0460 FR 0337 FR 0461 FR 0462		W		P 10A		2.4±0.09		9.8							±0.22	10	0	14	+0.06	3.2	4.4	6.0	1.8	0.4
P 11				10.8				11								15								
P 11.2	11.0		11.2	15.2																				
P 12	11.8		12	16																				
P 12.5	12.3		12.5	16.5																				
P 14	13.8		14	18																				
P 15	14.8		15	19																				
P 16	15.8		16	20																				
P 18	17.8		18	22																				
P 20	19.8		20	24																				
FR 0464 FR 0386	P 21 P 22	20.8 21.8	21 22	25 26																				
FR 0384 FR 0310 FR 0092 FR 0250 FR 0465	W	P 22A	3.5±0.1	21.7	±0.28	22	0	28	+0.08	4.7	6.0	7.8	2.7	0.7										
P 22.4		22.1		22.4		28.4																		
P 24		23.7		24		30																		
P 25		24.7		25		31																		
P 25.5		25.2		25.5		31.5																		
P 26		25.7		26		32																		
P 28		27.7		28		34																		
P 29		28.7		29		35																		
P 29.5		29.2		29.5		35.5																		
P 30		29.7		30		36																		
FR 0467 FR 0468 FR 0311 FR 0361 FR 0133	W	P 31	3.5±0.1	30.7	±0.36	31	0	37	+0.08	4.7	6.0	7.8	2.7	0.7										
P 31.5		31.2		31.5		37.5																		
P 32		31.7		32		38																		
P 34		33.7		34		40																		
P 35		34.7		35		41																		
P 35.5		35.2		35.5		41.5																		
P 36		35.7		36		42																		
P 38		37.7		38		44																		
P 39		38.7		39		45																		
P 40		39.7		40		46																		
FR 0471 FR 0158 FR 0385 FR 0377 FR 0472	W	P 41	3.5±0.1	40.7	±0.45	41	0	47	+0.08	4.7	6.0	7.8	2.7	0.7										
P 42		41.7		42		48																		
P 44		43.7		44		50																		
P 45		44.7		45		51																		
P 46		45.7		46		52																		
P 48		47.7		48		54																		
FR 0379 FR 0473 FR 0474	W	P 49	3.5±0.1	48.7	±0.52	49	0	55	+0.08	4.7	6.0	7.8	2.7	0.7										
P 50		49.7		50		56																		

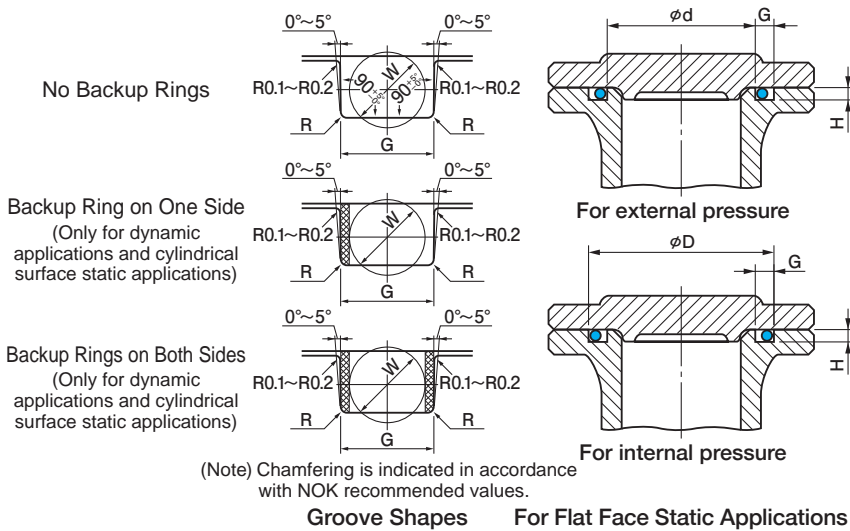

■ When ordering, please make sure to specify the NOK part number.
 Ex.) If you wish to purchase a part with an inside diameter of 25.7 and thickness of 3.5 made of material U801:
 • NOK part number: **FR 0364 W**
 Type/dimension code: **FR 0364** Material code: **W**

G Series

(Unit: mm)

NOK part number		NOK nominal number	O-ring dimensions		Groove dimensions									
Type	Material code		Thickness W	Tolerance of inside diameter 'd ₀ '		Dimension d		Dimension D		Dimension G (tolerance $+0.25_0$)			Dimension H	Dimension R
Dimension code	U801			d ₀	Tolerance	d	Tolerance	D	Tolerance	No backup rings	Backup ring on one side	Backup rings on both sides	H±0.05	Max. value
FR 0285	W	G 25	24.4	±0.30	25	0 -0.1	30	+0.1 0	4.1	5.6	7.3	2.4	0.7	
FR 0286		G 30	29.4	±0.34	30		35							
FR 0475		G 35	34.4	±0.39	35		40							
FR 0149		G 40	39.4	±0.44	40		45							
FR 0476		G 45	44.4	±0.49	45		50							
FR 0477	G 50	49.4	±0.54	50	55									

Iron Rubber O-rings are products designed to be compatible with JIS B 2401-1 (P, G series).

● Iron Rubber characteristics

1. High tensile strength
2. High tearing strength
3. High elasticity
4. Load bearing performance
5. Wear resistance

These 5 characteristics represent the most exceptional qualities among the numerous superior properties of this material. This pioneering material can be applied in fields where conventional rubber, plastic, metal, and other industrial materials could not be used, thereby opening up possibilities for new applications.

● Other characteristics

Oil, chemical, and water resistance:
 Having superior oil resistance equivalent to that of nitrile rubber.
 Also appropriate for use with other substances, such as fuels, ethers, edible oils, and salts. Vastly superior in terms of water resistance when compared to general polyurethane.

● Ozone resistance

Highly superior resistance that is equivalent to fluororubber and silicone rubber.

● Tensile strength - Young's modulus/hardness

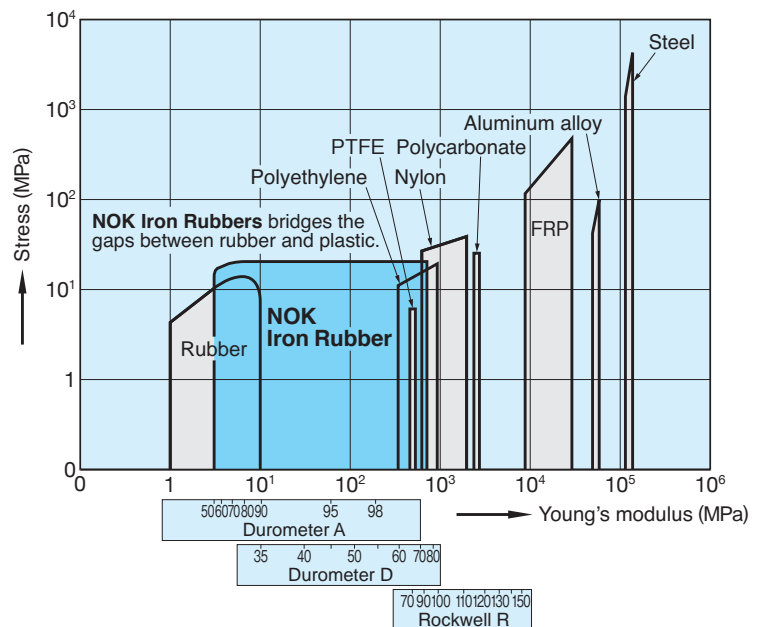

**Iron Rubber" is a registered trademark of NOK (Trademark Registration No.: 2609032).

JIS B 2401-4 Equivalent Backup Rings

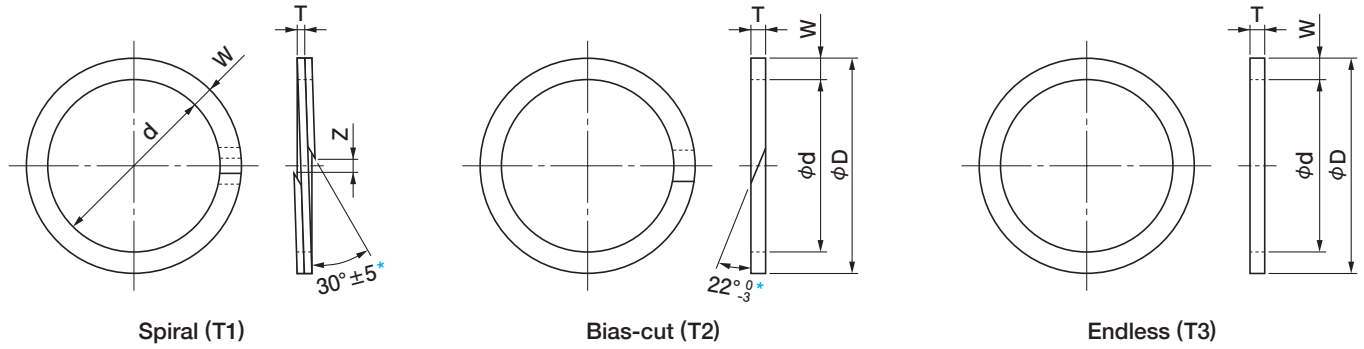

*The cutting angle for the nominal numbers on pages 3 through 10 is $40^{\circ} \pm 0.5$

For P Series Use

(Unit: mm)

NOK part number			Backup ring nominal number	Spiral				Bias-cut and endless				Applicable O-ring JIS B 2401-1 dimension number		
T1 (spiral)	T2 (bias-cut)	T3 (endless)		Inside diameter ϕd	Width W	Thickness T	Clearance Z	Inside diameter ϕd	Outside diameter ϕD	Thickness T				
GN 0090 A1	GN 0367 A3	GN 0711 A0	P 3	3	$1.5^{+0.03}_{-0.05}$	0.7 ± 0.05	1.2 ± 0.4	3	6	0	1.25 ± 0.1	P 3		
GN 0093 A1	GN 0370 A2	GN 0714 A0	P 4	4				4	7			P 4		
GN 0095 A1	GN 0372 A3	GN 0716 A0	P 5	5				5	8			P 5		
GN 0097 A1	GN 0375 A2	GN 0719 A0	P 6	6				6	9			P 6		
GN 0099 A1	GN 0378 A2	GN 0722 A0	P 7	7				7	10			P 7		
GN 0101 A1	GN 0380 A5	GN 0724 A0	P 8	8				8	11			P 8		
GN 0102 A1	GN 0382 A4	GN 0727 A0	P 9	9				9	12			P 9		
GN 0105 A1	GN 0386 A2	GN 0731 A0	P 10	10	10	13	P 10							
GN 0106 A0	GN 0387 A0	GN 0732 A0	P 10A	10	$2.0^{+0.03}_{-0.05}$	0.7 ± 0.05	1.4 ± 0.8	10	14	0	1.25 ± 0.1	P 10A		
GN 0107 A0	GN 0389 A0	GN 0734 A0	P 11	11				11	15			P 11		
GN 0109 A0	GN 0390 A0	GN 0735 A0	P 11.2	11.2				11.2	15.2			P 11.2		
GN 0110 A0	GN 0393 A0	GN 0739 A0	P 12	12				12	16			P 12		
GN 0111 A0	GN 0395 A0	GN 0740 A0	P 12.5	12.5				12.5	16.5			P 12.5		
GN 0113 A0	GN 0398 A0	GN 0744 A0	P 14	14				14	18			P 14		
GN 0115 A0	GN 0401 A0	GN 0748 A0	P 15	15	15	19	P 15							
GN 0117 A0	GN 0402 A0	GN 0750 A0	P 16	16	16	20	P 16							
GN 0119 A0	GN 0408 A0	GN 0756 A0	P 18	18	18	22	P 18							
GN 0122 A0	GN 0413 A0	GN 0761 A0	P 20	20	20	24	P 20							
GN 0124 A0	GN 0414 A0	GN 0763 A0	P 21	21	21	25	25	25	25	25	P 21			
GN 0125 A0	GN 0418 A0	GN 0768 A0	P 22	22								22	26	26
GN 0126 A0	GN 0419 A0	GN 0769 A0	P 22A	22	$3.0^{+0.03}_{-0.05}$	0.7 ± 0.05	2.5 ± 1.5	22	28	0	1.25 ± 0.1	P 22A		
GN 0128 A0	GN 0420 A0	GN 0770 A0	P 22.4	22.4				22.4	28.4			P 22.4		
GN 0130 A0	GN 0425 A0	GN 0775 A0	P 24	24				24	30			P 24		
GN 0132 A0	GN 0430 A0	GN 0780 A0	P 25	25				25	31			P 25		
GN 0134 A0	GN 0431 A0	GN 0782 A0	P 25.5	25.5				25.5	31.5			P 25.5		
GN 0135 A0	GN 0435 A0	GN 0786 A0	P 26	26				26	32			P 26		
GN 0137 A0	GN 0439 A0	GN 0790 A0	P 28	28	28	34	P 28							
GN 0139 A0	GN 0441 A0	GN 0793 A0	P 29	29	29	35	P 29							
GN 0140 A0	GN 0444 A0	GN 0796 A0	P 29.5	29.5	29.5	35.5	P 29.5							
GN 0142 A0	GN 0446 A0	GN 0798 A0	P 30	30	30	36	P 30							
GN 0144 A0	GN 0451 A0	GN 0803 A0	P 31	31	$3.0^{+0.03}_{-0.05}$	0.7 ± 0.05	2.5 ± 1.5	31	37	0	1.25 ± 0.1	P 31		
GN 0145 A0	GN 0452 A0	GN 0804 A0	P 31.5	31.5				31.5	37.5			P 31.5		
GN 0147 A0	GN 0453 A0	GN 0806 A0	P 32	32				32	38			P 32		
GN 0149 A0	GN 0460 A0	GN 0813 A0	P 34	34				34	40			P 34		
GN 0152 A0	GN 0462 A0	GN 0815 A0	P 35	35				35	41			P 35		
GN 0153 A0	GN 0465 A0	GN 0819 A0	P 35.5	35.5				35.5	41.5			P 35.5		
GN 0154 A0	GN 0467 A0	GN 0822 A0	P 36	36	36	42	P 36							
GN 0156 A0	GN 0470 A0	GN 0825 A0	P 38	38	38	44	P 38							
GN 0159 A0	GN 0475 A0	GN 0829 A0	P 39	39	39	45	P 39							
GN 0160 A0	GN 0477 A0	GN 0831 A0	P 40	40	40	46	P 40							
GN 0161 A0	GN 0479 A0	GN 0834 A0	P 41	41	41	47	47	47	47	47	P 41			
GN 0164 A0	GN 0483 A0	GN 0839 A0	P 42	42								42	48	P 42
GN 0165 A0	GN 0485 A0	GN 0841 A0	P 44	44								44	50	P 44
GN 0169 A0	GN 0489 A0	GN 0844 A0	P 45	45								45	51	P 45
GN 0170 A0	GN 0492 A0	GN 0848 A0	P 46	46								46	52	P 46
GN 0173 A0	GN 0495 A0	GN 0851 A0	P 48	48								48	54	P 48
GN 0175 A0	GN 0499 A0	GN 0856 A0	P 49	49	49	55	P 49							
GN 0177 A0	GN 0502 A0	GN 0859 A0	P 50	50	50	56	P 50							

Note: Since there are cases where usage may not be appropriate depending on the usage conditions (for extremely high pressure or dynamic applications), please make sure to consult with NOK.

■ When ordering, please make sure to specify the NOK part number.
 Ex.1) If you wish to purchase a bias-cut backup ring to use with O-ring P85:
 • NOK part number: GN 0563 A0
 Ex.2) If you wish to purchase an endless backup ring to use with O-ring P85:
 • NOK part number: GN 0931 A0

*1: For bias-cut and endless backup rings, the difference between the max. value and min. value for W for the same backup ring shall be 0.05 mm or less.
 *2: Dimension Z indicates clearance when the backup ring is installed to a shaft for the O-ring nominal inside diameter.
 *3: Bias-cut backup rings are made by adding a cut to a portion of an endless backup ring.
 *4: "Rareflon" is a registered trademark of NOK for PTFE (Registered Trademark No.: 0792983).
 *5: For details on the properties of Rareflon (10FF), please refer to Chapter C in the Standard Products Technical Notes (Cat. No.003).

Types of Backup Rings

Type	Material	Shape
T1	Rareflon (10FF)	Spiral
T2	Rareflon (10FF)	Bias-cut
T3	Rareflon (10FF)	Endless

For P Series Use

(Unit: mm)

NOK part number			Backup ring nominal number	Spiral				Bias-cut and endless			Applicable O-ring JIS B 2401-1 dimension number	
T1 (spiral)	T2 (bias-cut)	T3 (endless)		Inside diameter d	Width W	Thickness T	Clearance Z	Inside diameter d	Outside diameter D	Thickness T		
GN 0174 A0	GN 0496 A0	GN 0852 A0	P 48A	48				48	58		P 48A	
GN 0178 A0	GN 0503 A0	GN 0860 A0	P 50A	50				50	60		P 50A	
GN 0180 A0	GN 0507 A0	GN 0866 A0	P 52	52				52	62		P 52	
GN 0181 A0	GN 0509 A0	GN 0868 A0	P 53	53				53	63		P 53	
GN 0185 A0	GN 0515 A0	GN 0874 A0	P 55	55				55	65		P 55	
GN 0186 A0	GN 0516 A0	GN 0876 A0	P 56	56				56	66		P 56	
GN 0189 A0	GN 0521 A0	GN 0882 A0	P 58	58				58	68		P 58	
GN 0191 A0	GN 0524 A0	GN 0885 A0	P 60	60				60	70		P 60	
GN 0194 A0	GN 0529 A0	GN 0890 A0	P 62	62				62	72		P 62	
GN 0195 A0	GN 0531 A0	GN 0892 A0	P 63	63				63	73		P 63	
GN 0199 A0	GN 0536 A0	GN 0898 A0	P 65	65				65	75		P 65	
GN 0202 A0	GN 0540 A0	GN 0903 A0	P 67	67				67	77		P 67	
GN 0206 A0	GN 0545 A0	GN 0909 A0	P 70	70				70	80		P 70	
GN 0207 A0	GN 0548 A0	GN 0913 A0	P 71	71				71	81		P 71	
GN 0211 A0	GN 0553 A0	GN 0919 A0	P 75	75				75	85		P 75	
GN 0216 A0	GN 0559 A0	GN 0926 A0	P 80	80	5.0 ^{+0.03} _{-0.05}	0.9±0.06	4.5 ±1.5	80	90	0	1.9 ±0.13	P 80
GN 0220 A0	GN 0563 A0	GN 0931 A0	P 85	85				85	95	-0.25		P 85
GN 0226 A0	GN 0569 A0	GN 0938 A0	P 90	90				90	100			P 90
GN 0230 A0	GN 0573 A0	GN 0944 A0	P 95	95				95	105			P 95
GN 0236 A0	GN 0579 A0	GN 0951 A0	P 100	100				100	110			P 100
GN 0239 A0	GN 0581 A0	GN 0954 A0	P 102	102				102	112			P 102
GN 0243 A0	GN 0585 A0	GN 0958 A0	P 105	105				105	115			P 105
GN 0246 A0	GN 0590 A0	GN 0965 A0	P 110	110				110	120			P 110
GN 0249 A0	GN 0593 A0	GN 0969 A0	P 112	112				112	122			P 112
GN 0254 A0	GN 0596 A0	GN 0973 A0	P 115	115				115	125			P 115
GN 0258 A0	GN 0602 A0	GN 0981 A0	P 120	120				120	130			P 120
GN 0262 A0	GN 0605 A0	GN 0985 A0	P 125	125				125	135			P 125
GN 0265 A0	GN 0609 A0	GN 0990 A0	P 130	130				130	140			P 130
GN 0267 A0	GN 0611 A0	GN 0993 A0	P 132	132				132	142			P 132
GN 0270 A0	GN 0614 A0	GN 0997 A0	P 135	135				135	145			P 135
GN 0274 A0	GN 0617 A0	GN 1001 A0	P 140	140				140	150			P 140
GN 0277 A0	GN 0621 A0	GN 1006 A0	P 145	145				145	155			P 145
GN 0280 A0	GN 0623 A0	GN 1009 A2	P 150	150				150	160			P 150
GN 0281 A0	GN 0624 A0	GN 1010 A0	P 150A	150				150	165			P 150A
GN 0284 A0	GN 0628 A0	GN 1015 A0	P 155	155				155	170			P 155
GN 0287 A0	GN 0631 A0	GN 1019 A0	P 160	160				160	175			P 160
GN 0289 A0	GN 0633 A0	GN 1022 A0	P 165	165				165	180			P 165
GN 0292 A0	GN 0636 A0	GN 1026 A0	P 170	170				170	185			P 170
GN 0295 A0	GN 0639 A0	GN 1030 A0	P 175	175				175	190			P 175
GN 0298 A0	GN 0642 A0	GN 1034 A0	P 180	180				180	195			P 180
GN 0301 A0	GN 0645 A0	GN 1038 A0	P 185	185	7.5 ^{+0.03} _{-0.05}	1.4 ±0.08	6.0 ±2.0	185	200	0	2.75 ±0.15	P 185
GN 0303 A0	GN 0647 A0	GN 1041 A0	P 190	190				190	205	-0.30		P 190
GN 0306 A0	GN 0650 A0	GN 1045 A0	P 195	195				195	210			P 195
GN 0309 A0	GN 0653 A0	GN 1049 A0	P 200	200				200	215			P 200
GN 0311 A0	GN 0655 A0	GN 1052 A0	P 205	205				205	220			P 205
GN 0312 A0	GN 0656 A0	GN 1054 A0	P 209	209				209	224			P 209
GN 0314 A0	GN 0658 A0	GN 1056 A0	P 210	210				210	225			P 210
GN 0315 A0	GN 0659 A0	GN 1059 A0	P 215	215				215	230			P 215

JIS B 2401-4 Equivalent Backup Rings

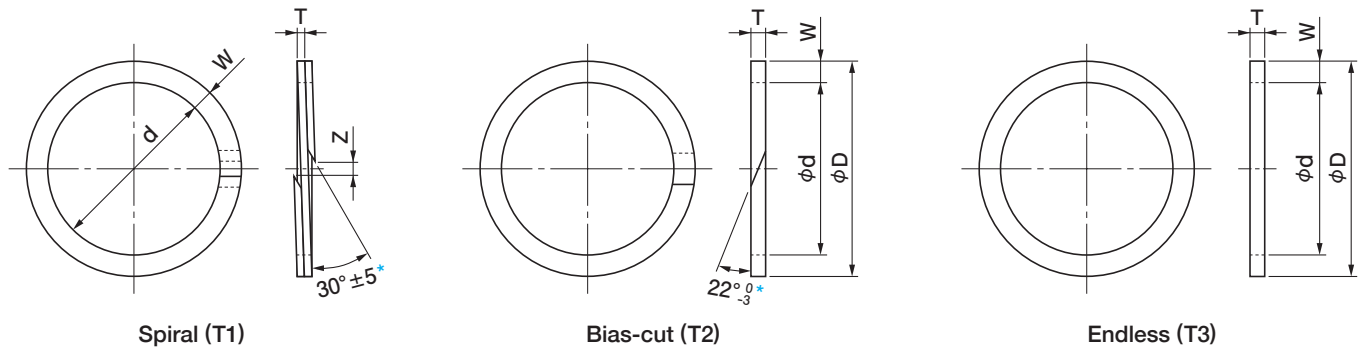

*The cutting angle for the nominal numbers on pages 3 through 10 is $40^{\circ} \frac{0}{5}$

For P Series Use

(Unit: mm)

NOK part number			Backup ring nominal number	Spiral				Bias-cut and endless			Applicable O-ring JIS B 2401-1 dimension number	
T1 (spiral)	T2 (bias-cut)	T3 (endless)		Inside diameter d	Width W	Thickness T	Clearance Z	Inside diameter d	Outside diameter D	Thickness T		
GN 0318 A0	GN 0662 A0	GN 1062 A0	P 220	220				220	235		P 220	
GN 0319 A0	GN 0663 A0	GN 1064 A0	P 225	225				225	240		P 225	
GN 0322 A0	GN 0666 A0	GN 1068 A0	P 230	230				230	245		P 230	
GN 0323 A0	GN 0667 A0	GN 1070 A0	P 235	235				235	250		P 235	
GN 0325 A0	GN 0669 A0	GN 1072 A0	P 240	240				240	255		P 240	
GN 0327 A0	GN 0671 A0	GN 1075 A0	P 245	245				245	260		P 245	
GN 0329 A0	GN 0673 A0	GN 1077 A0	P 250	250				250	265		P 250	
GN 0331 A0	GN 0675 A0	GN 1080 A0	P 255	255				255	270		P 255	
GN 0333 A0	GN 0677 A0	GN 1082 A0	P 260	260				260	275		P 260	
GN 0334 A0	GN 0678 A0	GN 1084 A0	P 265	265				265	280		P 265	
GN 0337 A0	GN 0681 A0	GN 1088 A0	P 270	270				270	285		P 270	
GN 0338 A0	GN 0682 A0	GN 1090 A0	P 275	275				275	290		P 275	
GN 0341 A0	GN 0684 A0	GN 1092 A0	P 280	280				280	295		P 280	
GN 0342 A0	GN 0686 A0	GN 1095 A0	P 285	285	$7.5^{+0.03}_{-0.05}$	1.4 ± 0.08	6.0 ± 2.0	$285^{+0.30}_0$	300	$0_{-0.30}$	2.75 ± 0.15	P 285
GN 0344 A0	GN 0688 A0	GN 1097 A0	P 290	290				290	305		P 290	
GN 0346 A0	GN 0690 A0	GN 1100 A0	P 295	295				295	310		P 295	
GN 0348 A0	GN 0692 A0	GN 1102 A0	P 300	300				300	315		P 300	
GN 0350 A0	GN 0694 A0	GN 1106 A0	P 315	315				315	330		P 315	
GN 0352 A0	GN 0696 A0	GN 1108 A0	P 320	320				320	335		P 320	
GN 0354 A0	GN 0698 A0	GN 1112 A0	P 335	335				335	350		P 335	
GN 0355 A0	GN 0699 A0	GN 1113 A0	P 340	340				340	355		P 340	
GN 0357 A0	GN 0701 A0	GN 1117 A0	P 355	355				355	370		P 355	
GN 0359 A0	GN 0703 A0	GN 1119 A0	P 360	360				360	375		P 360	
GN 0361 A0	GN 0705 A0	GN 1123 A0	P 375	375				375	390		P 375	
GN 0363 A0	GN 0707 A0	GN 1126 A0	P 385	385				385	400		P 385	
GN 0365 A0	GN 0709 A0	GN 1129 A0	P 400	400				400	415		P 400	

Note: Since there are cases where usage may not be appropriate depending on the usage conditions (for extremely high pressure or dynamic applications), please make sure to consult with NOK.

■ When ordering, please make sure to specify the NOK part number.
 Ex.1) If you wish to purchase a bias-cut backup ring to use with O-ring P240:
 • NOK part number: GN 0669 A0
 Ex.2) If you wish to purchase an endless backup ring to use with O-ring P240:
 • NOK part number: GN 1072 A0

*1: For bias-cut and endless backup rings, the difference between the max. value and min. value for W for the same backup ring shall be 0.05 mm or less.
 *2: Dimension Z indicates clearance when the backup ring is installed to a shaft for the O-ring nominal inside diameter.
 *3: Bias-cut backup rings are made by adding a cut to a portion of an endless backup ring.
 *4: "Rareflon" is a registered trademark of NOK for PTFE (Registered Trademark No.: 0792983).
 *5: For details on the properties of Rareflon (10FF), please refer to Chapter C in the Standard Products Technical Notes (Cat. No.003).

Types of Backup Rings

Type	Material	Shape
T1	Rareflon (10FF)	Spiral
T2	Rareflon (10FF)	Bias-cut
T3	Rareflon (10FF)	Endless

For G Series Use

(Unit: mm)

NOK part number			Backup ring nominal number	Spiral				Bias-cut and endless			Applicable O-ring JIS B 2401-1 dimension number	
T1 (spiral)	T2 (bias-cut)	T3 (endless)		Inside diameter d	Width W	Thickness T	Clearance Z	Inside diameter d	Outside diameter D	Thickness T		
GN 0131 A0	GN 0429 A0	GN 0779 A0	G 25	25				25		30		G 25
GN 0141 A0	GN 0445 A0	GN 0797 A0	G 30	30				30		35		G 30
GN 0151 A0	GN 0461 A0	GN 0814 A0	G 35	35				35		40		G 35
GN 1131 A0	GN 0476 A0	GN 0830 A0	G 40	40				40	+0.20	45	0	G 40
GN 0168 A0	GN 0488 A0	GN 0843 A0	G 45	45				45	0	50	-0.20	G 45
GN 0176 A0	GN 0501 A0	GN 0858 A0	G 50	50				50		55		G 50
GN 0184 A0	GN 0514 A0	GN 0873 A0	G 55	55				55		60		G 55
GN 0190 A0	GN 0523 A0	GN 0884 A0	G 60	60				60		65		G 60
GN 0198 A0	GN 0535 A0	GN 0897 A0	G 65	65				65		70		G 65
GN 0205 A0	GN 0543 A0	GN 0907 A0	G 70	70				70		75		G 70
GN 0210 A0	GN 0552 A0	GN 0918 A0	G 75	75				75		80		G 75
GN 0215 A0	GN 0558 A0	GN 0925 A0	G 80	80				80		85		G 80
GN 0219 A0	GN 0562 A0	GN 0930 A0	G 85	85	2.5 ^{+0.03} _{-0.05}	0.7 ^{±0.05}	4.5 ^{±1.5}	85		90	1.25 ^{±0.10}	G 85
GN 0225 A0	GN 0568 A0	GN 0937 A0	G 90	90				90		95		G 90
GN 0229 A0	GN 0572 A0	GN 0943 A0	G 95	95				95		100		G 95
GN 0235 A0	GN 0578 A0	GN 0950 A0	G 100	100				100	+0.25	105	-0.25	G 100
GN 0242 A0	GN 0584 A0	GN 0957 A0	G 105	105				105	0	110		G 105
GN 0245 A0	GN 0589 A0	GN 0964 A0	G 110	110				110		115		G 110
GN 0253 A0	GN 0595 A0	GN 0972 A0	G 115	115				115		120		G 115
GN 0257 A0	GN 0601 A0	GN 0980 A0	G 120	120				120		125		G 120
GN 0261 A0	GN 0604 A0	GN 0984 A0	G 125	125				125		130		G 125
GN 0264 A0	GN 0608 A0	GN 0989 A0	G 130	130				130		135		G 130
GN 0269 A0	GN 0613 A0	GN 0996 A0	G 135	135				135		140		G 135
GN 0273 A0	GN 0616 A0	GN 1000 A0	G 140	140				140		145		G 140
GN 0276 A0	GN 0620 A0	GN 1005 A0	G 145	145				145		150		G 145
GN 0280 A2	GN 0623 A2	GN 1009 A3	G 150	150				150		160		G 150
GN 0283 A0	GN 0627 A0	GN 1014 A0	G 155	155				155		165		G 155
GN 0286 A0	GN 0630 A0	GN 1018 A0	G 160	160				160		170		G 160
GN 0288 A0	GN 0632 A0	GN 1021 A0	G 165	165				165		175		G 165
GN 0291 A0	GN 0635 A0	GN 1025 A0	G 170	170				170		180		G 170
GN 0294 A0	GN 0638 A0	GN 1029 A0	G 175	175				175		185		G 175
GN 0297 A0	GN 0641 A0	GN 1033 A0	G 180	180				180		190		G 180
GN 0300 A0	GN 0644 A0	GN 1037 A0	G 185	185				185		195		G 185
GN 0302 A0	GN 0646 A0	GN 1040 A0	G 190	190				190		200		G 190
GN 0305 A0	GN 0649 A0	GN 1044 A0	G 195	195				195		205		G 195
GN 0308 A0	GN 0652 A0	GN 1048 A0	G 200	200	5.0 ^{+0.03} _{-0.05}	0.9 ^{±0.06}	6.0 ^{±2.0}	200	+0.30	210	0	G 200
GN 0313 A0	GN 0657 A0	GN 1055 A0	G 210	210				210	0	220	-0.30	G 210
GN 0317 A0	GN 0661 A0	GN 1061 A0	G 220	220				220		230		G 220
GN 0321 A0	GN 0665 A0	GN 1067 A0	G 230	230				230		240		G 230
GN 0324 A0	GN 0668 A0	GN 1071 A0	G 240	240				240		250		G 240
GN 0328 A0	GN 0672 A0	GN 1076 A0	G 250	250				250		260		G 250
GN 0332 A0	GN 0676 A0	GN 1081 A0	G 260	260				260		270		G 260
GN 0336 A0	GN 0680 A0	GN 1087 A0	G 270	270				270		280		G 270
GN 0340 A0	GN 0683 A0	GN 1091 A0	G 280	280				280		290		G 280
GN 0343 A0	GN 0687 A0	GN 1096 A0	G 290	290				290		300		G 290
GN 0347 A0	GN 0691 A0	GN 1101 A0	G 300	300				300		310		G 300

NOK SP Coating O-Ring Series (Static Applications)



Material (NOK code) A305+SP F201+SP

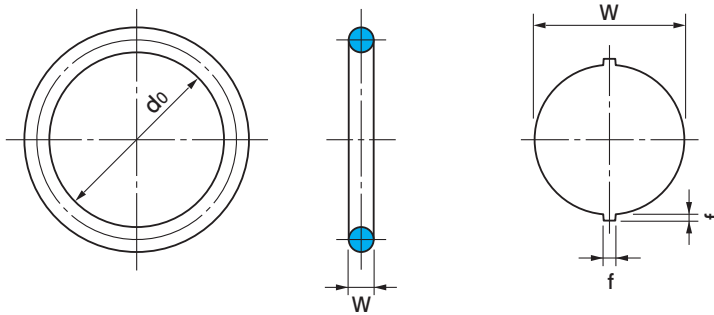

(Unit: mm)

NOK part number		NOK nominal number		O-ring dimensions					
Type Dimension code	Material code		ASP (A305+SP)	FSP (F201+SP)	Thickness W	Inside diameter do	Tolerance of inside diameter 'do'		Composite burr dimension f
	A305 +SP	F201 +SP					A305 +SP	F201 +SP	
CO 60000 CO 60001 CO 60002 CO 60003 CO 60004	A	I0	ASP 3	FSP 3	1.9±0.08	2.8	± 0.14	± 0.16	0.10 or less
		G0	ASP 4	FSP 4		3.8			
		F0	ASP 5	FSP 5		4.8	± 0.15	± 0.18	
		H0	ASP 6	FSP 6		5.8			
		G0	ASP 7	FSP 7		6.8	± 0.16	± 0.19	
		I0	ASP 8	FSP 8		7.8			
		F0	ASP 9	FSP 9		8.8	± 0.17	± 0.20	
K0	ASP 10	FSP 10	9.8						
CO 60008 CO 60009 CO 60011 CO 60012 CO 60013 CO 60014 CO 60015 CO 60016 CO 60017	A	G0	ASP 10A	FSP 10A	2.4±0.09	9.8	± 0.18	± 0.21	0.12 or less
		E0	ASP 11	FSP 11		10.8			
		F0	ASP 12	FSP 12		11.8	± 0.19	± 0.22	
		H0	ASP 12.5	FSP 12.5		12.3			
		J0	ASP 14	FSP 14		13.8	± 0.20	± 0.24	
		G0	ASP 15	FSP 15		14.8			
		H0	ASP 16	FSP 16		15.8	± 0.21	± 0.25	
		N0	ASP 18	FSP 18		17.8			
		J0	ASP 20	FSP 20		19.8	± 0.22	± 0.26	

Note:

- The SP Coating O-Ring Series is a series that has been designed in compliance with the JIS B 2401-1 P Series and to which a silicone film coating (SP coating) has been added to the O-ring surface.
- The characteristics of the SP coating are given below.

Characteristics

- The reactive functional groups of the surface coating agent react with the rubber surface molecules to form an ultra-thin, non-adhesive layer and low-friction surface.
 - This colorless, transparent coating is ultra-thin, with a thickness that measures **a few microns**.
 - The SP coating does not affect the physical properties of the rubber material.
 - The SP coating will continue to maintain its low-friction properties even after heat aging and fluid immersion testing.
- *Satin finish treatment is applied for this series.

- They are designed with dimensions that conform with the JIS B 2401-1 P Series.
- Please refer to page 23 for details on groove dimensions.
- This series is not recommended for use in dynamic applications.

When ordering, please make sure to specify both the

- NOK nominal number and
 - NOK part number.
- Ex.1) If you wish to purchase a part with an inside diameter of 7.8 and thickness of 1.9 made of material A305+SP:
 • NOK part number: **CO 60005 A**
Type/dimension code Material code
- Ex.2) If you wish to purchase a part with an inside diameter of 7.8 and thickness of 1.9 made of material F201+SP:
 • NOK part number: **CO 60005 I0**
Type/dimension code Material code

4 Features of SP Coating O-Rings



Non-adhesive Low-friction No lubricant required Anti-static

The 4 features of SP Coating O-Rings provide the following 4 benefits:

Improved workability Improved productivity Reliable quality Improved on-site cleanliness



16. O-Ring Surface Treatment Technology

NOK also offers other forms of O-ring surface treatment to meet the needs of your intended use. Please inquire separately if you are interested.

Table 7-1

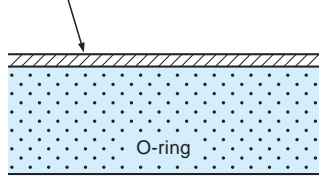
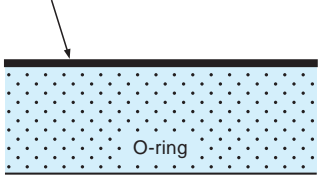
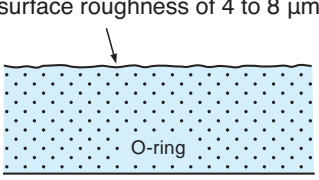
Surface treatment/ Name	Rareflon coating 11CF (gray)	Silicone film coating SP	Satin finish treatment
Structure	Rareflon (5 to 20 μm) 	Thin film formed by chemical reaction (a few microns) 	Microscopic indentations are formed on the O-ring surface (surface roughness of 4 to 8 μm) 
Friction coefficient*	0.1	0.1	1 or more (same as typical rubber)
Base material (rubber) and coating adhesion	\triangle	\circ	—
Intended use	Improvement of non- adhesion between mating surface and O-ring	\odot	—
	Reduction of insertion force during assembly (Not appropriate for use in reciprocating applications.)	\circ	—
	Prevention of adhesion between separate O-rings	\circ	\circ

*Measured using a HEIDON friction tester.

Additional note: Depending on the type of rubber material, there are cases where individual surface treatments cannot be performed.

17. Joint O-Rings

By joining multiple O-rings, we can offer products with a diameter that measures $\phi 400$ or more. Please inquire separately if you are interested.

(1) Materials

NOK material code	A305 (black)	F201 (black)
JIS	NBR-70-1	FKM-70
Old JIS*	Class 1A compliant	Class 4D compliant

Old JIS: JIS B 2401-2005

(2) Thickness Dimensions for Available Tooling

(Unit: mm)

3	3.53	4	5.33	5.7	6
6.98	8.4	10	12	12.7	15

(3) Dimensions Offered: Inside diameter of $\phi 400$ or more.

(4) Dimensional Tolerances

- Inside diameter: The inside diameter tolerance for both NBR-70-1 and FKM-70 is $\pm 1\%$.
- Thickness: Thickness tolerances are shown below:

(Unit: mm)

Thickness dimensions	A305 (NBR-70-1)	F201 (FKM-70)
From $\phi 3.00$ to $\phi 5.70$	± 0.15	± 0.20
More than $\phi 5.70$ to $\phi 8.40$	± 0.25	± 0.25
More than $\phi 8.40$ to $\phi 11.0$	± 0.30	± 0.30
More than $\phi 11.0$ to $\phi 17.0$	± 0.50	± 0.50

18. Chemical/Solvent Resistance Material “FP64”

NOK offers its “FP64 material” as a rubber material with superior chemical and solvent resistance.

(1) Dimensions Offered

NOK offers products for the JIS dimension code P/G Series and AS standard.

Additionally, we also offer products measuring \varnothing 400 or more.

(2) Characteristics

- This material has solvent resistance that is equivalent to that of FFKM (perfluoroelastomer).
- It also has superior resistance to acids and alkalis.
- It has heat and cold resistance equivalent to that of typical FKM materials (fluororubber).
- It does not contain any heavy metals*.
(*Heavy metals are defined as metals possessing a higher density than vanadium “V” in the periodic table.)
- It is suitable for use in locations where chemicals and solvents are used, such as places where chemicals, oils, paint equipment, pharmaceuticals, or office automation equipment are handled.

(3) General Properties

Table 8-1

NOK material code	FP64 (black)
1. Standard physical properties	
Hardness (durometer A)	70
Tensile strength (MPa)	15.7
Elongation (%)	190
2. Compression set	175°C×22h
(%)	22
3. Low temperature performance	
TR ₁₀ value (°C)	-10

(4) Rate of Volume Change for Various Chemical Fluids (Actual Values)

Table 8-2 shows the actual measured values for the rate of volume change for typical chemical fluids.

Table 8-2

Type of fluid	Temperature (°C)	Time (h)	General purpose FKM fluororubber	FFKM perfluoroelastomer	FP64	
Acids/alkalis	Acetic acid (98%)	118	70	110	10	27
	Nitric acid (60%)	86	70	50	5	11
	Sulfuric acid (90%)	95	168	12	5	3
	Thermal phosphoric acid (85%)	160	168	55	4	0
	Hydrofluoric acid (2%)	23	720	n.t	5	4
	Sodium hydroxide (30%)	100	70	Decomposition	5	0
	Potassium hydroxide (30%)	150	70	Decomposition	4	12
	Ammonia: NH ₄ OH (2%)	23	720	n.t	3	2
Solvents	Acetone	20	168	200 or more	10	25
	Xylene	25	168	n.t	5	5
	MEK (methyl ethyl ketone)	20	168	200 or more	7	25
	Butyl acetate	125	70	200 or more	13	31
	Dibutyl ether	25	168	85	3	5
	Methyl t-butyl ether	23	70	120	17	26
	Toluene	23	70	11	2	4
	THF (tetrahydrofuran)	20	168	200 or more	11	28
Dichloromethane	20	168	25	9	12	

- n.t: Not tested
- The values shown in the table indicate rate of volume change (%).
- The actual values shown above are not guaranteed values.

19. Klüber Lubricants for Sealing

Together with Klüber Lubrication München SE & Co. KG, a German company with 100 years of history as a supplier of specialized lubricants, NOK has established NOK KLÜBER CO., LTD. as a joint venture for providing Klüber lubricants for use in sealing applications.

NOK KLÜBER CO., LTD. carries on the technologies passed down through generations by both companies, and it leverages its proven track record and broad range of knowledge obtained through its extensive testing to provide a wide range of lubrication solutions.

Based on its abundant wealth of knowledge on a multitude of lubricants that it has built up throughout the years, NOK KLÜBER CO., LTD. is ready to meet the needs of its customers for the most demanding of conditions, such as for high-temperature, low-temperature, high-speed, and high-load bearing applications.

Types of NOK KLÜBER Lubricants

- **Lubricants for general machine parts**

For use with rolling bearings, plain bearings, chains, gears, valves, etc.

- **Lubricants for specialized applications**

For use in oxygen, vacuum, sliding surface, food processing machinery, textile machinery, and various conveyor applications

- **Other specialized lubricants**

Fluorinated lubricants, silicone-based lubricants, solid lubricants, specialized mold releasing agents, anti-rust agents, and sealing lubricants

For more details, please refer to Cat. No. 910 in the Specialized Lubricant Catalog.

List of Klüber Lubricants for Sealing

Table 9-1

Application	Name of grease	Compatibility with rubber ⁽¹⁾					Usage temperature range (°C)	Consistency (NLGI grade)	Usage examples	Features
		Nitrile rubber	Acrylic rubber	Silicone rubber	Fluororubber	Ethylene polypropylene rubber				
General use	SEALUB S-1	○	○	○	○	×	-30 - 120	2	Automobiles, construction machinery, agricultural machinery, etc.	General-purpose lubricants for rubber
Water resistance	SEALUB S-8	○	○	×	○	○	-45 - 160	3	Automobiles, household goods/equipment, etc.	Excellent water and steam resistance
Low temp./high-speed	SEALUB S-14	○	○	○	○	×	-50 - 150	2	Automobiles, household electrical appliances, industrial machinery, etc.	Can widely be used for low to high temp. applications
Assembly	SEALUB L101	○	○	○	○	○ ⁽²⁾	-30 - 90	—	Assembly and insertion of various sealed parts, etc.	Quick-drying wax and spray products for assembly
Adhesion prevention	Klüber L604	○	○	○	○	○	-25 - 260	Oil	Assembly and adhesion prevention treatment of various sealed parts, etc. Lubrication of electrical contacts and plastic parts, high-temperature sliding parts	Fluorinated oil for high-temperature use, adhesion prevention oil, spray products
Food processing machinery	Klübersynth UH1 64-2403	○	○	○	○	×	-10 - 140	3	Manufacturing equipment for food and beverages	Excellent water and steam resistance NSF H1* registered
	PARALIQ GTE 703	○	○	×	○	○	-50 - 150	3		
High temp., solvent and chemical resistance	BARRIERTA L 55/2 H1	○	○	○	○	○	-30 - 260	2	Automobiles, chemical plant equipment, etc.	Highly superior heat, solvent, and chemical resistance NSF H1* registered

Note (1): Compatibility with rubber:

○: Compatible
×: Not compatible

Since compatibility with rubber as shown here is assessed based on typical testing conditions, please make sure to verify compatibility under the usage conditions in advance of usage.

Note (2): Data shown here is only applicable to the active ingredients of the material.

*NSF H1 lubricants:

These lubricants can be used in locations for which incidental contact with food products is unavoidable.

20. Reference Materials - Actual Data, Blooming, Swelling, Failure Mode Case Studies, Etc. -

*Since data shown in this section is based on NOK test data, they do not represent guaranteed values.

(1) Compression Set Testing Method

As is most common for such testing, compression set testing is carried out in accordance with JIS K 6262 (physical testing method for vulcanized rubber).

For this test, however, for test samples with a large inside diameter, we cut such O-rings to a length of about 40 mm and secure them in a compression set testing jig and used spacers to ensure a constant compression ratio as shown in Figure 6-1. After keeping the jig in a chamber heated to a specified temperature, we periodically remove the O-rings and use a dial gauge to measure their compression set over time.

Compression set is calculated in accordance with JIS standards.

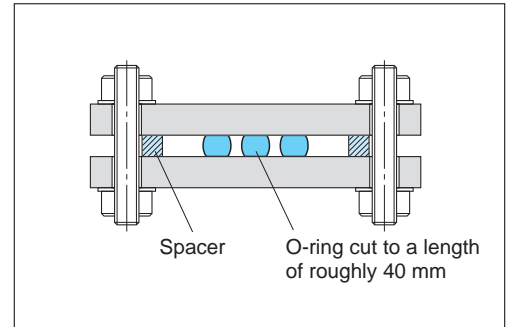

Fig. 6-1

(2) Surface Roughness and Sealing Performance

Changes in surface roughness will impact O-ring sealing performance.

- **Product type and dimensions:** OR 21.8×2.4 (OR NBR-70-1 P22-N) Material: A305 (JIS NBR-70-1)
- **Test conditions:** Pressure: 3 MPa, Temp.: Room temperature,
Time: 2 min. of pressurization time, Compression ratio: 25%
(NOK recommended values are used for O-ring mating groove dimensions.)

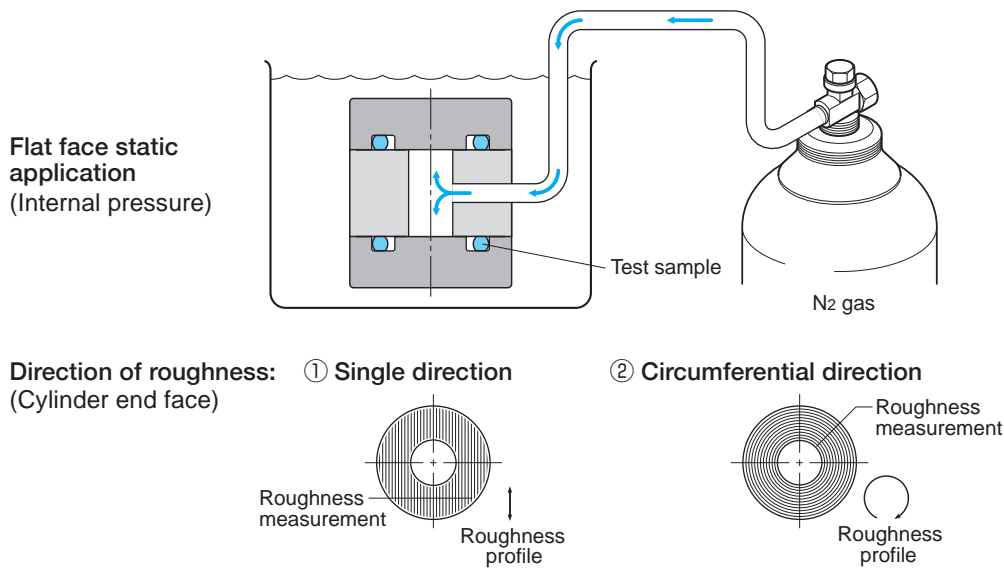

Fig. 6-2 [Jig Schematic]

- **Test results** (presence of leakage and leakage pressure)

Table 10-1

○: No leakage ×: Leakage

Sealing surface roughness (Rz)		5 μm	6 μm	8 μm	10 μm	14 μm
Direction of roughness	① Single direction	○	○	○	○	×
	② Circumferential direction	○	○	○	○	○

Rz: Maximum roughness height

- **Summary of test results**

(1) For surface roughness in a single direction, leakage occurs at a sealing surface roughness of 14 μm (Rz).

(2) For surface roughness in a circumferential direction, leakage does not occur even at a sealing surface roughness of 14 μm.

With that said, however, since sealing performance will differ depending on roughness profile and usage conditions, please perform surface finishing to obtain a roughness as shown in Table 5-2 on page 14.

(3) O-Ring Compressive Stress Reaction Force

Since O-rings are compressed when they are being used, the O-ring itself will generate a reaction force (compressive stress reaction force).

O-ring compressive stress reaction force will be exerted as shown in Fig. 6-3. Please refer to this as a rough guide for determining tightening load for flanges. Furthermore, compressive stress reaction force will vary depending on such factors as rubber hardness, compression ratio, and O-ring dimensions.

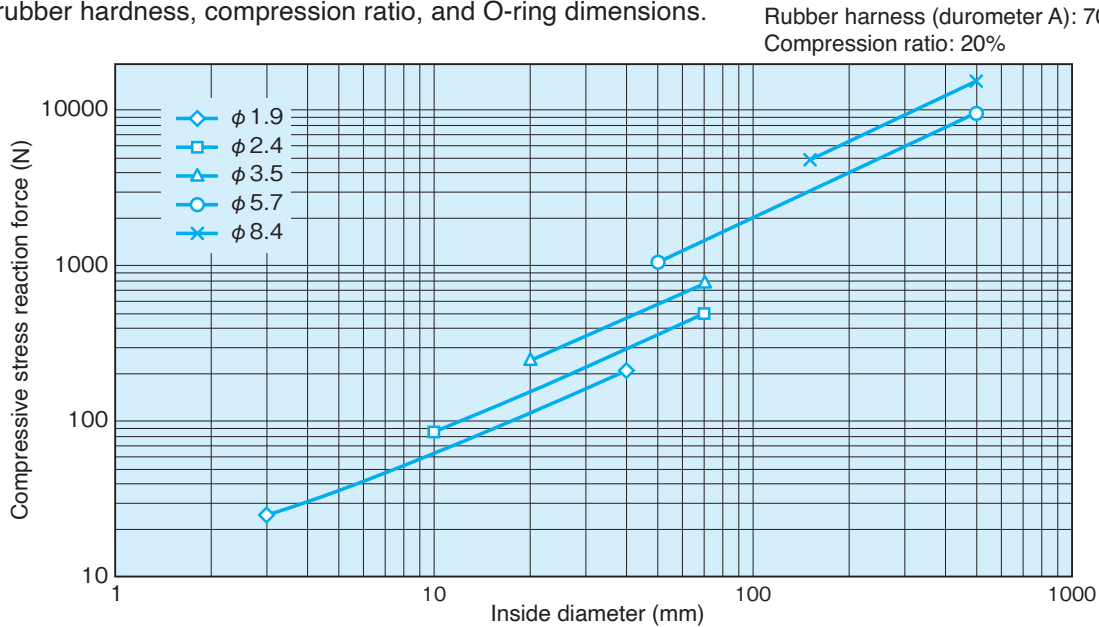

Fig. 6-3 O-Ring Compressive Stress Reaction Force

(4) O-Ring Sliding Resistance

When using O-rings in dynamic applications, sliding resistance will significantly impact the efficiency of the equipment. Since O-ring sliding resistance will be impacted by such factors as compression value, machining precision of rods or cylinders, pressure, sliding speed, lubrication conditions, temperature, hardness, and diameter dimensions, this value is difficult to express in general terms.

Fig. 6-4 provides a guide on kinetic friction for the standard dimensions of JIS P Series O-rings (durometer hardness of A70).

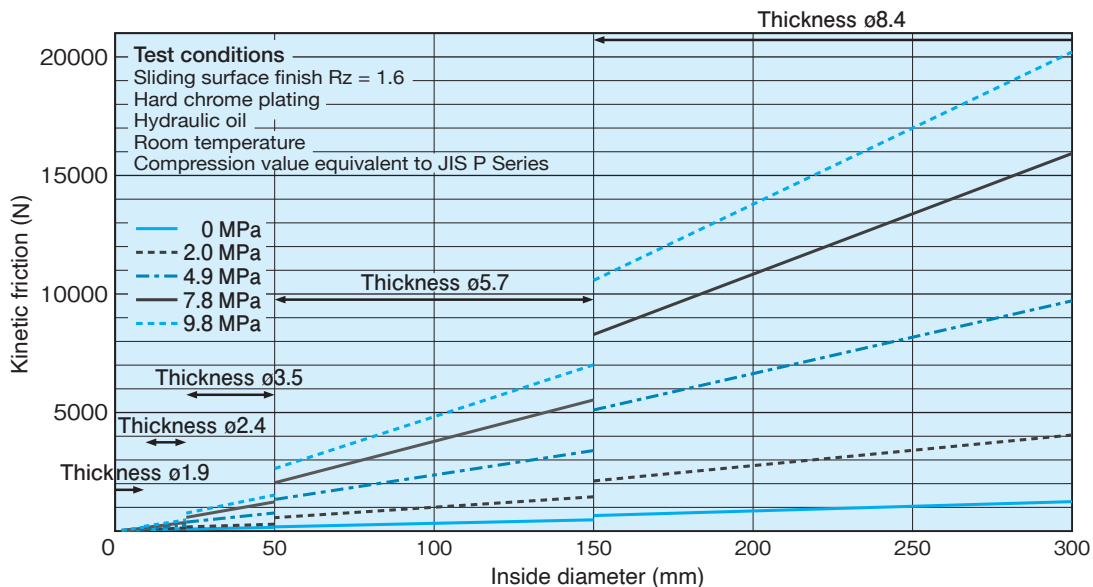

Fig. 6-4 O-Ring Kinetic Friction

Furthermore, there are two types of friction, “startup and kinetic,” and the values for startup friction are significantly higher than that for kinetic friction. Since sliding resistance and lifespan for O-rings for dynamic applications are severely impacted by lubrication conditions, it will be necessary to apply adequate lubrication for cases that involve air sealing.

(5) Relationship Between O-Ring Compression Ratio and Compression Set

Data
 Environment: Exposed to air
 Temperature: ① 80°C
 ② 100°C
 ③ 120°C
 Thickness: 3.5 mm
 Time: 70 h

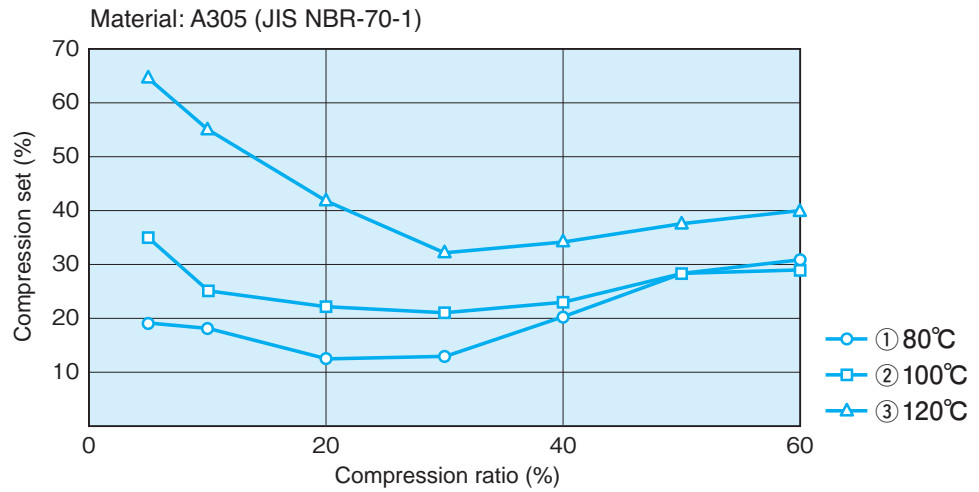

Fig. 6-5

(6) O-Rings for Pneumatic Dynamic Sealing (Friction Characteristics)

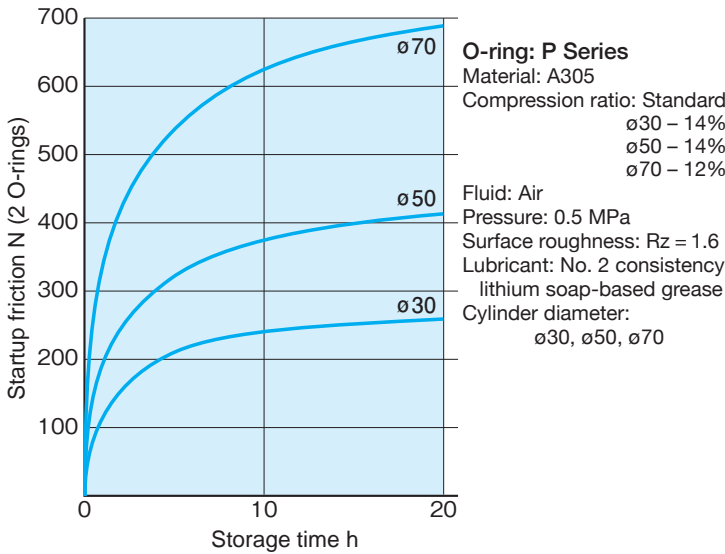

Fig. 6-6 Relationship Between Storage Time and Startup Friction

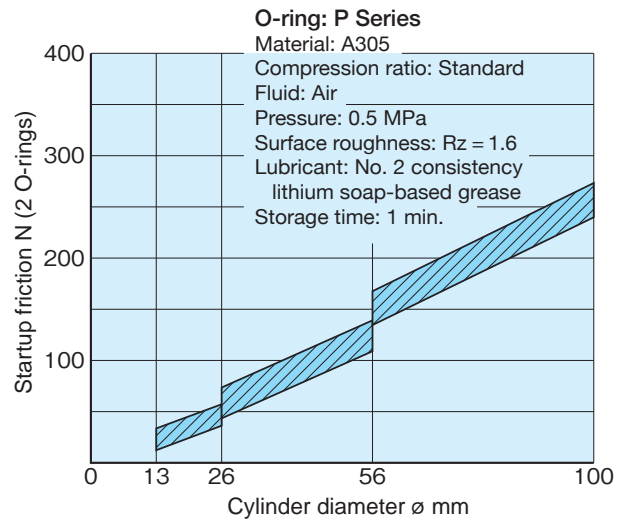

Fig. 6-7 Relationship Between Cylinder Diameter and Startup Friction

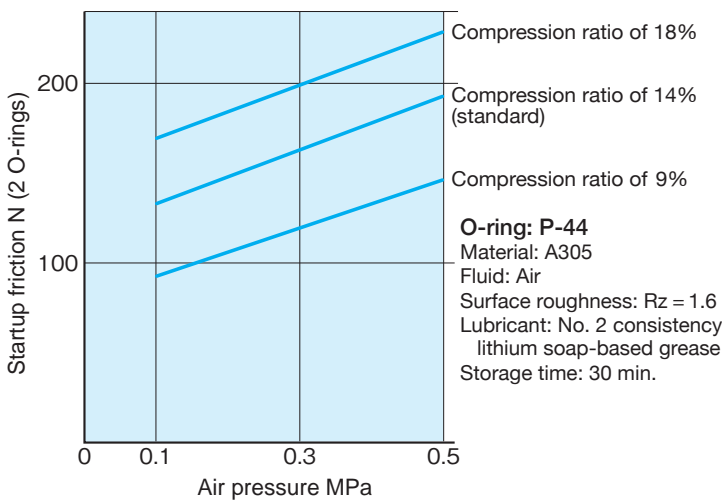

Fig. 6-8 Relationship Between Air Pressure and Startup Friction

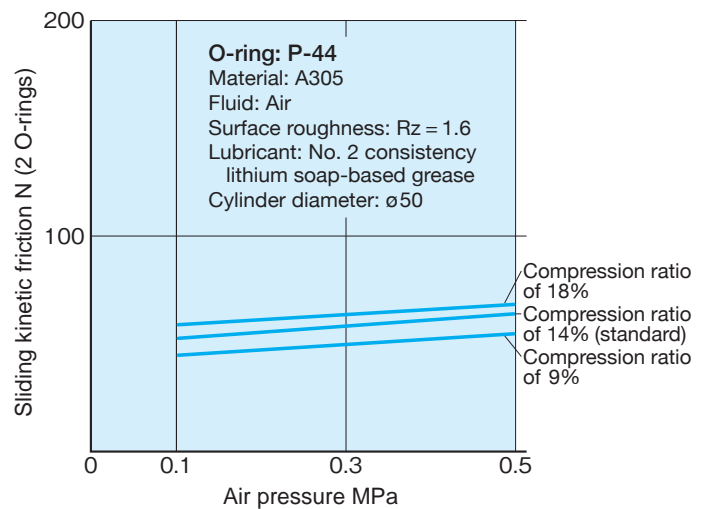

Fig. 6-9 Relationship Between Air Pressure and Sliding Kinetic Friction

(7) Blooming (Bloom)

Blooming refers to a phenomenon where substances precipitate and cover the surface of an O-ring due to migration of the compound agent from inside of uncured or vulcanized rubber, and anti-aging chemicals, such as sulfur and paraffin cause such blooming to more readily occur.

There are cases where blooming can be made to occur intentionally using rubber compounding technologies (to improve ozone resistance), as well as cases where such blooming can be incidental.

As shown in Fig. 6-10^{*1}, the causes of this phenomenon are as follows:

1) Low solubility (solubility between rubber and compounding agents)

2) High mobility (chemical mobility of compounding agents within rubber)

In addition to these 2 factors, the following factor can also be given:

3) Differences in blooming substance concentration between the rubber surface and interior

However, since numerous compounding agents are used within a rubber product, and since blooming is induced and derived through the interactions between such agents, this relationship cannot be illustrated using a model as simple as that shown in Fig. 6-10^{*2}.

Additionally, differences in concentration of blooming substances are impacted by such factors as evaporation/volatilization of blooming substances and oxidation of the rubber surface caused by air^{*3}.

There are also cases where blooming due to rubber oxidation can occur in a matter of a few hours after being exposed to air.

In regards to blooming, our current understanding is based solely on experiential knowledge, and a complete theoretical explanation for this phenomenon has not yet been discovered.

Some observations based on such experiential knowledge are given below^{*2}:

- a) Direct exposure to light, especially short-wavelength fluorescent light, tends to cause blooming.
- b) Friction and exposure of the rubber surface to wind tend to cause blooming.
- c) Blooming occurs in the shape of a fingerprint after the surface has been touched.

(Dictionary of Polymer Technology, Taiseisha Ltd.)

*1.A.K.BHOWMIC.and S.K.DE., *Rubber Chem.Tech.*, Vol. 52, 52, 976 (1979)

*2 Kaneko, H., *Applied Theory on the Physical Properties of Rubber*, No. 16, P 268, The Society of Rubber Science and Technology, Japan

*3 Urabe, N. and Sakaguchi F., *Polymer no Tomo*, Vol. 3, 227 (1966)

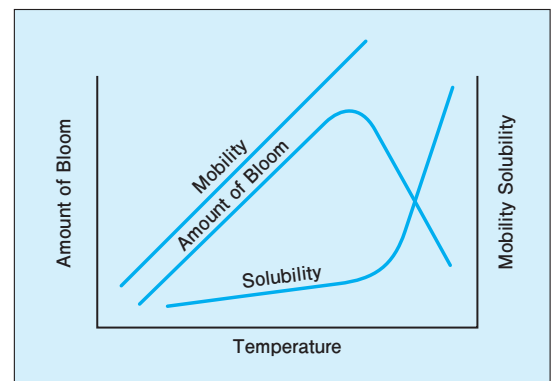
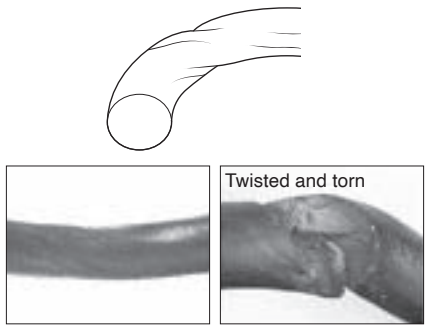
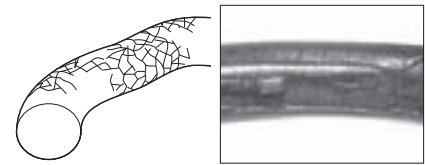
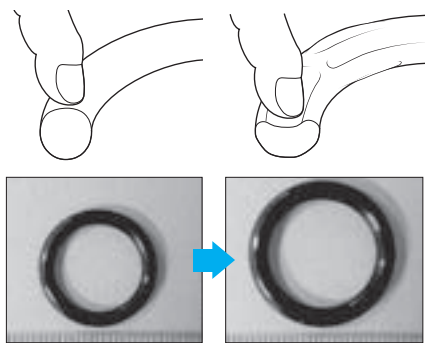
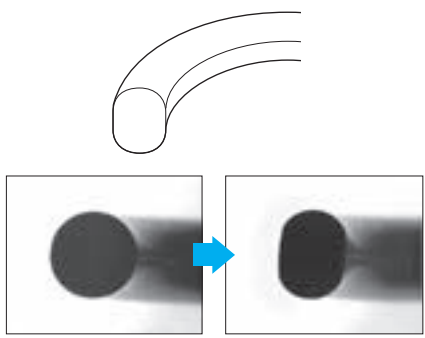
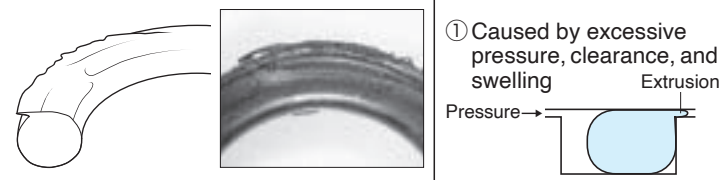

Fig. 6-10

(7) Failure Modes and Countermeasures

In the event that leakage occurs, please refer to the following table when examining the failed part to identify the root cause and to determine a countermeasure.

Table 10-2

Appearance		Phenomenon	Condition
Root cause	Countermeasure		
Twisting	O-ring is twisted and deformed	 <p>*Tearing that occurs due to heavy twisting</p>	<ul style="list-style-type: none"> ① Movement is too fast ② Subjected to eccentric movement ③ Uneven sliding surface roughness ④ Installed in a twisted condition <ul style="list-style-type: none"> ① Replace with a D-ring, X-ring, or lip packing ② Eliminate eccentric movement ③ Improve sliding surface roughness ④ Install carefully (apply grease, etc.)
Hardening	Hardened and cracking occurs when bent		<ul style="list-style-type: none"> ① Usage temperature exceeds the heat resistance limits of the rubber material <ul style="list-style-type: none"> ① • Lower the environmental temperature • Change to a material with superior heat resistance
Swelling (softening)	Exhibits overall softness and excessive swelling		<ul style="list-style-type: none"> ① Rubber material is not suitable for the sealing medium ② In some cases, this can be caused by residual cleaning agents left on the hardware after cleaning with diesel fuel or gasoline <ul style="list-style-type: none"> ① Consider using a different rubber material ② Ensure that cleaning agent is completely removed
Permanent deformation	O-ring cross-section has been deformed to the shape of the groove		<ul style="list-style-type: none"> ① • Excessive compression • High temperatures • Sealing medium <p>In most cases, this is caused by an interaction between these different factors</p> <ul style="list-style-type: none"> ① Consider changing the groove dimensions and materials Cool the area around the seal
Extrusion	Entire (or partial) circumference of O-ring outer periphery or inner periphery is torn		<ul style="list-style-type: none"> ① Caused by excessive pressure, clearance, and swelling <ul style="list-style-type: none"> ① • Ensure proper clearance or use backup rings • Consider using a different rubber material

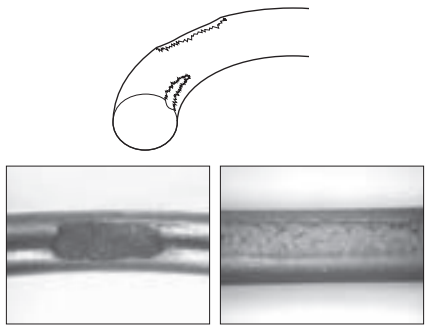
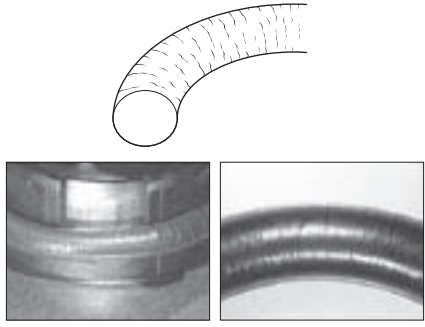
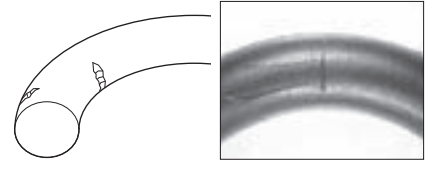
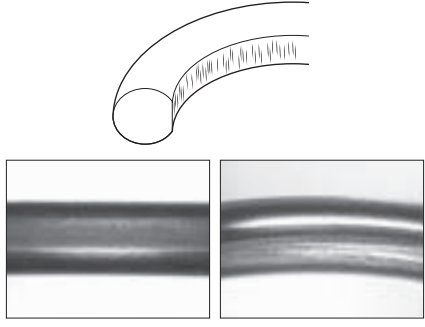
Appearance		Phenomenon	Condition
Root cause	Countermeasure		
Scraping/ gouging	O-ring outer periphery or inner periphery is torn off or partially gouged out in proportion with the compression value 	<ol style="list-style-type: none"> ① Forced assembly for cylinder edges or shaft edges with inadequate chamfering ② Forced installation for O-ring groove that is shallower than standard dimensions when compared to O-ring thickness ③ Damage caused during installation to such portions as holes, screws, or edges 	<ol style="list-style-type: none"> ① Perform appropriate chamfering ② Consider using different groove dimensions ③ Pay careful attention to chamfering for edges and use an installation jig
Ozone cracking	Cracking fissures are exhibited across the entire O-ring surface 	<ol style="list-style-type: none"> ① O-ring has been exposed to air while in an elongated condition, thereby resulting in cracking due to the effects of ozone 	<ol style="list-style-type: none"> ① • Do not leave O-rings exposed to air while in an elongated condition • Apply grease or oil to the O-ring surface and make sure it is not directly exposed to air
Scratching	Scratching due to rubbing has occurred for the O-ring outer periphery or inner periphery 	<ol style="list-style-type: none"> ① O-ring inner (outer) periphery has been scratched by screw threads, etc., during O-ring installation 	<ol style="list-style-type: none"> ① Use a protective jig that prevents O-rings from coming into direct contact with screw threads, etc., during installation
Wear	Wear is exhibited for the O-ring contacting portions 	<ol style="list-style-type: none"> ① If surface finishing for the mating surface that comes into contact with the O-ring is rough, friction will be generated due to pressure fluctuations ② Insufficient lubrication ③ Foreign substances, such as dust or metal powder have been introduced 	<ol style="list-style-type: none"> ① Ensure that the roughness of the mating surface that comes into contact with the O-ring meets the standards ② Improve lubrication conditions ③ Remove foreign substances and use a filter or dust seal

(7) Swelling Mechanisms

(1) What is Swelling?

Swelling refers to a condition where oil molecules are allowed to penetrate in between polymer molecules, and where the forces trying to expand the intermolecular space reach an equilibrium with the elasticity of the cross-linked network of polymers.

Furthermore, the size of swelling is dependent upon the affinity between the oil and the polymer, and the higher the affinity between these two substances, the larger the swelling that will occur.

SP values (Solubility Parameter; the closer the polarity the higher the affinity) are often used as a rough standard to indicate affinity, and it can be said that substances with similar molecular structures exhibit higher affinity.

[Ex. 1] EPDM and mineral oil (high affinity) → Large swelling

EPDM	Mineral oil
SP value: 8 (low polarity)	SP value: 6 to 8 (low polarity)
$[\text{CH}_2-\text{CH}_2]_n[\text{CH}-\text{CH}_2]_m$ $\quad\quad\quad $ $\quad\quad\quad \text{CH}_3$	$\text{C}_n\text{H}_{2n+2}$

→ Since EPDM and mineral oil have similar structures (only C and H have no polar group) and exhibit high affinity, swelling will be large.

[Ex. 2] NBR and mineral oil (low affinity) → Small swelling

NBR	Mineral oil
SP value: 9 to 10 (high polarity)	SP value: 6 to 8 (low polarity)
$[\text{CH}_2-\text{CH}=\text{CH}-\text{CH}_2]_n[\text{CH}-\text{CH}_2]_m$ $\quad\quad\quad $ $\quad\quad\quad \text{C}\equiv\text{N} \leftarrow \text{Polar group}$	$\text{C}_n\text{H}_{2n+2}$

→ Since NBR and mineral oil have dissimilar structures (NBR has a polar group) and exhibit low affinity, swelling will be small.

(2) Progression of Swelling

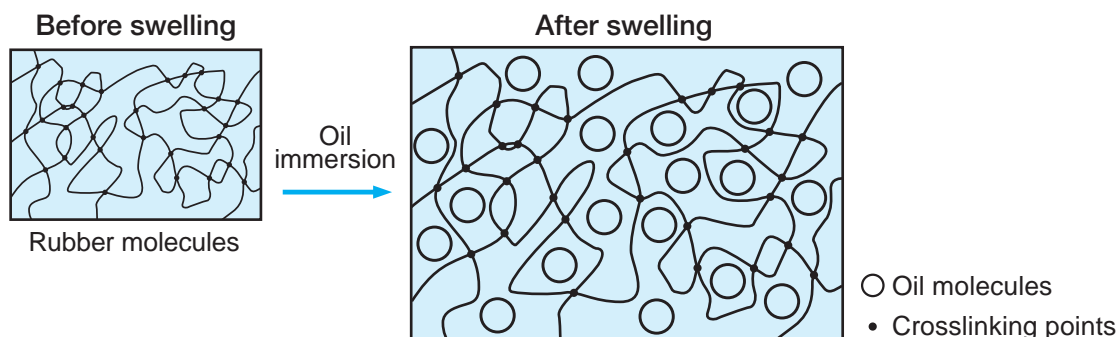

20

Oil intrudes in between the rubber molecules and tries to expand the space between the rubber molecules (swelling phenomenon). Although oil swelling will cause the space between the rubber molecules to expand, since crosslinking has occurred, swelling will only progress to a certain degree (swelling equilibrium).

[Reference: For non-crosslinked rubber, swelling will continue to increase and will ultimately result in dissolution (rubber-based adhesives and spray adhesives, etc.).]

Please refer to pages 8 and 9 for more details on affinity between the various materials and fluids.

Ex.) ○ ... Suitable for usage (low affinity)

× ... Not suitable for usage (high affinity)

21. O-Ring Groove Dimensions for Standards with No Groove Indications

For more details on groove dimensions, please refer to the dimension tables for each of the individual product types. Since the groove dimensions for the old ARP568, AS568 Series, and ISO Equivalent General Industrial Series are not specified by AS standards or ISO standards, please refer to the following when using these products. Additionally, please make sure to refer to the reference materials that are listed starting from this page.

Old ARP568 and AS568 Series } Method for determining ISO Equivalent General Industrial Series } groove dimensions

[Procedure]

1. Determining compression ratio Usage range: 8 to 30%

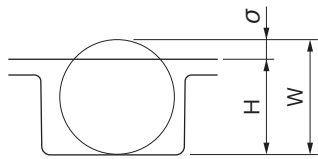

$$E = \frac{\sigma}{W} \times 100$$

E (%) : Compression ratio
 σ (mm): Compression value (= W-H)
 W (mm): O-ring thickness
 H (mm): Groove depth

2. Determining filling ratio Usage range: Max. value 90%, median value 75% (design target values)

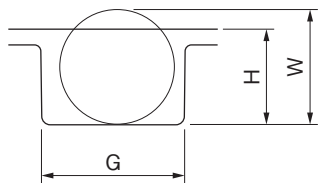

$$n = \frac{\pi/4 \times W^2}{G \times H} \times 100$$

n (%) : Filling ratio
 G (mm): Groove width
 W (mm): O-ring thickness
 H (mm): Groove depth

[Reference materials] Please refer to the following reference materials on groove dimensions.

(1) For the (ISO Equivalent) General Industrial Series (based on JIS B 2401-2)

Table 11-1 Groove Dimensions for Cylindrical Surface Sealing Applications (for static use) (Unit: mm)

O-ring thickness	Groove width ^{+0.25} ₀	Groove depth		Groove bottom r1	Groove corners r2
		For pistons	For rods		
1.80 ± 0.08	2.4	1.38	1.42	0.2 - 0.4	0.1 - 0.3
2.65 ± 0.09	3.6	2.07	2.15	0.2 - 0.4	0.1 - 0.3
3.55 ± 0.10	4.8	2.74	2.85	0.4 - 0.8	0.1 - 0.3
5.30 ± 0.13	7.1	4.19	4.36	0.4 - 0.8	0.1 - 0.3
7.00 ± 0.15	9.5	5.67	5.89	0.8 - 1.2	0.1 - 0.3

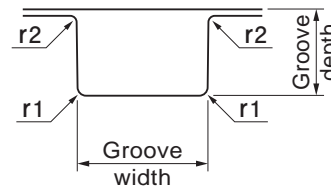

Table 11-2 Groove Dimensions for Cylindrical Surface Sealing Applications (for dynamic use) (Unit: mm)

O-ring thickness	Groove width ^{+0.25} ₀	Groove depth*		Groove bottom r1	Groove corners r2
		For pistons	For rods		
1.80 ± 0.08	2.4	1.42	1.47	0.2 - 0.4	0.1 - 0.3
		2.2	1.57		
2.65 ± 0.09	3.6	2.16	2.24	0.2 - 0.4	0.1 - 0.3
		3.4	2.37		
3.55 ± 0.10	4.8	2.96	3.07	0.4 - 0.8	0.1 - 0.3
		4.6	3.24		
5.30 ± 0.13	7.1	4.48	4.66	0.4 - 0.8	0.1 - 0.3
		6.9	4.86		
7.00 ± 0.15	9.5	5.95	6.16	0.8 - 1.2	0.1 - 0.3
		9.3	6.43		

*Upper row: For hydraulic applications, Bottom row: For pneumatic applications

Table 11-3 Groove Dimensions for Flat Face Static Sealing Applications (Unit: mm)

O-ring thickness	Groove width ^{+0.25} ₀	Groove depth	Groove bottom r1	Groove corners r2
1.80 ± 0.08	2.6	1.28	0.2 - 0.4	0.1 - 0.3
2.65 ± 0.09	3.8	1.97	0.2 - 0.4	0.1 - 0.3
3.55 ± 0.10	5.0	2.75	0.4 - 0.8	0.1 - 0.3
5.30 ± 0.13	7.3	4.24	0.4 - 0.8	0.1 - 0.3
7.00 ± 0.15	9.7	5.72	0.8 - 1.2	0.1 - 0.3

(2) For the AS568 Series (based on MIL-G-5514G)

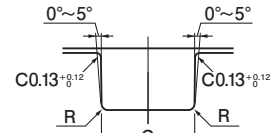

Groove Shapes

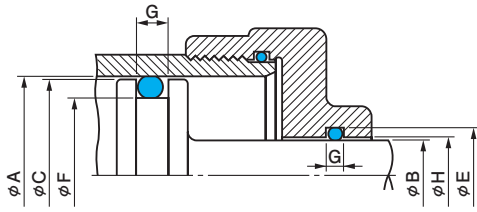

For Dynamic Applications

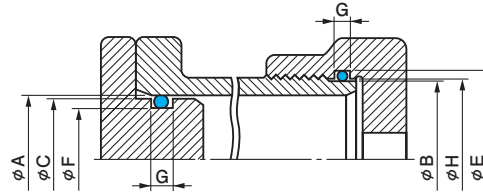

For Cylindrical Surface Static Applications

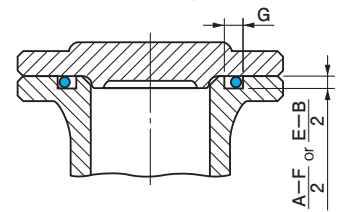

For Flat Face Static Applications

(Unit: mm)

MS28775 nominal dimensions	AN6227 nominal dimensions Old JIS W 1516 nominal number	AN6230 nominal dimensions Old JIS W 1517 nominal number	C	A	F	B	H	E	R	G No backup rings	
001			2.36	2.42	0.83	0.83	0.89	2.42	0.38 0.13	1.60	
			2.34	2.43	0.82	0.82	0.91	2.43		1.85	
002			3.20	3.26	1.21	1.21	1.27	3.26		1.86	
			3.18	3.27	1.20	1.20	1.29	3.27		2.10	
003			3.98	4.04	1.60	1.60	1.66	4.04		2.11	
			3.97	4.06	1.58	1.58	1.67	4.06		2.36	
004			4.77	4.83	1.93	1.93	1.99	4.83		2.39 2.64	
			4.75	4.85	1.91	1.91	2.00	4.85			
005			5.56	5.62	2.74	2.74	2.80*	5.62			
			5.54	5.63	2.72	2.72	2.81*	5.63			
006	1		5.91	5.97	3.12	3.12	3.18	5.97			
			5.90	5.99	3.10	3.10	3.20	5.99			
007	2		6.70	6.76	3.91	3.91	3.97	6.76			
			6.68	6.78	3.89	3.89	3.98	6.78			
008	3		7.49	7.55	4.69	4.69	4.75	7.55			
			7.47	7.56	4.68	4.68	4.77	7.56			
009	4		8.30	8.36	5.51	5.51	5.57	8.36			
			8.28	8.38	5.49	5.49	5.58	8.38			
010	5		9.09	9.15	6.29	6.29	6.35	9.15			
			9.07	9.16	6.28	6.28	6.37	9.16			
011	6		10.66	10.72	7.87	7.87	7.93	10.72			
			10.65	10.74	7.85	7.85	7.95	10.74			
012	7		12.26	12.32	9.47	9.47	9.53	12.32			
			12.25	12.34	9.45	9.45	9.55	12.34			
013	Only use for static applications		13.91	13.97	11.12	11.04	11.10	13.90	0.38 0.13		2.39 2.64
13.90			14.02	11.08	11.00	11.12	13.94				
014			15.51	15.57	12.72	12.64	12.70	15.50			
			15.50	15.62	12.68	12.60	12.72	15.54			
015			17.09	17.15	14.30	14.22	14.28	17.07			
			17.07	17.19	14.25	14.18	14.30	17.11			
016			18.69	18.75	15.90	15.82	15.88	18.67			
			18.67	18.79	15.85	15.78	15.90	18.71			
017			20.26	20.32	17.47	17.39	17.45	20.25			
			20.25	20.37	17.43	17.35	17.47	20.29			
018			21.86	21.92	19.07	18.99	19.05	21.85			
			21.85	21.97	19.03	18.95	19.07	21.89			
019			23.44	23.50	20.65	20.57	20.63	23.42			
			23.42	23.54	20.60	20.53	20.65	23.46			
020			25.12	25.18	22.32	22.17	22.23	25.02			
			25.10	25.22	22.28	22.13	22.25	25.06			
021			26.69	26.75	23.90	23.74	23.80	26.60			
			26.67	26.79	23.86	23.70	23.82	26.64			
022			28.29	28.35	25.50	25.34	25.40	28.20			
			28.27	28.39	24.46	25.30	25.42	28.24			
023			29.87	29.93	27.07	26.92	26.98	29.77			
			29.85	29.97	27.03	26.88	27.00	29.81			
024			31.47	31.53	28.67	28.52	28.58	31.37			
			31.45	31.57	28.63	28.48	28.60	31.41			

*Values determined by NOK.

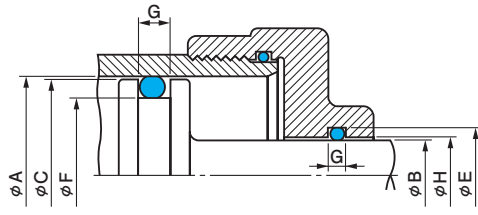
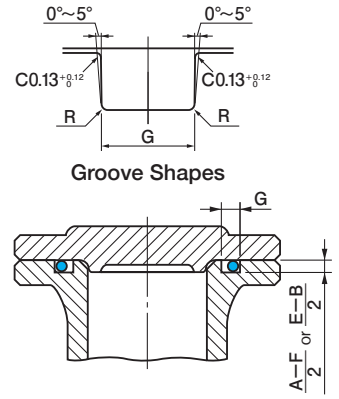

For Dynamic Applications

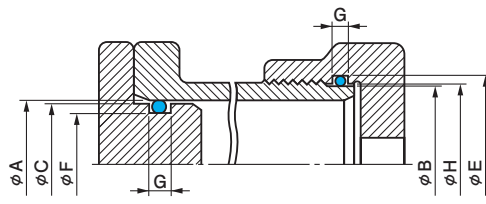

For Cylindrical Surface Static Applications

For Flat Face Static Applications

(Unit: mm)

MS28775 nominal dimensions	AN6227 nominal dimensions Old JIS W 1516 nominal number	AN6230 nominal dimensions Old JIS W 1517 nominal number	C	A	F	B	H	E	R	G No backup rings			
025	Only use for static applications		33.04	33.10	30.25	30.09	30.15	32.95	0.38 0.13	2.39 2.64			
			33.02	33.14	30.21	30.05	30.17	32.99					
026		34.64	34.70	31.85	31.69	31.75	34.55						
		34.62	34.74	31.81	31.65	31.77	34.59						
027		36.22	36.28	33.42	33.27	33.33	36.12						
		36.20	36.32	33.38	33.23	33.35	36.17						
028		37.82	37.88	35.02	34.87	34.93	37.72						
		37.80	37.92	34.98	34.83	34.95	37.77						
110		8		13.91	13.97	9.44	9.47	9.53			14.00	0.38 0.13	3.59 3.83
				13.90	14.02	9.40	9.43	9.55			14.04		
111		9		15.51	15.57	11.04	11.04	11.10			15.57		
				15.50	15.62	11.00	11.00	11.12			15.62		
112		10		17.09	17.15	12.62	12.64	12.70			17.17		
				17.07	17.19	12.58	12.60	12.72			17.22		
113	11		18.69	18.75	14.22	14.22	14.28	18.75					
			18.67	18.79	14.18	14.18	14.30	18.79					
114	12		20.26	20.32	15.79	15.82	15.88	20.35					
			20.25	20.37	15.75	15.78	15.90	20.39					
115	13		21.86	21.92	17.39	17.39	17.45	21.92					
			21.85	21.97	17.35	17.35	17.47	21.97					
116	14		23.44	23.50	18.97	18.99	19.05	23.52					
			23.42	23.54	18.93	18.95	19.07	23.57					
117	Only use for static applications		25.12	25.18	20.65	20.57	20.63	25.10					
25.10			25.22	20.60	20.53	20.65	25.14						
118			26.69	26.75	22.22	22.17	22.23	26.70					
			26.67	26.79	22.18	22.13	22.25	26.74					
119			28.29	28.35	23.82	23.74	23.80	28.27					
			28.27	28.39	23.78	23.70	23.82	28.32					
120			29.87	29.93	25.40	25.34	25.40	29.87					
			29.85	29.97	25.35	25.30	25.42	29.92					
121			31.47	31.53	27.00	26.92	26.98	31.45					
			31.45	31.57	26.95	26.88	27.00	31.49					
122			33.04	33.10	28.57	28.52	28.58	33.05					
			33.02	33.14	28.53	28.48	28.60	33.09					
123			34.64	34.70	30.17	30.09	30.15	34.62					
			34.62	34.74	30.13	30.05	30.17	34.67					
124			36.22	36.28	31.75	31.69	31.75	36.22					
			36.20	36.32	31.70	31.65	31.77	36.27					
125			37.82	37.88	33.35	33.27	33.33	37.80					
			37.80	37.92	33.30	33.23	33.35	37.84					
126			39.39	39.45	34.92	34.87	34.93	39.40					
			39.37	39.49	34.88	34.83	34.95	39.44					
127			40.99	41.05	36.52	36.44	36.50	40.97					
			40.97	41.09	36.48	36.40	36.55	41.02					
128			42.57	42.63	38.10	38.04	38.10	42.57					
			42.55	42.67	38.05	38.00	38.15	42.62					
129	44.17	44.23	39.70	39.62	39.68	44.15							
	44.15	44.27	39.65	39.58	39.72	44.19							

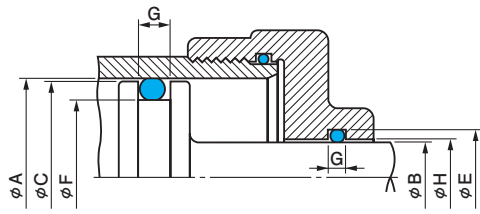

For Dynamic Applications

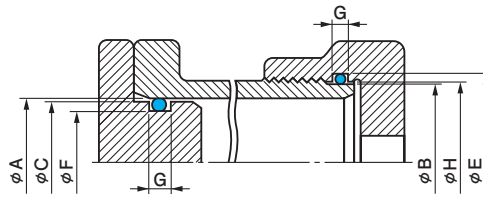

For Cylindrical Surface Static Applications

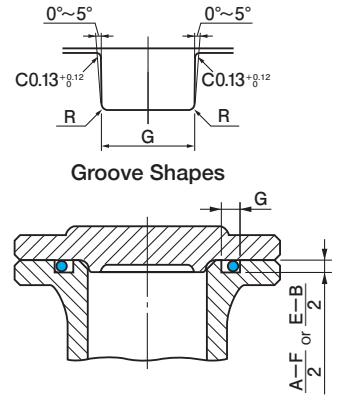

For Flat Face Static Applications

(Unit: mm)

MS28775 nominal dimensions	AN6227 nominal dimensions Old JIS W 1516 nominal number	AN6230 nominal dimensions Old JIS W 1517 nominal number	C	A	F	B	H	E	R	G No backup rings
130	Only use for static applications		45.77	45.85	41.32	41.22	41.28	45.75	0.38 0.13	3.59 3.83
			45.75	45.89	41.28	41.18	41.32	45.79		
131			47.34	47.43	42.90	42.79	42.85	47.32		
			47.32	47.47	42.85	42.75	42.90	47.37		
132			48.94	49.03	44.50	44.39	44.45	48.92		
			49.92	49.07	44.45	44.35	44.50	49.97		
133			50.52	50.60	46.07	45.97	46.05	50.50		
			50.50	50.64	46.03	45.93	46.10	50.54		
134			52.12	52.20	47.67	47.57	47.65	52.10		
			52.10	52.24	47.63	47.53	47.70	52.14		
135			53.72	53.80	49.27	49.17	49.26	53.70		
			53.70	53.84	49.23	49.13	49.30	53.74		
136			55.29	55.38	50.85	50.74	50.83	55.27		
			55.27	55.42	50.80	50.70	50.87	55.32		
137			56.89	56.98	52.45	52.34	52.43	56.88		
			56.88	57.02	52.40	52.30	53.47	56.92		
138			58.47	58.55	54.02	53.92	54.00	58.45		
			58.45	58.59	53.98	53.88	54.05	58.49		
139			60.07	60.15	55.62	55.52	55.61	60.05		
			60.05	60.19	55.58	55.48	55.65	60.09		
140	61.64	61.73	57.20	57.09	57.18	61.62				
	61.62	61.77	57.15	57.05	57.22	61.67				
141	63.24	63.33	58.80	58.69	58.78	63.23				
	63.20	63.37	58.75	58.65	58.82	63.27				
142	64.82	64.90	60.37	60.27	60.35	64.80				
	64.77	64.94	60.33	60.23	60.40	64.84				
143	66.42	66.50	61.97	61.87	61.96	66.40				
	66.37	66.54	61.93	61.83	62.00	66.44				
144	67.99	68.08	63.55	63.44	63.53	67.97				
	67.95	68.12	63.50	63.40	63.57	68.02				
145	69.59	69.68	65.15	65.04	65.13	69.58				
	69.55	69.72	65.10	65.00	65.17	69.62				
146	71.17	71.25	66.72	66.62	66.70	71.15				
	71.12	71.29	66.68	66.58	66.75	71.19				
147	72.77	72.85	68.32	68.22	68.31	72.75				
	72.72	72.89	68.28	68.18	68.35	72.79				
148	74.34	74.43	69.90	69.79	69.88	74.32				
	74.30	74.47	69.85	69.75	69.92	74.37				
149	75.94	76.03	71.50	71.39	71.48	75.93				
	75.90	76.07	71.45	71.35	71.52	75.97				
210	15		25.12	25.18	18.99	18.99	19.05	25.18	0.63 0.26	4.78 5.02
			25.10	25.22	18.95	18.95	19.07	25.22		
211	16		26.69	26.75	20.57	20.57	20.63	26.75		
			26.67	26.79	20.53	20.53	20.65	26.79		
212	17		28.29	28.35	22.17	22.17	22.23	28.35		
			28.27	28.39	22.13	22.13	22.25	28.39		
213	18		29.87	29.93	23.74	23.74	23.80	29.93		
			29.85	29.97	23.70	23.70	23.82	29.97		

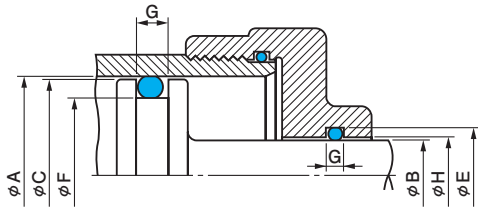
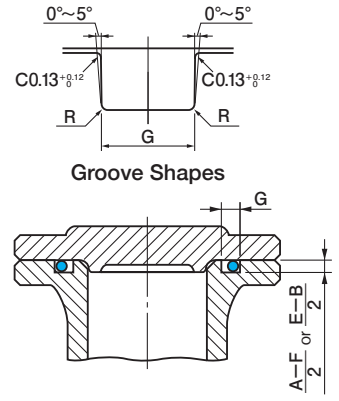

For Dynamic Applications

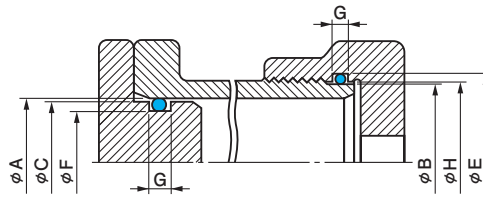

For Cylindrical Surface Static Applications

For Flat Face Static Applications

(Unit: mm)

MS28775 nominal dimensions	AN6227 nominal dimensions Old JIS W 1516 nominal number	AN6230 nominal dimensions Old JIS W 1517 nominal number	C	A	F	B	H	E	R	G
214	19		31.47	31.53	25.34	25.34	25.40	31.53	0.63 0.26	4.78 5.02
			31.45	31.57	25.30	25.30	25.42	31.57		
215	20		33.04	33.10	26.92	26.92	26.98	33.10		
			33.02	33.14	26.88	26.88	27.00	33.14		
216	21		34.64	34.70	28.52	28.52	28.58	34.70		
			34.62	34.74	28.48	28.48	28.60	34.74		
217	22		36.22	36.28	30.09	30.09	30.15	36.28		
			36.20	36.32	30.05	30.05	30.17	36.32		
218	23		37.82	37.88	31.69	31.69	31.75	37.88		
			37.80	37.92	31.65	31.65	31.77	37.92		
219	24		39.39	39.45	33.27	33.27	33.33	39.45		
			39.37	39.49	33.23	33.23	33.35	39.49		
220	25		40.99	41.05	34.87	34.87	34.93	41.05		
			40.97	41.09	34.83	34.83	34.95	41.09		
221	26		42.57	42.63	36.44	36.44	36.50	42.63		
			42.55	42.67	36.40	36.40	36.52	42.67		
222	27		44.17	44.23	38.04	38.04	38.10	44.23		
			44.15	44.27	38.00	38.00	38.12	44.27		
223	Only use for static applications	1	47.34	47.43	41.24	41.22	41.28	47.40		
47.32			47.47	41.20	41.18	41.32	47.44			
224		2	50.52	50.60	44.42	44.39	44.45	50.58		
			50.50	50.64	44.38	44.35	44.50	50.62		
225		3	53.72	53.80	47.62	47.57	47.65	53.75		
			53.70	53.84	47.58	47.53	47.70	53.79		
226		4	56.89	56.98	50.80	50.74	50.83	56.93		
			56.88	57.02	50.75	50.70	50.87	56.97		
227		5	60.07	60.15	53.97	53.92	54.00	60.10		
			60.05	60.19	53.93	53.88	54.05	60.14		
228		6	63.24	63.33	57.15	57.09	57.18	63.28		
			63.20	63.37	57.10	57.05	57.22	63.32		
229		7	66.42	66.50	60.32	60.27	60.35	66.45		
			66.37	66.54	60.28	60.23	60.40	66.49		
230		8	69.59	69.68	63.50	63.44	63.53	69.63		
	69.55		69.72	63.45	63.40	63.57	69.67			
231	9	72.77	72.85	66.67	66.62	66.70	72.80			
		72.72	72.89	66.63	66.58	66.75	72.84			
232	10	75.94	76.03	69.85	69.79	69.88	75.98			
		75.90	76.07	69.80	69.75	69.92	76.02			
233	11	79.12	79.20	73.02	72.97	73.05	79.15			
		79.07	79.24	72.98	72.93	73.10	79.19			
234	12	82.29	82.38	76.20	76.12	76.20	82.30			
		82.25	82.42	76.15	76.08	76.25	82.34			
235	13	85.47	85.55	79.37	79.29	79.38	85.48			
		85.42	85.59	79.33	79.25	79.42	85.52			
236	14	88.64	88.73	82.55	82.47	82.55	88.65			
		88.60	88.77	82.50	82.43	82.60	88.69			
237	15	91.82	91.90	85.72	85.64	85.73	91.83			
		91.77	91.94	85.68	85.60	85.77	91.87			

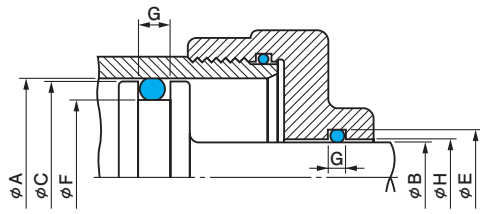

For Dynamic Applications

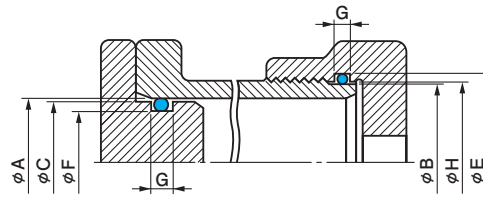

For Cylindrical Surface Static Applications

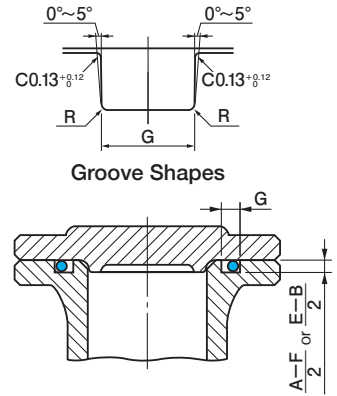

For Flat Face Static Applications

(Unit: mm)

MS28775 nominal dimensions	AN6227 nominal dimensions Old JIS W 1516 nominal number	AN6230 nominal dimensions Old JIS W 1517 nominal number	C	A	F	B	H	E	R	G No backup rings
238	Only use for static applications	16	94.99	95.08	88.90	88.82	88.90	95.00	0.63 0.26	4.78 5.02
			94.95	95.12	88.85	88.78	88.95	95.04		
239		17	98.17	98.25	92.07	91.99	92.08	98.18		
			98.12	98.29	92.03	91.95	92.12	98.22		
240		18	101.34	101.43	95.25	95.17	95.25	101.35		
			101.30	101.47	95.20	95.13	95.30	101.39		
241		19	104.52	104.60	98.42	98.34	98.43	104.53		
			104.47	104.64	98.38	98.30	98.47	104.57		
242		20	107.69	107.78	101.60	101.52	101.60	107.70		
			107.65	107.82	101.55	101.48	101.65	107.74		
243		21	110.87	110.95	104.77	104.69	104.78	110.88		
			110.82	110.99	104.73	104.65	104.82	110.92		
244	22	114.02	114.13	107.95	107.87	107.95	114.05			
		113.97	114.17	107.90	107.83	108.00	114.09			
245	23	117.19	117.30	111.12	111.04	111.13	117.23			
		117.15	117.34	111.08	111.00	111.17	117.27			
246	24	120.37	120.48	114.30	114.22	114.33	120.40			
		120.32	120.52	114.25	114.18	114.37	120.44			
247	25	123.54	123.65	117.47	117.39	117.50	123.58			
		123.50	123.69	117.43	117.35	117.55	123.62			
325	28	0.88 0.51	47.34	47.43	37.97	38.04	38.10	47.50	7.14 7.39	
			47.32	47.47	37.93	38.00	38.15	47.54		
326	29		50.52	50.60	41.14	41.22	41.28	50.68		
			50.50	50.64	41.10	41.18	41.32	50.72		
327	30		53.72	53.80	44.34	44.39	44.45	53.85		
			53.70	53.84	44.30	44.35	44.50	53.89		
328	31		56.89	56.98	47.52	47.57	47.65	57.03		
			56.88	57.02	47.48	47.53	47.70	57.07		
329	32		60.07	60.15	50.69	50.74	50.83	60.20		
			60.05	60.19	50.65	50.70	50.87	60.24		
330	33		63.24	63.33	53.87	53.92	54.00	63.38		
			63.20	63.37	53.83	53.88	54.05	63.42		
331	34		66.42	66.50	57.04	57.09	57.18	66.55		
			66.37	66.54	57.00	57.05	57.22	66.59		
332	35		69.59	69.68	60.22	60.27	60.35	69.73		
			69.55	69.72	60.18	60.23	60.40	69.77		
333	36		72.77	72.85	63.39	63.44	63.53	72.90		
			72.72	72.89	63.35	63.40	63.57	72.94		
334	37		75.94	76.03	66.57	66.62	66.70	76.08		
			75.90	76.07	66.53	66.58	66.75	76.12		
335	38		79.12	79.20	69.74	69.79	69.88	79.25		
			79.07	79.24	69.70	69.75	69.92	79.29		
336	39		82.29	82.38	72.92	72.97	73.05	82.43		
			82.25	82.42	72.88	72.93	73.10	82.47		
337	40	85.47	85.55	76.09	76.12	76.20	85.58			
		85.42	85.59	76.05	76.08	76.25	85.62			
338	41	88.64	88.73	79.27	79.29	79.38	88.75			
		88.60	88.77	79.23	79.25	79.42	88.79			

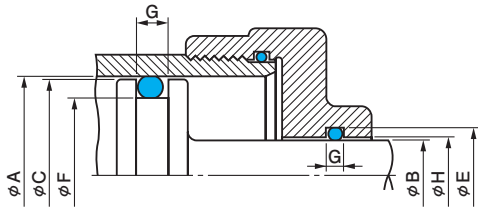
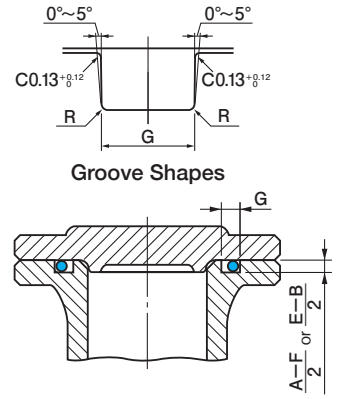

For Dynamic Applications

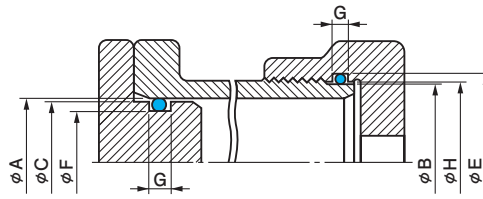

For Cylindrical Surface Static Applications

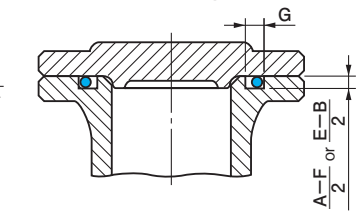

For Flat Face Static Applications

(Unit: mm)

MS28775 nominal dimensions	AN6227 nominal dimensions Old JIS W 1516 nominal number	AN6230 nominal dimensions Old JIS W 1517 nominal number	C	A	F	B	H	E	R	G No backup rings
339	42		91.82	91.90	82.44	82.47	82.55	91.93	0.88 0.51	7.14 7.39
			91.77	91.94	82.40	82.43	82.60	91.97		
340	43		94.99	95.08	85.62	85.64	85.73	95.10		
			94.95	95.12	85.58	85.60	85.77	95.14		
341	44		98.17	98.25	88.79	88.82	88.90	98.28		
			98.12	98.29	88.75	88.78	88.95	98.32		
342	45		101.34	101.43	91.97	91.99	92.08	101.45		
			101.30	101.47	91.93	91.95	92.12	101.49		
343	46		104.52	104.60	95.14	95.17	95.25	104.63		
			104.47	104.64	95.10	95.13	95.30	104.67		
344	47		107.69	107.78	98.32	98.34	98.43	107.80		
			107.65	107.82	98.28	98.30	98.47	107.84		
345	48		110.87	110.95	101.49	101.52	101.60	110.98		
			110.82	110.99	101.45	101.48	101.65	111.02		
346	49		114.02	114.13	104.67	104.69	104.78	114.15		
			113.97	114.17	104.63	104.65	104.82	114.19		
347	50		117.19	117.30	107.84	107.87	107.95	117.33		
			117.15	117.34	107.80	107.83	108.00	117.37		
348	51		120.37	120.48	111.02	111.04	111.13	120.50		
			120.32	120.52	110.98	111.00	111.17	120.54		
349	52		123.54	123.65	114.19	114.22	114.30	123.68		
			123.50	123.69	114.15	114.18	114.35	123.72		
425	88		126.23	126.34	114.22	114.22	114.33	126.34		
			126.19	126.41	114.15	114.15	114.37	126.41		
426	53		129.41	129.52	117.39	117.39	117.50	129.52		
			129.37	129.59	117.33	117.33	117.55	129.59		
427	54		132.58	132.69	120.57	120.57	120.68	132.69		
			132.54	132.76	120.50	120.50	120.72	132.76		
428	55		135.76	135.87	123.74	123.74	123.85	135.87		
			135.72	135.94	123.68	123.68	123.90	135.94		
429	56		138.93	139.04	126.92	126.92	127.03	139.04		
			138.89	139.11	126.85	126.85	127.07	139.11		
430	57		142.11	142.22	130.09	130.09	130.20	142.22		
			142.07	142.29	130.03	130.03	130.25	142.29		
431	58		145.28	145.39	133.27	133.27	133.38	145.39		
			145.24	145.46	133.20	133.20	133.42	145.46		
432	59		148.46	148.57	136.44	136.44	136.55	148.57		
			148.42	148.64	136.38	136.38	136.60	148.64		
433	60		151.63	151.74	139.62	139.62	139.73	151.74		
			151.59	151.81	139.55	139.55	139.77	151.81		
434	61		154.81	154.92	142.79	142.79	142.90	154.92		
			154.77	154.99	142.73	142.73	142.95	154.99		
435	62		157.98	158.09	145.97	145.97	146.08	158.09		
			157.94	158.16	145.90	145.90	146.12	158.16		
436	63		161.16	161.27	149.14	149.14	149.25	161.27		
			161.12	161.34	149.08	149.08	149.30	161.34		
437	64		164.33	164.44	152.32	152.32	152.43*	164.44		
			164.29	164.51	152.25	152.25	152.47*	164.51		

*Values determined by NOK.

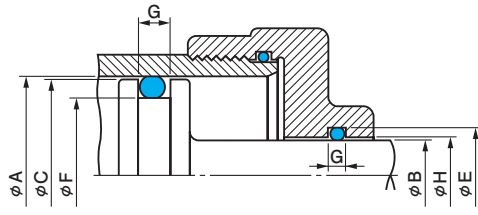
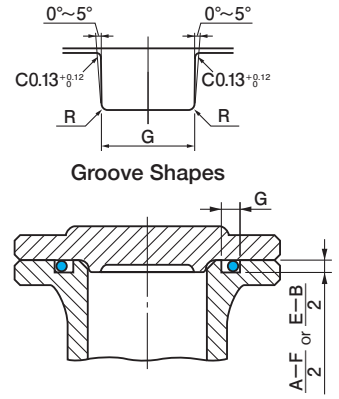

For Dynamic Applications

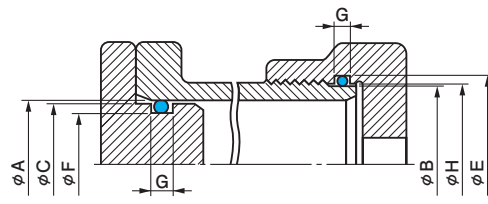

For Cylindrical Surface Static Applications

For Flat Face Static Applications

(Unit: mm)

MS28775 nominal dimensions	AN6227 nominal dimensions Old JIS W 1516 nominal number	AN6230 nominal dimensions Old JIS W 1517 nominal number	C	A	F	B	H	E	R	G
438	65		170.68	170.79	158.67	158.67	158.78	170.79	0.88 0.51	9.53 9.77
			170.64	170.86	158.60	158.60	158.82	170.86		
439	66		177.03	177.14	165.02	165.02	165.13	177.14		
			176.99	177.21	164.95	164.95	165.20	177.21		
440	67		183.38	183.49	171.37	171.37	171.48	183.49		
			183.34	183.56	171.30	171.30	171.55	183.56		
441	68		189.73	189.84	177.72	177.72	177.83	189.84		
			189.69	189.91	177.65	177.65	177.90	189.91		
442	69		196.08	196.19	184.07	184.07	184.18	196.19		
			196.04	196.26	184.00	184.00	184.25	196.26		
443	70		202.43	202.54	190.42	190.42	190.53	202.54		
			202.39	202.61	190.35	190.35	190.60	202.61		
444	71		208.78	208.89	196.77	196.77	196.88	208.89		
			208.74	208.96	196.70	196.70	196.95	208.96		
445	72		215.13	215.24	203.12	203.12	203.23	215.24		
			215.09	215.31	203.05	203.05	203.30	215.31		
446	73		227.83	227.94	215.82	215.82	215.93	227.94		
			227.77	228.01	215.75	215.75	216.00	228.01		
447	74		240.53	240.64	228.52	228.52	228.63	240.64		
			240.47	240.74	228.45	228.45	228.70	240.74		
448	75		253.23	253.34	241.22	241.22	241.33	253.34		
			253.17	253.44	241.15	241.15	241.40	253.44		
449	76		265.93	266.04	253.92	253.92	254.03	266.04		
			265.87	266.14	253.85	253.85	254.10	266.14		
450	77		278.63	278.74	266.62	266.62	266.73	278.74		
			278.57	278.84	266.55	266.55	266.80	278.84		
451	78		291.33	291.44	279.32	279.32	279.43	291.44		
			291.27	291.54	279.25	279.25	279.50	291.54		
452	79		304.03	304.14	292.02	292.02	292.13	304.14		
			303.97	304.24	291.95	291.95	292.20	304.24		
453	80		316.73	316.84	304.72	304.72	304.83	316.84		
			316.67	316.94	304.65	304.65	304.90	316.94		
454	81		329.43	329.54	317.42	317.42	317.53	329.54		
			329.37	329.64	317.35	317.35	317.60	329.64		
455	82		342.13	342.24	330.12	330.12	330.23	342.24		
			342.07	342.34	330.05	330.05	330.30	342.34		
456	83		354.83	354.94	342.82	342.82	342.93	354.94		
			354.77	355.04	342.75	342.75	343.00	355.04		
457	84		367.53	367.64	355.52	355.52	355.63	367.64		
			367.47	367.74	355.45	355.45	355.70	367.74		
458	85		380.23	380.34	368.22	368.22	368.33	380.34		
			380.17	380.44	368.15	368.15	368.40	380.44		
459	86		392.93	393.04	380.92	380.92	381.03	393.04		
			392.87	393.14	380.85	380.85	381.10	393.14		
460	87		405.63	405.74	393.62	393.62	393.73	405.74		
			405.57	405.84	393.55	393.55	393.80	405.84		

22. O-Ring Dimension Quick Chart

(1) Relationship Between O-Ring Inside Diameter and Thickness

The relationship between inside diameter and thickness for NOK O-rings is shown here.

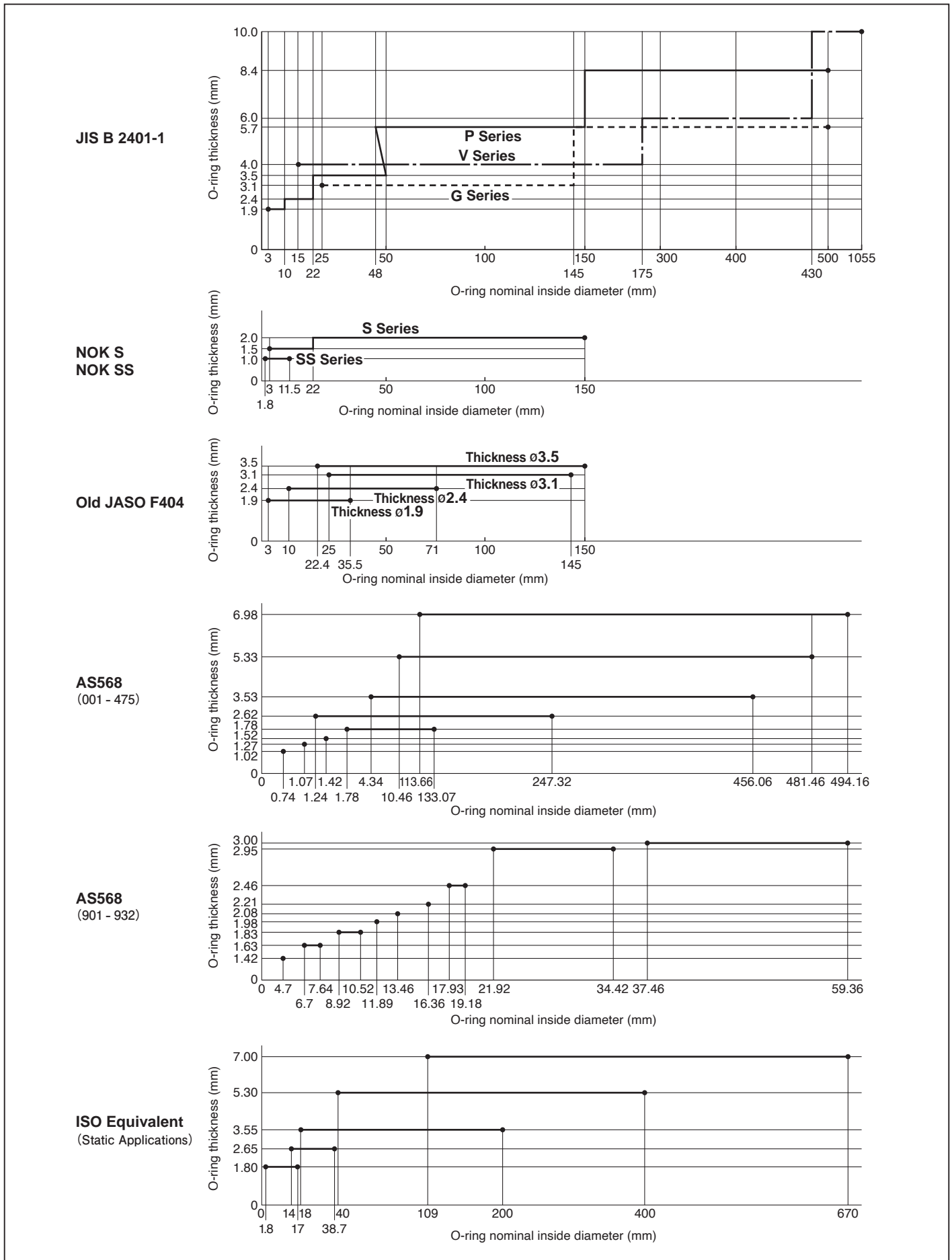

(2) Simplified Dimension Table (list sorted by inside diameter)

Inside diameter d _o	Outside diameter D	Thickness W	Dimension code	Applicable standard	Page listed	Inside diameter d _o	Outside diameter D	Thickness W	Dimension code	Applicable standard	Page listed
0.74	2.78	1.02	CO 8424	AS568	38	7.80	11.60	1.90	CO 00005	P	22
1.07	3.61	1.27	CO 3387	AS568	38	8.00	10.00	1.00	CO 7044	SS	36
1.24	6.48	2.62	CO 8485	AS568	39	8.00	11.60	1.80	CO 7217	ISO	54
1.42	4.46	1.52	CO 3388	AS568	38	8.50	11.50	1.50	CO 0506	S	34
1.78	5.34	1.78	CO 5146	AS568	38	8.50	10.50	1.00	CO 4945	SS	36
1.80	3.80	1.00	CO 3325	SS	36	8.50	12.10	1.80	CO 7218	ISO	54
1.80	5.40	1.80	CO 7200	ISO	54	8.75	12.35	1.80	CO 7219	ISO	54
2.00	4.00	1.00	CO 2956	SS	36	8.80	12.60	1.90	CO 00006	P	22
2.00	5.60	1.80	CO 7201	ISO	54	8.92	12.58	1.83	CO 3597	AS568	45
2.06	7.30	2.62	CO 8464	AS568	39	9.00	11.00	1.00	CO 7949	SS	36
2.24	5.84	1.80	CO 7202	ISO	54	9.00	12.60	1.80	CO 1061	ISO	54
2.50	5.50	1.50	CO 0500	S	34	9.12	16.18	3.53	CO 7048	AS568	40
2.50	4.50	1.00	CO 3700	SS	36	9.19	14.43	2.62	CO 0406	AS568	39
2.50	6.10	1.80	CO 7203	ISO	54	9.25	12.81	1.78	CO 0407	AS568	38
2.57	6.13	1.78	CO 3052	AS568	38	9.50	12.50	1.50	CO 0507	S	34
2.80	6.60	1.90	CO 00000	P	22	9.50	11.50	1.00	CO 8847	SS	36
2.80	6.40	1.80	CO 7204	ISO	54	9.50	13.10	1.80	CO 7221	ISO	54
2.84	8.08	2.62	CO 8465	AS568	39	9.80	13.60	1.90	CO 00007	P	22
2.90	6.46	1.78	CO 0400	AS568	38	9.80	14.60	2.40	CO 00008	P	22
3.00	5.00	1.00	CO 3835	SS	36	10.00	12.00	1.00	CO 8848	SS	36
3.15	6.75	1.80	CO 7205	ISO	54	10.00	13.60	1.80	CO 7222	ISO	54
3.50	6.50	1.50	CO 0501	S	34	10.46	21.12	5.33	CO 8486	AS568	42
3.50	5.50	1.00	DO 1127	SS	36	10.50	12.50	1.00	CO 8849	SS	36
3.55	7.15	1.80	CO 7206	ISO	54	10.52	14.18	1.83	CO 1087	AS568	45
3.63	8.87	2.62	CO 8466	AS568	39	10.60	14.20	1.80	CO 7223	ISO	54
3.68	7.24	1.78	CO 0401	AS568	38	10.69	17.75	3.53	CO 7049	AS568	40
3.75	7.35	1.80	CO 7207	ISO	54	10.70	13.70	1.50	CO 0508	S	34
3.80	7.60	1.90	CO 00001	P	22	10.77	16.01	2.62	CO 0408	AS568	39
4.00	6.00	1.00	CO 7820	SS	36	10.80	15.60	2.40	CO 00009	P	22
4.00	7.60	1.80	CO 7208	ISO	54	10.82	14.38	1.78	CO 3174	AS568	38
4.34	11.40	3.53	CO 8471	AS568	40	11.00	15.80	2.40	CO 00010	P	22
4.42	9.66	2.62	CO 8467	AS568	39	11.00	13.00	1.00	CO 5952	SS	36
4.47	8.03	1.78	CO 0402	AS568	38	11.00	14.80	1.90	CO 0600	JASO	46
4.50	7.50	1.50	CO 0502	S	34	11.20	14.80	1.80	CO 7224	ISO	54
4.50	6.50	1.00	CO 3729	SS	36	11.50	14.50	1.50	CO 0509	S	34
4.50	8.10	1.80	CO 1012	ISO	54	11.50	13.50	1.00	CO 8850	SS	36
4.70	7.54	1.42	CO 5480	AS568	45	11.80	16.60	2.40	CO 00011	P	22
4.80	8.60	1.90	CO 00002	P	22	11.80	15.40	1.80	CO 1109	ISO	54
4.87	8.47	1.80	CO 7209	ISO	54	11.89	15.85	1.98	CO 3604	AS568	45
5.00	7.00	1.00	CO 3370	SS	36	12.00	15.00	1.50	CO 0510	S	34
5.00	8.60	1.80	CO 7210	ISO	54	12.06	22.72	5.33	CO 8487	AS568	42
5.15	8.75	1.80	CO 7211	ISO	54	12.29	19.35	3.53	CO 8460	AS568	40
5.23	10.47	2.62	CO 6006	AS568	39	12.30	17.10	2.40	CO 00012	P	22
5.28	8.84	1.78	CO 0403	AS568	38	12.30	16.10	1.90	CO 0601	JASO	46
5.30	8.90	1.80	CO 7212	ISO	54	12.37	17.61	2.62	CO 0409	AS568	39
5.50	8.50	1.50	CO 0503	S	34	12.42	15.98	1.78	CO 1119	AS568	38
5.50	7.50	1.00	CO 3765	SS	36	12.50	16.10	1.80	CO 7225	ISO	54
5.60	9.20	1.80	CO 6868	ISO	54	13.00	16.80	1.90	CO 0602	JASO	46
5.80	9.60	1.90	CO 00003	P	22	13.00	17.80	2.40	CO 0603	JASO	48
5.94	13.00	3.53	CO 8472	AS568	40	13.20	16.80	1.80	CO 7226	ISO	54
6.00	8.00	1.00	CO 3216	SS	36	13.46	17.62	2.08	CO 8804	AS568	45
6.00	9.60	1.80	CO 3026	ISO	54	13.50	16.50	1.50	CO 0511	S	34
6.02	11.26	2.62	CO 8468	AS568	39	13.64	24.30	5.33	CO 8488	AS568	42
6.07	9.63	1.78	CO 0404	AS568	38	13.80	18.60	2.40	CO 00013	P	22
6.07	9.33	1.63	CO 3091	AS568	45	13.80	17.60	1.90	CO 0604	JASO	46
6.30	9.90	1.80	CO 7213	ISO	54	13.87	20.93	3.53	CO 7059	AS568	40
6.50	9.50	1.50	CO 0504	S	34	13.94	19.18	2.62	CO 0410	AS568	39
6.50	8.50	1.00	CO 8846	SS	36	14.00	17.56	1.78	CO 1140	AS568	38
6.70	10.30	1.80	CO 7038	ISO	54	14.00	17.60	1.80	CO 3441	ISO	54
6.80	10.60	1.90	CO 00004	P	22	14.00	19.30	2.65	CO 7228	ISO	54
6.90	10.50	1.80	CO 7214	ISO	54	14.50	17.50	1.50	CO 0512	S	34
7.00	9.00	1.00	CO 5497	SS	36	14.50	22.50	4.00	CO 00300	V	37
7.10	10.70	1.80	CO 7215	ISO	54	14.80	19.60	2.40	CO 00014	P	22
7.50	10.50	1.50	CO 0505	S	34	14.80	18.60	1.90	CO 0605	JASO	46
7.50	9.50	1.00	CO 4275	SS	36	15.00	18.60	1.80	CO 6822	ISO	54
7.50	11.10	1.80	CO 7216	ISO	54	15.00	20.30	2.65	CO 7229	ISO	54
7.52	14.58	3.53	CO 4527	AS568	40	15.24	25.90	5.33	CO 4082	AS568	42
7.59	12.83	2.62	CO 3084	AS568	39	15.47	22.53	3.53	CO 5250	AS568	40
7.64	10.90	1.63	CO 7600	AS568	45	15.50	18.50	1.50	CO 0513	S	34
7.65	11.21	1.78	CO 0405	AS568	38	15.54	20.78	2.62	CO 0411	AS568	39

*In the table above, the following indications are used:

•Former JASO → JASO •ISO equivalent → ISO

Even for O-rings for the dimensions given in this table, it may be necessary to prepare new tooling depending on the material used. For more details, please refer to the page on which the O-ring is listed.

Inside diameter d _o	Outside diameter D	Thickness W	Dimension code	Applicable standard	Page listed
15.60	19.16	1.78	CO 3035	AS568	38
15.80	20.60	2.40	CO 00015	P	22
15.80	19.60	1.90	CO 0606	JASO	46
16.00	19.60	1.80	CO 6861	ISO	54
16.00	21.30	2.65	CO 7230	ISO	54
16.36	20.78	2.21	CO 1165	AS568	45
16.80	21.60	2.40	CO 0608	JASO	48
16.80	20.60	1.90	CO 0607	JASO	46
16.81	27.47	5.33	CO 8480	AS568	42
17.00	20.60	1.80	CO 7227	ISO	54
17.00	22.30	2.65	CO 7231	ISO	54
17.04	24.10	3.53	CO 8461	AS568	40
17.12	22.36	2.62	CO 0412	AS568	39
17.17	20.73	1.78	CO 1179	AS568	38
17.50	20.50	1.50	CO 0514	S	34
17.80	22.60	2.40	CO 00016	P	22
17.80	21.60	1.90	CO 0609	JASO	46
17.93	22.85	2.46	CO 8805	AS568	45
18.00	23.30	2.65	CO 7232	ISO	54
18.00	25.10	3.55	CO 7251	ISO	54
18.42	29.08	5.33	CO 8481	AS568	42
18.64	25.70	3.53	CO 0413	AS568	40
18.72	23.96	2.62	CO 0414	AS568	39
18.77	22.33	1.78	CO 1203	AS568	38
18.80	22.60	1.90	CO 0610	JASO	46
18.80	23.60	2.40	CO 0611	JASO	48
19.00	24.30	2.65	CO 7233	ISO	54
19.00	26.10	3.55	CO 7252	ISO	54
19.18	24.10	2.46	CO 1206	AS568	45
19.50	22.50	1.50	CO 0515	S	34
19.80	24.60	2.40	CO 00017	P	22
19.80	23.60	1.90	CO 0612	JASO	46
19.99	30.65	5.33	CO 7777	AS568	42
20.00	25.30	2.65	CO 7234	ISO	54
20.00	27.10	3.55	CO 7253	ISO	54
20.22	27.28	3.53	CO 0415	AS568	40
20.29	25.53	2.62	CO 4370	AS568	39
20.35	23.91	1.78	CO 1225	AS568	38
20.80	25.60	2.40	CO 00018	P	22
21.00	24.80	1.90	CO 0613	JASO	46
21.20	26.50	2.65	CO 7235	ISO	54
21.20	28.30	3.55	CO 7254	ISO	54
21.50	24.50	1.50	CO 0516	S	34
21.59	32.25	5.33	CO 8482	AS568	42
21.70	28.70	3.50	CO 00019	P	22
21.80	26.60	2.40	CO 00020	P	22
21.82	28.88	3.53	CO 0416	AS568	40
21.89	27.13	2.62	CO 1240	AS568	39
21.90	25.90	2.00	CO 0517	S	34
21.92	27.82	2.95	CO 8234	AS568	45
21.95	25.51	1.78	CO 1241	AS568	38
22.10	25.90	1.90	CO 0614	JASO	46
22.10	29.10	3.50	CO 00021	P	22
22.10	26.90	2.40	CO 0615	JASO	48
22.40	27.70	2.65	CO 7236	ISO	54
22.40	29.50	3.55	CO 7255	ISO	54
23.16	33.82	5.33	CO 6064	AS568	42
23.30	27.10	1.90	CO 0616	JASO	46
23.30	28.10	2.40	CO 0617	JASO	48
23.39	30.45	3.53	CO 0417	AS568	40
23.46	28.70	2.62	CO 6065	AS568	39
23.47	29.37	2.95	CO 1253	AS568	45
23.50	27.50	2.00	CO 0518	S	34
23.50	31.50	4.00	CO 00301	V	37
23.52	27.08	1.78	CO 3037	AS568	38
23.60	28.90	2.65	CO 7237	ISO	54
23.60	30.70	3.55	CO 7256	ISO	54
23.70	30.70	3.50	CO 00022	P	22
24.40	30.60	3.10	CO 00200	G	30
24.50	28.50	2.00	CO 0519	S	34

Inside diameter d _o	Outside diameter D	Thickness W	Dimension code	Applicable standard	Page listed
24.70	31.70	3.50	CO 00023	P	22
24.70	29.50	2.40	CO 0619	JASO	48
24.70	28.50	1.90	CO 0618	JASO	46
24.76	35.42	5.33	CO 3025	AS568	42
24.99	32.05	3.53	CO 0418	AS568	41
25.00	30.30	2.65	CO 7238	ISO	54
25.00	32.10	3.55	CO 7257	ISO	54
25.04	30.94	2.95	CO 8806	AS568	45
25.07	30.31	2.62	CO 3805	AS568	39
25.12	28.68	1.78	CO 4368	AS568	38
25.20	32.20	3.50	CO 00024	P	22
25.50	29.50	2.00	CO 0520	S	34
25.70	32.70	3.50	CO 00025	P	22
25.80	31.10	2.65	CO 7239	ISO	54
25.80	32.90	3.55	CO 7258	ISO	54
26.20	31.00	2.40	CO 0621	JASO	48
26.20	30.00	1.90	CO 0620	JASO	46
26.34	37.00	5.33	CO 8483	AS568	42
26.50	31.80	2.65	CO 7240	ISO	54
26.50	33.60	3.55	CO 7259	ISO	54
26.57	33.63	3.53	CO 0419	AS568	41
26.59	32.49	2.95	CO 2998	AS568	45
26.64	31.88	2.62	CO 3601	AS568	39
26.70	30.26	1.78	CO 3173	AS568	38
27.50	31.50	2.00	CO 0521	S	34
27.70	34.70	3.50	CO 00026	P	22
27.70	31.50	1.90	CO 0622	JASO	46
27.70	32.50	2.40	CO 0623	JASO	48
27.94	38.60	5.33	CO 4337	AS568	42
28.00	33.30	2.65	CO 7241	ISO	54
28.00	35.10	3.55	CO 7260	ISO	54
28.17	35.23	3.53	CO 0420	AS568	41
28.24	33.48	2.62	CO 4128	AS568	39
28.30	31.86	1.78	CO 1302	AS568	38
28.50	32.50	2.00	CO 0522	S	34
28.70	35.70	3.50	CO 00027	P	22
29.20	36.20	3.50	CO 00028	P	22
29.40	35.60	3.10	CO 00201	G	30
29.50	33.50	2.00	CO 0523	S	34
29.51	40.17	5.33	CO 7778	AS568	42
29.70	36.70	3.50	CO 00029	P	22
29.70	33.50	1.90	CO 0624	JASO	46
29.70	34.50	2.40	CO 0625	JASO	48
29.74	36.80	3.53	CO 0421	AS568	41
29.74	35.64	2.95	CO 1315	AS568	45
29.82	35.06	2.62	CO 3105	AS568	39
29.87	33.43	1.78	CO 3636	AS568	38
30.00	35.30	2.65	CO 7242	ISO	54
30.00	37.10	3.55	CO 7261	ISO	54
30.70	37.70	3.50	CO 00030	P	22
31.00	35.00	2.00	CO 0524	S	34
31.12	41.78	5.33	CO 4081	AS568	42
31.20	36.00	2.40	CO 0627	JASO	48
31.20	35.00	1.90	CO 0626	JASO	46
31.20	38.20	3.50	CO 00031	P	22
31.34	38.40	3.53	CO 0422	AS568	41
31.42	36.66	2.62	CO 3112	AS568	39
31.47	35.03	1.78	CO 3093	AS568	38
31.50	35.50	2.00	CO 0525	S	34
31.50	36.80	2.65	CO 7243	ISO	54
31.50	38.60	3.55	CO 7262	ISO	54
31.70	38.70	3.50	CO 00032	P	22
32.50	37.80	2.65	CO 7244	ISO	54
32.50	39.60	3.55	CO 7263	ISO	54
32.69	43.35	5.33	CO 8484	AS568	42
32.92	39.98	3.53	CO 0423	AS568	41
32.99	38.23	2.62	CO 3230	AS568	39
33.05	36.61	1.78	CO 7771	AS568	38
33.20	38.00	2.40	CO 0629	JASO	48
33.20	37.00	1.90	CO 0628	JASO	46

*In the table above, the following indications are used:
 •Former JASO → JASO •ISO equivalent → ISO

Inside diameter d _o	Outside diameter D	Thickness W	Dimension code	Applicable standard	Page listed
33.50	37.50	2.00	CO 0526	S	34
33.50	41.50	4.00	CO 00302	V	37
33.50	38.80	2.65	CO 7245	ISO	54
33.50	40.60	3.55	CO 7264	ISO	54
33.70	40.70	3.50	CO 00033	P	22
34.29	44.95	5.33	CO 4070	AS568	42
34.40	40.60	3.10	CO 00202	G	30
34.42	40.32	2.95	CO 8807	AS568	45
34.50	38.50	2.00	CO 0527	S	34
34.50	39.80	2.65	CO 7246	ISO	54
34.50	41.60	3.55	CO 7265	ISO	54
34.52	41.58	3.53	CO 0424	AS568	41
34.59	39.83	2.62	CO 3449	AS568	39
34.65	38.21	1.78	CO 3092	AS568	38
34.70	41.70	3.50	CO 00034	P	22
35.00	39.00	2.00	CO 0528	S	34
35.20	42.20	3.50	CO 00035	P	22
35.20	39.00	1.90	CO 0630	JASO	46
35.20	40.00	2.40	CO 0631	JASO	48
35.50	39.50	2.00	CO 0529	S	34
35.50	40.80	2.65	CO 7247	ISO	54
35.50	42.60	3.55	CO 7266	ISO	54
35.70	42.70	3.50	CO 00036	P	22
36.09	43.15	3.53	CO 0425	AS568	41
36.17	41.41	2.62	CO 1367	AS568	39
36.50	41.80	2.65	CO 7248	ISO	54
36.50	43.60	3.55	CO 7267	ISO	54
37.20	42.00	2.40	CO 0632	JASO	48
37.46	48.12	5.33	CO 0427	AS568	42
37.46	43.46	3.00	CO 3640	AS568	45
37.50	41.50	2.00	CO 0530	S	34
37.50	42.80	2.65	CO 7249	ISO	54
37.50	44.60	3.55	CO 7268	ISO	54
37.69	44.75	3.53	CO 0426	AS568	41
37.70	44.70	3.50	CO 00037	P	22
37.77	43.01	2.62	CO 1380	AS568	39
37.82	41.38	1.78	CO 6134	AS568	38
38.50	42.50	2.00	CO 0531	S	34
38.70	45.70	3.50	CO 00038	P	22
38.70	44.00	2.65	CO 7250	ISO	54
38.70	45.80	3.55	CO 7269	ISO	54
39.34	44.58	2.62	CO 3851	AS568	39
39.40	45.60	3.10	CO 00203	G	30
39.50	43.50	2.00	CO 0532	S	34
39.50	47.50	4.00	CO 00303	V	37
39.70	46.70	3.50	CO 00039	P	22
39.70	44.50	2.40	CO 0633	JASO	48
40.00	47.10	3.55	CO 7270	ISO	54
40.00	50.60	5.30	CO 7327	ISO	55
40.64	51.30	5.33	CO 0428	AS568	42
40.70	47.70	3.50	CO 00040	P	22
40.87	47.93	3.53	CO 0350	AS568	41
40.94	46.18	2.62	CO 4408	AS568	39
41.00	44.56	1.78	CO 3191	AS568	38
41.20	48.30	3.55	CO 7271	ISO	54
41.20	51.80	5.30	CO 7328	ISO	55
41.50	45.50	2.00	CO 0533	S	34
41.70	48.70	3.50	CO 00041	P	22
42.20	47.00	2.40	CO 0634	JASO	48
42.50	49.60	3.55	CO 7272	ISO	54
42.50	53.10	5.30	CO 7329	ISO	55
42.52	47.76	2.62	CO 6151	AS568	39
43.50	47.50	2.00	CO 0534	S	35
43.69	49.69	3.00	CO 3706	AS568	45
43.70	50.70	3.50	CO 00042	P	22
43.70	50.80	3.55	CO 7273	ISO	54
43.70	54.30	5.30	CO 7330	ISO	55
43.82	54.48	5.33	CO 0429	AS568	42
44.04	51.10	3.53	CO 0351	AS568	41
44.12	49.36	2.62	CO 6155	AS568	39

Inside diameter d _o	Outside diameter D	Thickness W	Dimension code	Applicable standard	Page listed
44.17	47.73	1.78	CO 5191	AS568	38
44.40	50.60	3.10	CO 00204	G	30
44.50	48.50	2.00	CO 0535	S	35
44.70	49.50	2.40	CO 0635	JASO	48
44.70	51.70	3.50	CO 00043	P	22
45.00	52.10	3.55	CO 7274	ISO	54
45.00	55.60	5.30	CO 4643	ISO	55
45.50	49.50	2.00	CO 0536	S	35
45.69	50.93	2.62	CO 3152	AS568	39
45.70	52.70	3.50	CO 00044	P	22
46.20	53.30	3.55	CO 7275	ISO	54
46.20	56.80	5.30	CO 7331	ISO	55
46.99	57.65	5.33	CO 0430	AS568	42
47.20	52.00	2.40	CO 0636	JASO	48
47.22	54.28	3.53	CO 0352	AS568	41
47.29	52.53	2.62	CO 1433	AS568	39
47.35	50.91	1.78	CO 3235	AS568	38
47.50	51.50	2.00	CO 0537	S	35
47.50	54.60	3.55	CO 7276	ISO	54
47.50	58.10	5.30	CO 7332	ISO	55
47.60	59.00	5.70	CO 00045	P	24
47.70	54.70	3.50	CO 00046	P	22
48.70	55.70	3.50	CO 00047	P	24
48.70	55.80	3.55	CO 7277	ISO	54
48.70	59.30	5.30	CO 7333	ISO	55
48.90	54.14	2.62	CO 8469	AS568	39
49.40	55.60	3.10	CO 00205	G	30
49.50	53.50	2.00	CO 0538	S	35
49.60	61.00	5.70	CO 00048	P	24
49.70	56.70	3.50	CO 00049	P	24
49.70	54.50	2.40	CO 0637	JASO	48
50.00	57.10	3.55	CO 7278	ISO	54
50.00	60.60	5.30	CO 7334	ISO	55
50.16	60.82	5.33	CO 0431	AS568	42
50.39	57.45	3.53	CO 0353	AS568	41
50.47	55.71	2.62	CO 4330	AS568	39
50.52	54.08	1.78	CO 5346	AS568	38
51.50	58.60	3.55	CO 7279	ISO	54
51.50	62.10	5.30	CO 7335	ISO	55
51.60	63.00	5.70	CO 00050	P	24
52.07	57.31	2.62	CO 1461	AS568	39
52.50	56.50	2.00	CO 0539	S	35
52.60	59.60	3.50	CO 0639	JASO	52
52.60	64.00	5.70	CO 00051	P	24
52.60	57.40	2.40	CO 0638	JASO	48
53.00	60.10	3.55	CO 7280	ISO	54
53.00	63.60	5.30	CO 7336	ISO	55
53.09	59.09	3.00	CO 8808	AS568	45
53.34	64.00	5.33	CO 0432	AS568	42
53.57	60.63	3.53	CO 0354	AS568	41
53.64	58.88	2.62	CO 3707	AS568	39
53.70	57.26	1.78	CO 1467	AS568	38
54.40	60.60	3.10	CO 00206	G	30
54.50	58.50	2.00	CO 0540	S	35
54.50	62.50	4.00	CO 00304	V	37
54.50	61.60	3.55	CO 7281	ISO	54
54.50	65.10	5.30	CO 7337	ISO	55
54.60	66.00	5.70	CO 00052	P	24
55.24	60.48	2.62	CO 6189	AS568	39
55.50	59.50	2.00	CO 0541	S	35
55.60	60.40	2.40	CO 0640	JASO	48
55.60	67.00	5.70	CO 00053	P	24
55.60	62.60	3.50	CO 0641	JASO	52
56.00	63.10	3.55	CO 7282	ISO	54
56.00	66.60	5.30	CO 7338	ISO	55
56.52	67.18	5.33	CO 0433	AS568	42
56.74	63.80	3.53	CO 0355	AS568	41
56.82	62.06	2.62	CO 3107	AS568	39
56.87	60.43	1.78	CO 7772	AS568	38
57.60	69.00	5.70	CO 00054	P	24

*In the table above, the following indications are used:

•Former JASO → JASO •ISO equivalent → ISO

Even for O-rings for the dimensions given in this table, it may be necessary to prepare new tooling depending on the material used. For more details, please refer to the page on which the O-ring is listed.

Inside diameter d _o	Outside diameter D	Thickness W	Dimension code	Applicable standard	Page listed
58.00	65.10	3.55	CO 7283	ISO	54
58.00	68.60	5.30	CO 7339	ISO	55
58.42	63.66	2.62	CO 6202	AS568	39
59.36	65.36	3.00	CO 8809	AS568	45
59.40	65.60	3.10	CO 00207	G	30
59.50	63.50	2.00	CO 0542	S	35
59.60	71.00	5.70	CO 00055	P	24
59.60	64.40	2.40	CO 0642	JASO	48
59.60	66.60	3.50	CO 0643	JASO	52
59.69	70.35	5.33	CO 0434	AS568	43
59.92	66.98	3.53	CO 0356	AS568	41
59.99	65.23	2.62	CO 6210	AS568	39
60.00	67.10	3.55	CO 7284	ISO	54
60.00	70.60	5.30	CO 7340	ISO	55
60.05	63.61	1.78	CO 4714	AS568	38
61.50	68.60	3.55	CO 7285	ISO	54
61.50	72.10	5.30	CO 7341	ISO	55
61.59	66.83	2.62	CO 7872	AS568	39
61.60	73.00	5.70	CO 00056	P	24
62.50	66.50	2.00	CO 0543	S	35
62.60	67.40	2.40	CO 0644	JASO	48
62.60	74.00	5.70	CO 00057	P	24
62.60	69.60	3.50	CO 0645	JASO	52
62.86	73.52	5.33	CO 0435	AS568	43
63.00	70.10	3.55	CO 7286	ISO	54
63.00	73.60	5.30	CO 7342	ISO	55
63.09	70.15	3.53	CO 0357	AS568	41
63.17	68.41	2.62	CO 4253	AS568	39
63.22	66.78	1.78	CO 8462	AS568	38
64.40	70.60	3.10	CO 00208	G	30
64.50	68.50	2.00	CO 0544	S	35
64.60	76.00	5.70	CO 00058	P	24
64.77	70.01	2.62	CO 1518	AS568	40
65.00	72.10	3.55	CO 7287	ISO	54
65.00	75.60	5.30	CO 7343	ISO	55
66.04	76.70	5.33	CO 0436	AS568	43
66.27	73.33	3.53	CO 0358	AS568	41
66.34	71.58	2.62	CO 3148	AS568	40
66.40	69.96	1.78	CO 8231	AS568	38
66.50	70.50	2.00	CO 0545	S	35
66.60	71.40	2.40	CO 0646	JASO	48
66.60	78.00	5.70	CO 00059	P	24
66.60	73.60	3.50	CO 0647	JASO	52
67.00	74.10	3.55	CO 7288	ISO	54
67.00	77.60	5.30	CO 7344	ISO	55
67.94	73.18	2.62	CO 3103	AS568	40
69.00	77.00	4.00	CO 00305	V	37
69.00	76.10	3.55	CO 7289	ISO	54
69.00	79.60	5.30	CO 7345	ISO	55
69.22	79.88	5.33	CO 0437	AS568	43
69.40	75.60	3.10	CO 00209	G	30
69.44	76.50	3.53	CO 0359	AS568	41
69.50	73.50	2.00	CO 0546	S	35
69.52	74.76	2.62	CO 4718	AS568	40
69.57	73.13	1.78	CO 4699	AS568	38
69.60	81.00	5.70	CO 00060	P	24
70.50	74.50	2.00	CO 0547	S	35
70.60	77.60	3.50	CO 0649	JASO	52
70.60	75.40	2.40	CO 0648	JASO	48
70.60	82.00	5.70	CO 00061	P	24
71.00	78.10	3.55	CO 7290	ISO	54
71.00	81.60	5.30	CO 7346	ISO	55
71.12	76.36	2.62	CO 6254	AS568	40
72.39	83.05	5.33	CO 0438	AS568	43
72.62	79.68	3.53	CO 0360	AS568	41
72.69	77.93	2.62	CO 6261	AS568	40
72.75	76.31	1.78	CO 4457	AS568	38
73.00	80.10	3.55	CO 7291	ISO	54
73.00	83.60	5.30	CO 7347	ISO	55
74.40	80.60	3.10	CO 00210	G	30

Inside diameter d _o	Outside diameter D	Thickness W	Dimension code	Applicable standard	Page listed
74.50	78.50	2.00	CO 0548	S	35
74.60	86.00	5.70	CO 00062	P	24
74.60	81.60	3.50	CO 0650	JASO	52
75.00	82.10	3.55	CO 7292	ISO	55
75.00	85.60	5.30	CO 7348	ISO	55
75.56	86.22	5.33	CO 0439	AS568	43
75.79	82.85	3.53	CO 0361	AS568	41
75.87	81.11	2.62	CO 6268	AS568	40
75.92	79.48	1.78	CO 7129	AS568	38
77.50	84.60	3.55	CO 7293	ISO	55
77.50	88.10	5.30	CO 7349	ISO	55
78.74	89.40	5.33	CO 0440	AS568	43
78.97	86.03	3.53	CO 0362	AS568	41
79.40	85.60	3.10	CO 00211	G	30
79.50	83.50	2.00	CO 0549	S	35
79.60	91.00	5.70	CO 00063	P	24
79.60	86.60	3.50	CO 0651	JASO	52
80.00	87.10	3.55	CO 7294	ISO	55
80.00	90.60	5.30	CO 7350	ISO	55
81.92	92.58	5.33	CO 0441	AS568	43
82.14	89.20	3.53	CO 0363	AS568	41
82.22	87.46	2.62	CO 6276	AS568	40
82.27	85.83	1.78	CO 4335	AS568	38
82.50	89.60	3.55	CO 7295	ISO	55
82.50	93.10	5.30	CO 7351	ISO	55
84.00	92.00	4.00	CO 00306	V	37
84.40	90.60	3.10	CO 00212	G	30
84.50	88.50	2.00	CO 0550	S	35
84.60	91.60	3.50	CO 0652	JASO	52
84.60	96.00	5.70	CO 00064	P	24
85.00	92.10	3.55	CO 7296	ISO	55
85.00	95.60	5.30	CO 7352	ISO	55
85.09	95.75	5.33	CO 0442	AS568	43
85.32	92.38	3.53	CO 0364	AS568	41
87.50	94.60	3.55	CO 7297	ISO	55
87.50	98.10	5.30	CO 7353	ISO	55
88.26	98.92	5.33	CO 0443	AS568	43
88.49	95.55	3.53	CO 0365	AS568	41
88.57	93.81	2.62	CO 3568	AS568	40
88.62	92.18	1.78	CO 3010	AS568	38
89.40	95.60	3.10	CO 00213	G	30
89.50	93.50	2.00	CO 0551	S	35
89.60	101.00	5.70	CO 00065	P	24
89.60	96.60	3.50	CO 0653	JASO	52
90.00	97.10	3.55	CO 7298	ISO	55
90.00	100.60	5.30	CO 7354	ISO	55
91.44	102.10	5.33	CO 0444	AS568	43
91.67	98.73	3.53	CO 0366	AS568	41
92.50	99.60	3.55	CO 7299	ISO	55
92.50	103.10	5.30	CO 7355	ISO	55
94.40	100.60	3.10	CO 00214	G	30
94.50	98.50	2.00	CO 0552	S	35
94.60	106.00	5.70	CO 00066	P	24
94.60	101.60	3.50	CO 0654	JASO	52
94.62	105.28	5.33	CO 0445	AS568	43
94.84	101.90	3.53	CO 0367	AS568	41
94.92	100.16	2.62	CO 4837	AS568	40
94.97	98.53	1.78	CO 8205	AS568	38
95.00	102.10	3.55	CO 7300	ISO	55
95.00	105.60	5.30	CO 7356	ISO	55
97.50	104.60	3.55	CO 7301	ISO	55
97.50	108.10	5.30	CO 7357	ISO	55
97.79	108.45	5.33	CO 0446	AS568	43
98.02	105.08	3.53	CO 0368	AS568	41
99.00	107.00	4.00	CO 00307	V	37
99.40	105.60	3.10	CO 00215	G	30
99.50	103.50	2.00	CO 0553	S	35
99.60	111.00	5.70	CO 00067	P	24
99.60	106.60	3.50	CO 0655	JASO	52
100.00	107.10	3.55	CO 7302	ISO	55

*In the table above, the following indications are used:
 •Former JASO → JASO •ISO equivalent → ISO

Inside diameter d ₀	Outside diameter D	Thickness W	Dimension code	Applicable standard	Page listed
100.00	110.60	5.30	CO 7358	ISO	55
100.96	111.62	5.33	CO 0447	AS568	43
101.19	108.25	3.53	CO 0369	AS568	41
101.27	106.51	2.62	CO 7031	AS568	40
101.32	104.88	1.78	CO 4251	AS568	38
101.60	113.00	5.70	CO 00068	P	24
103.00	110.10	3.55	CO 7303	ISO	55
103.00	113.60	5.30	CO 7359	ISO	55
104.14	114.80	5.33	CO 0448	AS568	43
104.37	111.43	3.53	CO 0370	AS568	41
104.40	110.60	3.10	CO 00216	G	30
104.50	108.50	2.00	CO 0554	S	35
104.60	116.00	5.70	CO 00069	P	24
105.60	112.60	3.50	CO 0656	JASO	52
106.00	113.10	3.55	CO 7304	ISO	55
106.00	116.60	5.30	CO 7360	ISO	55
107.32	117.98	5.33	CO 0449	AS568	43
107.54	114.60	3.53	CO 0371	AS568	41
107.62	112.86	2.62	CO 1640	AS568	40
107.67	111.23	1.78	CO 4873	AS568	38
109.00	116.10	3.55	CO 7305	ISO	55
109.00	119.60	5.30	CO 7361	ISO	55
109.00	123.00	7.00	CO 7407	ISO	56
109.40	115.60	3.10	CO 00217	G	30
109.50	113.50	2.00	CO 0555	S	35
109.60	121.00	5.70	CO 00070	P	24
110.49	121.15	5.33	CO 0450	AS568	43
110.72	117.78	3.53	CO 0372	AS568	41
111.50	115.50	2.00	CO 0556	S	35
111.60	123.00	5.70	CO 00071	P	24
111.60	118.60	3.50	CO 0657	JASO	52
112.00	119.10	3.55	CO 7306	ISO	55
112.00	122.60	5.30	CO 7362	ISO	55
112.00	126.00	7.00	CO 7408	ISO	56
113.66	124.32	5.33	CO 0451	AS568	43
113.66	127.62	6.98	CO 0487	AS568	44
113.89	120.95	3.53	CO 0373	AS568	41
113.97	119.21	2.62	CO 5357	AS568	40
114.02	117.58	1.78	CO 4947	AS568	38
114.40	120.60	3.10	CO 00218	G	30
114.50	118.50	2.00	CO 0557	S	35
114.60	126.00	5.70	CO 00072	P	24
115.00	122.10	3.55	CO 7307	ISO	55
115.00	125.60	5.30	CO 7363	ISO	55
115.00	129.00	7.00	CO 7409	ISO	56
116.84	127.50	5.33	CO 6340	AS568	43
116.84	130.80	6.98	CO 0452	AS568	44
117.07	124.13	3.53	CO 0374	AS568	41
117.60	124.60	3.50	CO 0658	JASO	52
118.00	125.10	3.55	CO 7308	ISO	55
118.00	128.60	5.30	CO 7364	ISO	55
118.00	132.00	7.00	CO 7410	ISO	56
119.00	127.00	4.00	CO 00308	V	37
119.40	125.60	3.10	CO 00219	G	30
119.50	123.50	2.00	CO 0558	S	35
119.60	131.00	5.70	CO 00073	P	24
120.02	130.68	5.33	CO 7779	AS568	43
120.02	133.98	6.98	CO 0453	AS568	44
120.24	127.30	3.53	CO 1672	AS568	41
120.32	125.56	2.62	CO 6356	AS568	40
120.37	123.93	1.78	CO 4252	AS568	39
122.00	129.10	3.55	CO 7309	ISO	55
122.00	132.60	5.30	CO 7365	ISO	55
122.00	136.00	7.00	CO 7411	ISO	56
123.19	133.85	5.33	CO 4133	AS568	43
123.19	137.15	6.98	CO 0454	AS568	44
123.42	130.48	3.53	CO 1680	AS568	41
124.40	130.60	3.10	CO 00220	G	30
124.50	128.50	2.00	CO 0559	S	35
124.60	136.00	5.70	CO 00074	P	24

Inside diameter d ₀	Outside diameter D	Thickness W	Dimension code	Applicable standard	Page listed
124.60	131.60	3.50	CO 0659	JASO	52
125.00	132.10	3.55	CO 7310	ISO	55
125.00	135.60	5.30	CO 7366	ISO	55
125.00	139.00	7.00	CO 7412	ISO	56
126.36	137.02	5.33	CO 6366	AS568	43
126.36	140.32	6.98	CO 0455	AS568	44
126.59	133.65	3.53	CO 1691	AS568	41
126.67	131.91	2.62	CO 7811	AS568	40
126.72	130.28	1.78	CO 8463	AS568	39
128.00	135.10	3.55	CO 7311	ISO	55
128.00	138.60	5.30	CO 7367	ISO	55
128.00	142.00	7.00	CO 7413	ISO	56
129.40	135.60	3.10	CO 00221	G	30
129.50	133.50	2.00	CO 0560	S	35
129.54	140.20	5.33	CO 4205	AS568	43
129.54	143.50	6.98	CO 0456	AS568	44
129.60	141.00	5.70	CO 00075	P	24
129.77	136.83	3.53	CO 1705	AS568	41
131.50	135.50	2.00	CO 0561	S	35
131.60	143.00	5.70	CO 00076	P	24
131.60	138.60	3.50	CO 0660	JASO	52
132.00	139.10	3.55	CO 7312	ISO	55
132.00	142.60	5.30	CO 7368	ISO	55
132.00	146.00	7.00	CO 7414	ISO	56
132.72	143.38	5.33	CO 5131	AS568	43
132.72	146.68	6.98	CO 0457	AS568	44
132.94	140.00	3.53	CO 1717	AS568	41
133.02	138.26	2.62	CO 1720	AS568	40
133.07	136.63	1.78	CO 4948	AS568	39
134.40	140.60	3.10	CO 00222	G	30
134.50	138.50	2.00	CO 0562	S	35
134.60	146.00	5.70	CO 00077	P	24
135.89	146.55	5.33	CO 6385	AS568	43
135.89	149.85	6.98	CO 0458	AS568	44
136.00	143.10	3.55	CO 7313	ISO	55
136.00	146.60	5.30	CO 7369	ISO	55
136.00	150.00	7.00	CO 7415	ISO	56
136.12	143.18	3.53	CO 4047	AS568	41
139.06	153.02	6.98	CO 0459	AS568	44
139.07	149.73	5.33	CO 5317	AS568	43
139.29	146.35	3.53	CO 1744	AS568	41
139.37	144.61	2.62	CO 4812	AS568	40
139.40	145.60	3.10	CO 00223	G	30
139.50	143.50	2.00	CO 0563	S	35
139.60	151.00	5.70	CO 00078	P	24
139.60	146.60	3.50	CO 0661	JASO	52
140.00	147.10	3.55	CO 7314	ISO	55
140.00	150.60	5.30	CO 7370	ISO	55
140.00	154.00	7.00	CO 7416	ISO	56
142.24	152.90	5.33	CO 7782	AS568	43
142.24	156.20	6.98	CO 0460	AS568	44
142.47	149.53	3.53	CO 1762	AS568	41
144.40	150.60	3.10	CO 00224	G	30
144.50	148.50	2.00	CO 0564	S	35
144.60	156.00	5.70	CO 00079	P	24
145.00	152.10	3.55	CO 7315	ISO	55
145.00	155.60	5.30	CO 7371	ISO	55
145.00	159.00	7.00	CO 7417	ISO	56
145.42	156.08	5.33	CO 4111	AS568	43
145.42	159.38	6.98	CO 0461	AS568	44
145.64	152.70	3.53	CO 1774	AS568	41
145.72	150.96	2.62	CO 7130	AS568	40
148.50	156.50	4.00	CO 00309	V	37
148.59	159.25	5.33	CO 8429	AS568	43
148.59	162.55	6.98	CO 0462	AS568	44
148.82	155.88	3.53	CO 1786	AS568	41
149.30	160.70	5.70	CO 00225	G	30
149.50	153.50	2.00	CO 0565	S	35
149.50	166.30	8.40	CO 00080	P	24
149.60	156.60	3.50	CO 0662	JASO	52

*In the table above, the following indications are used:

•Former JASO → JASO •ISO equivalent → ISO

Even for O-rings for the dimensions given in this table, it may be necessary to prepare new tooling depending on the material used. For more details, please refer to the page on which the O-ring is listed.

Inside diameter d _o	Outside diameter D	Thickness W	Dimension code	Applicable standard	Page listed
149.60	161.00	5.70	CO 00081	P	24
150.00	157.10	3.55	CO 7316	ISO	55
150.00	160.60	5.30	CO 7372	ISO	55
150.00	164.00	7.00	CO 7418	ISO	56
151.76	165.72	6.98	CO 0463	AS568	44
151.77	162.43	5.33	CO 7783	AS568	43
151.99	159.05	3.53	CO 1805	AS568	41
152.07	157.31	2.62	CO 1808	AS568	40
154.30	165.70	5.70	CO 00226	G	30
154.50	171.30	8.40	CO 00082	P	24
155.00	162.10	3.55	CO 7317	ISO	55
155.00	165.60	5.30	CO 7373	ISO	55
155.00	169.00	7.00	CO 7419	ISO	56
158.12	168.78	5.33	CO 7784	AS568	43
158.12	172.08	6.98	CO 0464	AS568	44
158.34	165.40	3.53	CO 1829	AS568	41
158.42	163.66	2.62	CO 1830	AS568	40
159.30	170.70	5.70	CO 00227	G	30
159.50	176.30	8.40	CO 00083	P	24
160.00	167.10	3.55	CO 7318	ISO	55
160.00	170.60	5.30	CO 7374	ISO	55
160.00	174.00	7.00	CO 7420	ISO	56
164.30	175.70	5.70	CO 00228	G	30
164.46	178.42	6.98	CO 0465	AS568	44
164.47	175.13	5.33	CO 7785	AS568	43
164.50	181.30	8.40	CO 00084	P	24
164.69	171.75	3.53	CO 1856	AS568	41
164.77	170.01	2.62	CO 5411	AS568	40
165.00	172.10	3.55	CO 7319	ISO	55
165.00	175.60	5.30	CO 7375	ISO	55
165.00	179.00	7.00	CO 7421	ISO	56
169.30	180.70	5.70	CO 00229	G	30
169.50	186.30	8.40	CO 00085	P	24
170.00	177.10	3.55	CO 7320	ISO	55
170.00	180.60	5.30	CO 7376	ISO	55
170.00	184.00	7.00	CO 7422	ISO	56
170.82	181.48	5.33	CO 7786	AS568	43
170.82	184.78	6.98	CO 0466	AS568	44
171.04	178.10	3.53	CO 1880	AS568	41
171.12	176.36	2.62	CO 6432	AS568	40
173.00	181.00	4.00	CO 00310	V	37
174.30	185.70	5.70	CO 00230	G	30
174.50	191.30	8.40	CO 00086	P	24
175.00	182.10	3.55	CO 7321	ISO	55
175.00	185.60	5.30	CO 7377	ISO	55
175.00	189.00	7.00	CO 7423	ISO	56
177.16	191.12	6.98	CO 0467	AS568	44
177.17	187.83	5.33	CO 7787	AS568	43
177.39	184.45	3.53	CO 1893	AS568	42
177.47	182.71	2.62	CO 6437	AS568	40
179.30	190.70	5.70	CO 00231	G	30
179.50	196.30	8.40	CO 00087	P	24
180.00	187.10	3.55	CO 7322	ISO	55
180.00	190.60	5.30	CO 7378	ISO	55
180.00	194.00	7.00	CO 7424	ISO	56
183.52	194.18	5.33	CO 7819	AS568	43
183.52	197.48	6.98	CO 0468	AS568	44
183.74	190.80	3.53	CO 1915	AS568	42
183.82	189.06	2.62	CO 6445	AS568	40
184.30	195.70	5.70	CO 00232	G	30
184.50	201.30	8.40	CO 00088	P	24
185.00	192.10	3.55	CO 7323	ISO	55
185.00	195.60	5.30	CO 7379	ISO	55
185.00	199.00	7.00	CO 7425	ISO	56
189.30	200.70	5.70	CO 00233	G	30
189.50	206.30	8.40	CO 00089	P	24
189.86	200.52	5.33	CO 3417	AS568	43
189.86	203.82	6.98	CO 0469	AS568	44
190.00	197.10	3.55	CO 7324	ISO	55
190.00	200.60	5.30	CO 7380	ISO	55

Inside diameter d _o	Outside diameter D	Thickness W	Dimension code	Applicable standard	Page listed
190.00	204.00	7.00	CO 7426	ISO	56
190.09	197.15	3.53	CO 1931	AS568	42
190.17	195.41	2.62	CO 8470	AS568	40
194.30	205.70	5.70	CO 00234	G	30
194.50	211.30	8.40	CO 00090	P	24
195.00	202.10	3.55	CO 7325	ISO	55
195.00	205.60	5.30	CO 7381	ISO	55
195.00	209.00	7.00	CO 7427	ISO	56
196.22	206.88	5.33	CO 1945	AS568	43
196.22	210.18	6.98	CO 0470	AS568	44
196.44	203.50	3.53	CO 1946	AS568	42
196.52	201.76	2.62	CO 5303	AS568	40
199.30	210.70	5.70	CO 00235	G	30
199.50	216.30	8.40	CO 00091	P	24
200.00	207.10	3.55	CO 7326	ISO	55
200.00	210.60	5.30	CO 7382	ISO	55
200.00	214.00	7.00	CO 7428	ISO	56
202.56	216.52	6.98	CO 0471	AS568	44
202.57	213.23	5.33	CO 7789	AS568	43
202.79	209.85	3.53	CO 1959	AS568	42
202.87	208.11	2.62	CO 7775	AS568	40
204.30	215.70	5.70	CO 01968	G	30
204.50	221.30	8.40	CO 00092	P	26
206.00	216.60	5.30	CO 7383	ISO	55
206.00	220.00	7.00	CO 7429	ISO	56
208.50	225.30	8.40	CO 00093	P	26
208.92	219.58	5.33	CO 7790	AS568	43
209.14	216.20	3.53	CO 1979	AS568	42
209.22	214.46	2.62	CO 5270	AS568	40
209.30	220.70	5.70	CO 00236	G	30
209.50	226.30	8.40	CO 00094	P	26
212.00	222.60	5.30	CO 7384	ISO	55
212.00	226.00	7.00	CO 7430	ISO	56
214.30	225.70	5.70	CO 03303	G	30
214.50	231.30	8.40	CO 00095	P	26
215.26	229.22	6.98	CO 0472	AS568	44
215.27	225.93	5.33	CO 6492	AS568	43
215.49	222.55	3.53	CO 1990	AS568	42
215.57	220.81	2.62	CO 7776	AS568	40
218.00	228.60	5.30	CO 7385	ISO	55
218.00	232.00	7.00	CO 7431	ISO	56
219.30	230.70	5.70	CO 00237	G	30
219.50	236.30	8.40	CO 00096	P	26
221.62	232.28	5.33	CO 7791	AS568	43
221.84	228.90	3.53	CO 2001	AS568	42
221.92	227.16	2.62	CO 8187	AS568	40
222.50	234.50	6.00	CO 00311	V	37
224.00	234.60	5.30	CO 7386	ISO	55
224.00	238.00	7.00	CO 7432	ISO	56
224.30	235.70	5.70	CO 02011	G	30
224.50	241.30	8.40	CO 00097	P	26
227.96	241.92	6.98	CO 0473	AS568	44
227.97	238.63	5.33	CO 7792	AS568	43
228.19	235.25	3.53	CO 2018	AS568	42
228.27	233.51	2.62	CO 8534	AS568	40
229.30	240.70	5.70	CO 00238	G	30
229.50	246.30	8.40	CO 00098	P	26
230.00	240.60	5.30	CO 7387	ISO	55
230.00	244.00	7.00	CO 7433	ISO	56
234.30	245.70	5.70	CO 02031	G	30
234.32	244.98	5.33	CO 7793	AS568	43
234.50	251.30	8.40	CO 00099	P	26
234.54	241.60	3.53	CO 2032	AS568	42
234.62	239.86	2.62	DO 1122	AS568	40
236.00	246.60	5.30	CO 7388	ISO	55
236.00	250.00	7.00	CO 7434	ISO	56
239.30	250.70	5.70	CO 00239	G	30
239.50	256.30	8.40	CO 00100	P	26
240.66	254.62	6.98	CO 0474	AS568	44
240.67	251.33	5.33	CO 8801	AS568	43

*In the table above, the following indications are used:
 •Former JASO → JASO •ISO equivalent → ISO

Inside diameter d _o	Outside diameter D	Thickness W	Dimension code	Applicable standard	Page listed
240.89	247.95	3.53	CO 2050	AS568	42
240.97	246.21	2.62	DO 1123	AS568	40
243.00	253.60	5.30	CO 7389	ISO	55
243.00	257.00	7.00	CO 7435	ISO	56
244.30	255.70	5.70	CO 02060	G	30
244.50	261.30	8.40	CO 00101	P	26
247.02	257.68	5.33	CO 8803	AS568	43
247.24	254.30	3.53	CO 2064	AS568	42
247.32	252.56	2.62	DO 1124	AS568	40
249.30	260.70	5.70	CO 00240	G	30
249.50	266.30	8.40	CO 00102	P	26
250.00	260.60	5.30	CO 7390	ISO	55
250.00	264.00	7.00	CO 7436	ISO	56
253.36	267.32	6.98	CO 0475	AS568	44
253.37	264.03	5.33	CO 7794	AS568	43
253.59	260.65	3.53	CO 3415	AS568	42
254.30	265.70	5.70	CO 02079	G	30
254.50	271.30	8.40	CO 00103	P	26
258.00	268.60	5.30	CO 7391	ISO	56
258.00	272.00	7.00	CO 7437	ISO	56
259.30	270.70	5.70	CO 00241	G	30
259.50	276.30	8.40	CO 00104	P	26
264.30	275.70	5.70	CO 06543	G	32
264.50	281.30	8.40	CO 00105	P	26
265.00	275.60	5.30	CO 7392	ISO	56
265.00	279.00	7.00	CO 7438	ISO	56
266.06	280.02	6.98	CO 0476	AS568	44
266.07	276.73	5.33	CO 4905	AS568	43
266.29	273.35	3.53	CO 5748	AS568	42
269.30	280.70	5.70	CO 00242	G	32
269.50	286.30	8.40	CO 00106	P	26
272.00	284.00	6.00	CO 00312	V	37
272.00	282.60	5.30	CO 7393	ISO	56
272.00	286.00	7.00	CO 7439	ISO	56
274.30	285.70	5.70	CO 02100	G	32
274.50	291.30	8.40	CO 00107	P	26
278.76	292.72	6.98	CO 0477	AS568	44
278.77	289.43	5.33	CO 7795	AS568	43
278.99	286.05	3.53	CO 5393	AS568	42
279.30	290.70	5.70	CO 00243	G	32
279.50	296.30	8.40	CO 00108	P	26
280.00	290.60	5.30	CO 7394	ISO	56
280.00	294.00	7.00	CO 7440	ISO	56
284.30	295.70	5.70	CO 03210	G	32
284.50	301.30	8.40	CO 00109	P	26
289.30	300.70	5.70	CO 00244	G	32
289.50	306.30	8.40	CO 00110	P	26
290.00	300.60	5.30	CO 7395	ISO	56
290.00	304.00	7.00	CO 7441	ISO	56
291.46	305.42	6.98	CO 0478	AS568	44
291.47	302.13	5.33	CO 8851	AS568	44
291.69	298.75	3.53	CO 2132	AS568	42
294.30	305.70	5.70	CO 06566	G	32
294.50	311.30	8.40	CO 00111	P	26
299.30	310.70	5.70	CO 00245	G	32
299.50	316.30	8.40	CO 00112	P	26
300.00	310.60	5.30	CO 7396	ISO	56
300.00	314.00	7.00	CO 7442	ISO	56
304.16	318.12	6.98	CO 0479	AS568	44
304.17	314.83	5.33	CO 4906	AS568	44
304.30	315.70	5.70	DO 01137	G	32
304.39	311.45	3.53	CO 4602	AS568	42
304.50	321.30	8.40	CO 02147	P	26
307.00	317.60	5.30	CO 7397	ISO	56
307.00	321.00	7.00	CO 7443	ISO	56
309.30	320.70	5.70	CO 02158	G	32
309.50	326.30	8.40	CO 08835	P	26
314.50	331.30	8.40	CO 00113	P	26
315.00	325.60	5.30	CO 7398	ISO	56
315.00	329.00	7.00	CO 7444	ISO	56

Inside diameter d _o	Outside diameter D	Thickness W	Dimension code	Applicable standard	Page listed
316.86	330.82	6.98	CO 0480	AS568	44
319.30	330.70	5.70	CO 02176	G	32
319.50	336.30	8.40	CO 00114	P	26
321.50	333.50	6.00	CO 00313	V	37
324.50	341.30	8.40	CO 08836	P	26
325.00	335.60	5.30	CO 7399	ISO	56
325.00	339.00	7.00	CO 7445	ISO	56
329.30	340.70	5.70	CO 08813	G	32
329.50	346.30	8.40	CO 07645	P	26
329.56	343.52	6.98	CO 0481	AS568	44
329.57	340.23	5.33	CO 7797	AS568	44
329.79	336.85	3.53	CO 2192	AS568	42
334.30	345.70	5.70	CO 08814	G	32
334.50	351.30	8.40	CO 00115	P	26
335.00	345.60	5.30	CO 7400	ISO	56
335.00	349.00	7.00	CO 7446	ISO	56
339.30	350.70	5.70	CO 02206	G	32
339.50	356.30	8.40	CO 00116	P	26
342.26	356.22	6.98	CO 0482	AS568	44
344.30	355.70	5.70	CO 02216	G	32
344.50	361.30	8.40	CO 08837	P	26
345.00	355.60	5.30	CO 7401	ISO	56
345.00	359.00	7.00	CO 7447	ISO	56
349.30	360.70	5.70	CO 02223	G	32
349.50	366.30	8.40	CO 06615	P	26
349.50	365.70	5.70	CO 08815	G	32
354.30	365.70	5.70	CO 08815	G	32
354.50	371.30	8.40	CO 00117	P	26
354.96	368.92	6.98	CO 0483	AS568	44
354.97	365.63	5.33	CO 7798	AS568	44
355.00	365.60	5.30	CO 7402	ISO	56
355.00	369.00	7.00	CO 7448	ISO	56
355.19	362.25	3.53	CO 4549	AS568	42
359.30	370.70	5.70	CO 02244	G	32
359.50	376.30	8.40	CO 00118	P	26
364.50	381.30	8.40	CO 06630	P	26
365.00	375.60	5.30	CO 7403	ISO	56
365.00	379.00	7.00	CO 7449	ISO	56
367.66	381.62	6.98	CO 0484	AS568	44
369.50	386.30	8.40	CO 08838	P	26
374.30	385.70	5.70	CO 08818	G	32
374.50	391.30	8.40	CO 00119	P	26
375.00	385.60	5.30	CO 7404	ISO	56
375.00	389.00	7.00	CO 7450	ISO	56
376.00	388.00	6.00	CO 00314	V	37
379.30	390.70	5.70	CO 02272	G	32
379.50	396.30	8.40	CO 02274	P	26
380.36	394.32	6.98	CO 0485	AS568	44
380.37	391.03	5.33	CO 6643	AS568	44
380.59	387.65	3.53	CO 02277	AS568	42
384.30	395.70	5.70	CO 08819	G	32
384.50	401.30	8.40	CO 00120	P	26
387.00	397.60	5.30	CO 7405	ISO	56
387.00	401.00	7.00	CO 7451	ISO	56
389.30	400.70	5.70	CO 02287	G	32
389.50	406.30	8.40	CO 06650	P	26
393.06	407.02	6.98	CO 0486	AS568	44
394.30	405.70	5.70	CO 08820	G	32
394.50	411.30	8.40	CO 08839	P	26
399.30	410.70	5.70	CO 02301	G	32
399.50	416.30	8.40	CO 00121	P	26
400.00	410.60	5.30	CO 7406	ISO	56
400.00	414.00	7.00	CO 7452	ISO	56
404.30	415.70	5.70	CO 08821	G	32
404.50	421.30	8.40	CO 02311	P	26
405.26	412.32	3.53	CO 4609	AS568	42
405.26	415.92	5.33	CO 7799	AS568	44
405.26	419.22	6.98	CO 4397	AS568	44
409.30	420.70	5.70	CO 08822	G	32
409.50	426.30	8.40	CO 06663	P	26
412.00	426.00	7.00	CO 7453	ISO	56

*In the table above, the following indications are used:

•Former JASO → JASO •ISO equivalent → ISO

Even for O-rings for the dimensions given in this table, it may be necessary to prepare new tooling depending on the material used. For more details, please refer to the page on which the O-ring is listed.

Inside diameter d ₀	Outside diameter D	Thickness W	Dimension code	Applicable standard	Page listed
414.30	425.70	5.70	CO 02336	G	32
414.50	431.30	8.40	CO 02337	P	26
417.96	431.92	6.98	CO 7806	AS568	44
419.30	430.70	5.70	CO 08823	G	32
419.50	436.30	8.40	CO 08840	P	26
424.30	435.70	5.70	CO 02358	G	32
424.50	441.30	8.40	CO 02359	P	26
425.00	439.00	7.00	CO 7454	ISO	56
425.50	437.50	6.00	CO 00315	V	37
429.30	440.70	5.70	CO 08824	G	32
429.50	446.30	8.40	CO 02371	P	26
430.66	437.72	3.53	CO 6675	AS568	42
430.66	441.32	5.33	CO 8802	AS568	44
430.66	444.62	6.98	CO 7807	AS568	45
434.30	445.70	5.70	CO 08825	G	32
434.50	451.30	8.40	CO 02383	P	28
437.00	451.00	7.00	CO 7455	ISO	56
439.30	450.70	5.70	CO 08826	G	32
439.50	456.30	8.40	CO 08841	P	28
443.36	457.32	6.98	CO 2401	AS568	45
444.30	455.70	5.70	CO 08827	G	32
444.50	461.30	8.40	CO 06681	P	28
449.30	460.70	5.70	CO 02417	G	32
449.50	466.30	8.40	CO 08842	P	28
450.00	464.00	7.00	CO 7456	ISO	56
454.30	465.70	5.70	CO 08828	G	32
454.50	471.30	8.40	CO 02433	P	28
456.06	463.12	3.53	CO 5011	AS568	42
456.06	466.72	5.33	CO 7826	AS568	44
456.06	470.02	6.98	CO 7808	AS568	45
459.30	470.70	5.70	CO 02441	G	32
459.50	476.30	8.40	CO 08843	P	28
462.00	476.00	7.00	CO 6711	ISO	56
464.30	475.70	5.70	CO 06715	G	32
464.50	481.30	8.40	CO 02453	P	28
468.76	482.72	6.98	CO 5107	AS568	45
469.30	480.70	5.70	CO 02460	G	32
469.50	486.30	8.40	CO 08844	P	28
474.30	485.70	5.70	CO 08829	G	32
474.50	491.30	8.40	CO 08845	P	28
475.00	495.00	10.00	CO 00316	V	37
475.00	489.00	7.00	CO 7457	ISO	56
479.30	490.70	5.70	CO 08830	G	32
479.50	496.30	8.40	CO 06734	P	28
481.46	492.12	5.33	CO 7800	AS568	44
481.46	495.42	6.98	CO 4270	AS568	45
484.30	495.70	5.70	CO 08831	G	32
484.50	501.30	8.40	CO 09165	P	28
487.00	501.00	7.00	CO 7458	ISO	56
489.30	500.70	5.70	CO 08832	G	32
489.50	506.30	8.40	DO 09015	P	28
494.16	508.12	6.98	CO 8810	AS568	45
494.30	505.70	5.70	CO 08833	G	32
494.50	511.30	8.40	DO 09016	P	28
499.30	510.70	5.70	CO 08834	G	32
499.50	516.30	8.40	CO 09057	P	28
500.00	514.00	7.00	CO 7459	ISO	56
515.00	529.00	7.00	CO 7460	ISO	56
524.50	544.50	10.00	CO 00317	V	37
530.00	544.00	7.00	CO 7461	ISO	56
545.00	559.00	7.00	CO 7462	ISO	56
560.00	574.00	7.00	CO 7463	ISO	56
579.00	599.00	10.00	CO 00318	V	37
580.00	594.00	7.00	CO 7464	ISO	56
600.00	614.00	7.00	CO 7465	ISO	56
615.00	629.00	7.00	CO 7466	ISO	56
630.00	644.00	7.00	CO 7467	ISO	56
633.50	653.50	10.00	CO 00319	V	37
650.00	664.00	7.00	CO 7468	ISO	56
670.00	684.00	7.00	CO 7469	ISO	56

Inside diameter d ₀	Outside diameter D	Thickness W	Dimension code	Applicable standard	Page listed
683.00	703.00	10.00	CO 00320	V	37
732.50	752.50	10.00	CO 00321	V	37
782.00	802.00	10.00	CO 00322	V	37
836.50	856.50	10.00	CO 00323	V	37
940.50	960.50	10.00	CO 00324	V	37
1044.00	1064.00	10.00	CO 00325	V	37

*In the table above, the following indications are used:
•Former JASO → JASO •ISO equivalent → ISO

NOK Product Lineup

Sealing products

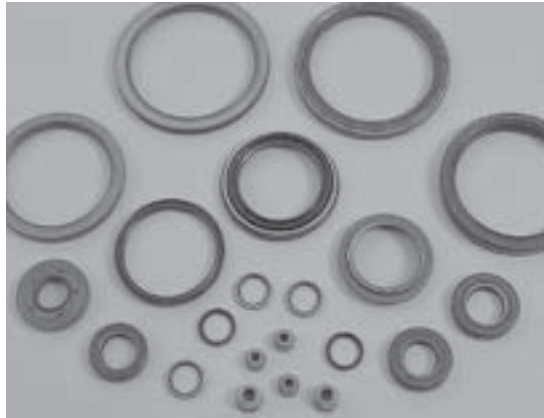

Oil seals

- Oil seals
- Packings
- O-rings
- Metal gaskets "SOFTMETAL"
- Seal washers
- Mechanical seals
- Lip seals
- Segment seals
- Brush seals
- Static metal packings actiseals
- Perfluoroelastomer "KALREZ"
- Magnetic fluid seals

Industrial rubber & resin products



Polyurethane rubber "IRON RUBBER" products

- Industrial rubber products
- Iron rubber products
- Iron rubber belts
- Traffic signs & Safety devices
- Engineering plastic products
- Synthetic rubber "NOXTITE"
- Industrial chemical products "CHEMINOX"
- Phenolic molding material

Vibration damping products Sound isolator products



Anti-vibration rubber

- Vibration damping products
- Sound isolator products

Fluid power equipment



Accumulators

- Accumulators
- Housing and related equipments

Plant equipment



Metal bellows (Welding bellows)

- Metal bellows
- Couplings

Electronics products

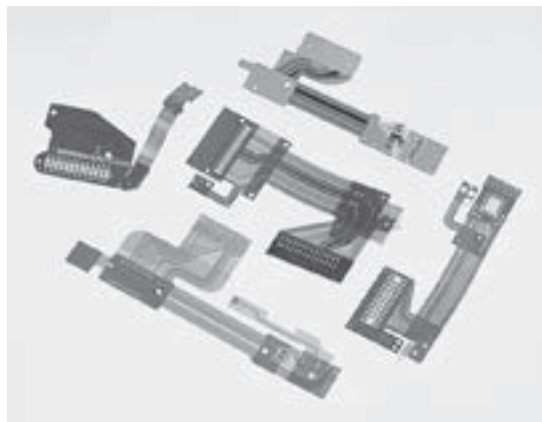

Flexible circuits

- Flexible printed circuit
- Precision rubber / resin parts

Industrial function parts & special parts



Special lubricant

- Polymer hollow fiber membrane modules
- Solenoids
- Actuators
- Oil-less bearing "LUBLESS"
- Adapters for cable breaking "SY JOINT"
- Special lubricant
- Fluorine base coating material "GLEITPAN"
- Fluorine base water repellent & oil repellent agents "NOXBARRIER"
- Compressor valves
- Recoil starters

OA equipment products

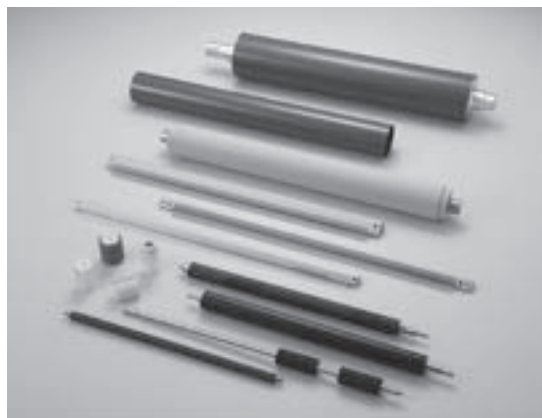

OA equipment products

- OA equipment products

Appendix

Shaft Tolerances and Dimensions

Unit: 0.001mm

Shaft Tolerances and Dimensions (JIS B 0401)

Classification of nominal dimension (mm)	IT 5		IT 6		IT 7		IT 8		IT 9		IT 10		IT 11		IT 12																																																										
	m5	k5	j5	h5	r6	p6	n6	m6	k6	j6	h6	g6	f6	IT	s7	r7	p7	n7	m7	k7	j7	h7	g7	f7	e7	IT	h8	f8	e8	d8	IT	h9	e9	d9	c9	b9	IT	h10	e10	d10	c10	b10	IT	h11	e11	d11	c11	b11	IT	h12	e12	d12	c12	b12																			
1 - 3	+6	+4	0	0	+16	+12	+10	+8	+6	0	-2	-6	10	+24	+21	+18	+15	—	—	—	+7	0	-3	-6	-14	14	+46	+41	+36	+30	+25	+19	+12	0	-6	-16	-32	27	+28	+23	+18	+12	+7	1	-6	-18	-24	-34	-50	27	+46	+41	+36	+30	+25	+19	+12	0	-6	-16	-32	27	+28	+23	+18	+12	+7	1	-6	-18	-24	-34	-50
3 - 6	+9	+6	0	0	+23	+20	+16	+12	+9	0	-4	-10	12	+31	+27	+24	+20	—	—	—	+9	0	-4	-10	-20	18	+38	+34	+30	+25	+21	+16	+10	0	-5	-13	-25	22	+43	+38	+34	+29	+23	+17	+11	-5	-15	-20	-28	-40	22	+43	+38	+34	+29	+23	+17	+11	-5	-15	-20	-28	-40										
6 - 10	+12	+7	0	0	+28	+24	+19	+15	+10	0	-5	-13	15	+38	+34	+30	+25	+21	+16	+10	0	-5	-13	-25	22	+43	+38	+34	+29	+23	+17	+11	0	-5	-15	-28	-40	22	+43	+38	+34	+29	+23	+17	+11	-5	-15	-20	-28	-40	22	+43	+38	+34	+29	+23	+17	+11	-5	-15	-20	-28	-40										
10 - 14	+15	+9	0	0	+34	+29	+23	+18	+12	0	-6	-16	18	+46	+41	+36	+30	+25	+19	+12	0	-6	-16	-32	27	+46	+41	+36	+30	+25	+19	+12	0	-6	-16	-32	27	+46	+41	+36	+30	+25	+19	+12	0	-6	-16	-32	27	+46	+41	+36	+30	+25	+19	+12	0	-6	-16	-32	27												
14 - 18	+7	+1	-3	-8	+23	+18	+12	+7	+1	-3	-11	-17	-27	+23	+18	+12	+7	+1	-3	-11	-17	-27	18	+23	+18	+12	+7	+1	-3	-11	-17	-27	18	+23	+18	+12	+7	+1	-3	-11	-17	-27	18	+23	+18	+12	+7	+1	-3	-11	-17	-27	18																				
18 - 24	+17	+11	0	0	+41	+35	+28	+21	+15	+9	0	-7	-20	21	+56	+49	+43	+36	+29	+23	+17	+11	-7	-20	-40	33	+62	+55	+48	+41	+34	+27	+20	+13	+6	+0	-10	-20	33	+62	+55	+48	+41	+34	+27	+20	+13	+6	+0	-10	-20	33	+62	+55	+48	+41	+34	+27	+20	+13	+6	+0	-10	-20	33								
24 - 30	+8	+2	-4	-9	+28	+22	+15	+8	+2	-4	-13	-20	-33	+28	+22	+15	+8	+2	-4	-13	-20	-33	21	+35	+28	+22	+15	+8	+2	-4	-13	-20	-33	21	+35	+28	+22	+15	+8	+2	-4	-13	-20	-33	21	+35	+28	+22	+15	+8	+2	-4	-13	-20	-33	21																	
30 - 40	+20	+13	0	0	+50	+42	+33	+25	+18	+11	0	-9	-25	25	+68	+59	+51	+42	+34	+26	+17	+9	0	-9	-25	25	+68	+59	+51	+42	+34	+26	+17	+9	0	-9	-25	25	+68	+59	+51	+42	+34	+26	+17	+9	0	-9	-25	25	+68	+59	+51	+42	+34	+26	+17	+9	0	-9	-25	25											
40 - 50	+9	+2	-5	-11	+34	+26	+17	+9	+2	-5	-16	-25	-41	+34	+26	+17	+9	+2	-5	-16	-25	-41	25	+43	+34	+26	+17	+9	+2	-5	-16	-25	-41	25	+43	+34	+26	+17	+9	+2	-5	-16	-25	-41	25	+43	+34	+26	+17	+9	+2	-5	-16	-25	-41	25																	
50 - 65	+24	+15	0	0	+62	+51	+39	+30	+21	+12	0	-10	-30	30	+83	+71	+62	+50	+41	+32	+23	+14	0	-10	-30	30	+83	+71	+62	+50	+41	+32	+23	+14	0	-10	-30	30	+83	+71	+62	+50	+41	+32	+23	+14	0	-10	-30	30	+83	+71	+62	+50	+41	+32	+23	+14	0	-10	-30	30											
65 - 80	+11	+2	-7	-13	+62	+32	+20	+11	+2	-7	-19	-29	-49	+62	+32	+20	+11	+2	-7	-19	-29	-49	30	+89	+73	+63	+53	+43	+33	+23	+13	+3	+0	-12	-30	-40	-60	90	+93	+83	+73	+63	+53	+43	+33	+23	+13	+3	+0	-12	-30	-40	-60	90																			
80 - 100	+28	+18	0	0	+73	+59	+45	+35	+25	+13	0	-12	-36	35	+106	+86	+72	+58	+48	+38	+28	+18	0	-12	-36	35	+106	+86	+72	+58	+48	+38	+28	+18	0	-12	-36	35	+106	+86	+72	+58	+48	+38	+28	+18	0	-12	-36	35	+106	+86	+72	+58	+48	+38	+28	+18	0	-12	-36	35											
100 - 120	+13	+3	-9	-15	+76	+37	+23	+13	+3	-9	-22	-34	-58	+76	+37	+23	+13	+3	-9	-22	-34	-58	35	+114	+89	+73	+63	+53	+43	+33	+23	+13	+3	+0	-15	-35	-47	-71	-107	107	+114	+89	+73	+63	+53	+43	+33	+23	+13	+3	+0	-15	-35	-47	-71	-107	107																
120 - 140	+33	+21	0	0	+90	+68	+52	+40	+28	+14	0	-14	-43	40	+140	+105	+83	+67	+55	+43	+31	+22	0	-14	-43	40	+140	+105	+83	+67	+55	+43	+31	+22	0	-14	-43	40	+140	+105	+83	+67	+55	+43	+31	+22	0	-14	-43	40	+140	+105	+83	+67	+55	+43	+31	+22	0	-14	-43	40											
140 - 160	+15	+3	-11	-18	+65	+43	+27	+15	+3	-11	-25	-39	-68	+65	+43	+27	+15	+3	-11	-25	-39	-68	40	+100	+85	+68	+53	+43	+33	+23	+13	+3	+0	-18	-40	-54	-83	-125	125	+100	+85	+68	+53	+43	+33	+23	+13	+3	+0	-18	-40	-54	-83	-125	125																		
160 - 180	+93	+68	0	0	+148	+108	+84	+68	+54	+43	+33	+23	+13	132	+132	+103	+88	+73	+63	+53	+43	+33	+23	+13	+3	+0	132	+132	+103	+88	+73	+63	+53	+43	+33	+23	+13	+3	+0	-18	-40	-54	-83	-125	125	+132	+103	+88	+73	+63	+53	+43	+33	+23	+13	+3	+0	-18	-40	-54	-83	-125	125										
180 - 200	+37	+24	0	0	+109	+79	+60	+46	+33	+16	0	-15	-50	46	+176	+126	+96	+77	+63	+50	+35	+25	0	-15	-50	46	+176	+126	+96	+77	+63	+50	+35	+25	0	-15	-50	46	+176	+126	+96	+77	+63	+50	+35	+25	0	-15	-50	46	+176	+126	+96	+77	+63	+50	+35	+25	0	-15	-50	46											
200 - 225	+17	+4	-13	-20	+80	+50	+31	+17	+4	-13	-29	-44	-79	+80	+50	+31	+17	+4	-13	-29	-44	-79	46	+130	+80	+60	+45	+35	+25	+15	+5	+0	-17	-39	-53	-77	-111	111	+130	+80	+60	+45	+35	+25	+15	+5	+0	-17	-39	-53	-77	-111	111																				
225 - 250	+43	+27	0	0	+126	+88	+66	+52	+36	+16	0	-17	-56	52	+188	+130	+100	+84	+70	+56	+42	+28	0	-17	-56	52	+188	+130	+100	+84	+70	+56	+42	+28	0	-17	-56	52	+188	+130	+100	+84	+70	+56	+42	+28	0	-17	-56	52	+188	+130	+100	+84	+70	+56	+42	+28	0	-17	-56	52											
250 - 280	+20	+4	-16	-23	+130	+84	+62	+48	+34	+20	0	-17	-56	52	+222	+150	+100	+84	+70	+56	+42	+28	0	-17	-56	52	+222	+150	+100	+84	+70	+56	+42	+28	0	-17	-56	52	+222	+150	+100	+84	+70	+56	+42	+28	0	-17	-56	52	+222	+150	+100	+84	+70	+56	+42	+28	0	-17	-56	52											
280 - 315	+46	+29	0	0	+144	+98	+73	+57	+40	+18	0	-18	-62	57	+247	+165	+119	+94	+78	+61	+44	+29	0	-18	-62	57	+247	+165	+119	+94	+78	+61	+44	+29	0	-18	-62	57	+247	+165	+119	+94	+78	+61	+44	+29	0	-18	-62	57	+247	+165	+119	+94	+78	+61	+44	+29	0	-18	-62	57											
315 - 355	+21	+4	-18	-25	+150	+98	+73	+57	+40	+18	0	-18	-62	57	+265	+171	+126	+100	+84	+70	+56	+42	+28	0	-18	-62	57	+265	+171	+126	+100	+84	+70	+56	+42	+28	0	-18	-62	57	+265	+171	+126	+100	+84	+70	+56	+42	+28	0	-18	-62	57	+265	+171	+126	+100	+84	+70	+56	+42	+28	0	-18	-62	57							
355 - 400	+50	+32	0	0	+166	+108	+80	+63	+45	+20	0	-20	-68	63	+295	+189	+139	+103	+86	+68	+51	+34	+17	0	-20	-68	63	+295	+189	+139	+103	+86	+68	+51	+34	+17	0	-20	-68	63	+295	+189	+139	+103	+86	+68	+51	+34	+17	0	-20	-68	63	+295	+189	+139	+103	+86	+68	+51	+34	+17	0	-20	-68	63							
400 - 450	+23	+5	-20	-27	+172	+108	+80	+63	+45	+2																																																															

Hole Tolerances and Dimensions

Unit: 0.001mm

Hole Tolerances and Dimensions (JIS B 0401)

Classification of nominal dimension (mm)	Unit: 0.001mm																																				
	IT 6	Upper tolerance Lower tolerance						IT 7	Upper tolerance Lower tolerance												IT 8	Upper tolerance Lower tolerance		IT 9	Upper tolerance Lower tolerance		IT 10	Upper tolerance Lower tolerance		IT 12	H 12 Upper tolerance Lower tolerance						
		M 6	K 6	J 6	H 6	G 6	F 6		U 7	T 7	S 7	R 7	P 7	M 7	K 7	J 7	H 7	G 7	F 7	E 7		H 8	F 8		E 8	D 8		H 9	E 9			D 9	C 9	H 10	D 10	C 10	B 10
1 - 3	6	-2	0	2	6	8	12	10	-18	-14	-10	-6	-4	-2	0	3	10	12	16	24	14	+14	+20	+28	+34	25	+25	+39	+45	+85	40	+40	+60	+100	+180	+100	+100
3 - 6	8	-1	2	4	8	12	18	12	-19	-15	-11	-8	-4	0	3	5	12	16	22	32	18	+18	+28	+38	+48	30	+30	+50	+60	+100	48	+48	+78	+118	+188	+120	+120
6 - 10	9	-3	2	5	9	14	22	15	-22	-17	-13	-9	-4	0	5	8	15	20	28	40	22	+22	+35	+47	+62	36	+36	+61	+76	+116	58	+58	+98	+138	+208	+150	+150
10 - 14	11	-4	2	6	11	17	27	18	-26	-21	-16	-11	-5	0	6	10	18	24	34	50	27	+27	+43	+59	+77	43	+43	+75	+93	+138	70	+70	+120	+165	+220	+180	+180
14 - 18	13	-4	2	6	11	17	27	21	-33	-27	-20	-14	-7	0	6	12	21	28	41	61	33	+33	+53	+73	+98	52	+52	+92	+117	+162	84	+84	+149	+194	+244	+210	+210
18 - 24	16	-4	3	10	16	25	41	25	-40	-33	-25	-17	-8	0	7	14	25	34	50	75	39	+39	+64	+89	+119	62	+62	+112	+142	+192	100	+100	+180	+220	+270	+250	+250
24 - 30	19	-5	4	13	19	29	49	30	-51	-41	-31	-21	-11	0	9	18	30	40	60	90	46	+46	+76	+106	+146	74	+74	+134	+174	+224	120	+120	+220	+270	+320	+300	+300
30 - 40	22	-6	4	16	22	34	58	35	-61	-45	-33	-21	-11	0	10	22	35	47	71	107	54	+54	+90	+126	+174	87	+87	+159	+207	+267	140	+140	+260	+320	+380	+350	+350
40 - 50	25	-8	4	16	25	39	68	40	-76	-55	-42	-30	-17	0	11	24	38	52	78	117	63	+63	+106	+148	+208	100	+100	+185	+245	+310	160	+160	+305	+370	+440	+400	+400
50 - 65	29	-8	5	22	29	44	79	46	-91	-64	-48	-32	-21	0	13	26	40	54	83	125	72	+72	+122	+172	+242	115	+115	+215	+285	+375	185	+185	+355	+445	+565	+460	+460
65 - 80	32	-9	5	25	32	49	88	52	-103	-74	-55	-38	-24	0	14	28	42	58	88	133	81	+81	+137	+191	+271	130	+130	+240	+320	+400	210	+210	+400	+500	+600	+520	+520
80 - 100	36	-10	7	29	36	54	98	57	-111	-78	-58	-38	-24	0	15	30	46	61	96	146	89	+89	+151	+214	+299	140	+140	+265	+350	+440	230	+230	+440	+560	+660	+570	+570
100 - 120	40	-10	8	33	40	60	108	63	-121	-85	-62	-41	-26	0	16	33	50	67	100	150	97	+97	+165	+232	+327	155	+155	+290	+385	+480	250	+250	+480	+600	+700	+630	+630
120 - 140	46	-11	10	40	46	70	124	70	-131	-91	-66	-41	-26	0	17	36	54	73	107	162	103	+103	+172	+242	+342	160	+160	+310	+400	+500	260	+260	+500	+630	+730	+660	+660
140 - 160	52	-12	11	47	52	79	139	77	-147	-103	-74	-48	-30	0	18	39	57	77	113	171	109	+109	+180	+251	+351	170	+170	+330	+420	+520	270	+270	+520	+660	+760	+690	+690
160 - 180	57	-13	12	54	57	86	148	81	-159	-109	-79	-52	-32	0	19	42	61	81	117	177	115	+115	+190	+265	+370	180	+180	+350	+440	+540	280	+280	+540	+680	+780	+710	+710
180 - 200	63	-14	13	61	63	94	161	89	-171	-113	-81	-52	-32	0	20	45	65	85	123	183	121	+121	+200	+280	+390	190	+190	+370	+460	+560	290	+290	+560	+700	+800	+730	+730
200 - 225	70	-15	14	70	70	105	177	97	-186	-126	-91	-60	-38	0	21	48	69	90	130	190	130	+130	+220	+310	+420	200	+200	+390	+480	+580	300	+300	+580	+720	+820	+750	+750
225 - 250	77	-16	15	79	77	115	191	109	-203	-137	-100	-68	-42	0	22	51	73	96	137	200	140	+140	+240	+340	+450	210	+210	+400	+490	+590	310	+310	+590	+730	+830	+760	+760
250 - 280	84	-17	16	88	84	128	207	117	-221	-149	-106	-72	-45	0	23	54	77	100	142	207	150	+150	+260	+360	+470	220	+220	+410	+500	+600	320	+320	+600	+740	+840	+770	+770
280 - 315	90	-18	17	98	90	140	224	127	-241	-163	-116	-78	-48	0	24	58	81	104	148	217	160	+160	+270	+370	+480	230	+230	+420	+510	+610	330	+330	+610	+750	+850	+780	+780
315 - 355	97	-19	18	108	97	150	242	137	-261	-177	-126	-84	-51	0	25	61	84	107	152	221	170	+170	+280	+380	+490	240	+240	+430	+520	+620	340	+340	+620	+760	+860	+790	+790
355 - 400	104	-20	19	119	104	160	261	147	-281	-193	-138	-93	-57	0	26	65	88	111	156	225	180	+180	+290	+390	+500	250	+250	+440	+530	+630	350	+350	+630	+770	+870	+800	+800
400 - 450	110	-21	20	130	110	170	280	157	-301	-207	-148	-100	-61	0	27	69	92	115	160	229	190	+190	+300	+400	+510	260	+260	+450	+540	+640	360	+360	+640	+780	+880	+810	+810
450 - 500	118	-22	21	141	118	180	300	167	-321	-219	-156	-105	-65	0	28	73	96	119	164	233	200	+200	+310	+410	+520	270	+270	+460	+550	+650	370	+370	+650	+790	+890	+820	+820

Appendix

Major SI Unit Conversion Tables Units shown within the bold lines indicate SI units.

Force	N	dyn	kgf
	1	1×10^5	1.01972×10^{-1}
	1×10^{-5}	1	1.01972×10^{-6}
	9.80665	9.80665×10^5	1

Viscosity	Pa·s	cp	P
	1	1×10^3	1×10
	1×10^{-3}	1	1×10^{-2}
	1×10^{-1}	1×10^2	1

Note: $1P = 1\text{dyn}\cdot\text{s}/\text{cm}^2 = 1\text{g}/\text{cm}\cdot\text{s}$, $1\text{Pa}\cdot\text{s} = 1\text{N}\cdot\text{s}/\text{m}^2$, $1\text{cP} = 1\text{mPa}\cdot\text{s}$

Pressure	Pa	kPa	MPa	bar	kgf/cm ²	atm	mmH ₂ O	mmHg or Torr
	1	1×10^{-3}	1×10^{-6}	1×10^{-5}	1.01972×10^{-5}	9.86923×10^{-6}	1.01972×10^{-1}	7.50062×10^3
	1×10^3	1	1×10^{-3}	1×10^{-2}	1.01972×10^{-2}	9.86923×10^{-3}	1.01972×10^2	7.50062
	1×10^6	1×10^3	1	1×10	1.01972×10	9.86923	1.01972×10^5	7.50062×10^3
	1×10^5	1×10^2	1×10^{-1}	1	1.01972	9.86923×10^{-1}	1.01972×10^4	7.50062×10^2
	9.80665×10^4	9.80665×10	9.80665×10^{-2}	9.80665×10^{-1}	1	9.67841×10^{-1}	1×10^4	7.35559×10^2
	1.01325×10^5	1.01325×10^2	1.01325×10^{-1}	1.01325	1.03323	1	1.03323×10^4	7.60000×10^2
	9.80665	9.80665×10^{-3}	9.80665×10^{-6}	9.80665×10^{-5}	1×10^{-4}	9.67841×10^{-5}	1	7.35559×10^{-2}
	1.33322×10^2	1.33322×10^{-1}	1.33322×10^{-4}	1.33322×10^{-3}	1.35951×10^{-3}	1.31579×10^{-3}	1.35951×10	1

Note: $1\text{Pa} = 1\text{N}/\text{m}^2$

Stress	Pa or N/m ²	MPa or N/mm ²	kgf	kgf/cm ²
	1	1×10^{-6}	1.01972×10^{-7}	1.01972×10^{-5}
	1×10^6	1	1.01972×10^{-1}	1.01972×10
	9.80665×10^6	9.80665	1	1×10^2
	9.80665×10^4	9.80665×10^{-2}	1×10^{-2}	1

Note: $1\text{Pa} = 1\text{N}/\text{m}^2$, $1\text{MPa} = 1\text{N}/\text{mm}^2$

Dynamic viscosity	m ² /s	cSt	St
	1	1×10^6	1×10^4
	1×10^{-6}	1	1×10^2
	1×10^{-4}	1×10^2	1

Note: $1\text{St} = 1\text{cm}^2/\text{s}$, $1\text{cSt} = 1\text{mm}^2/\text{S}$

Amount of work, energy, heat	J	kW·h	kgf·m	kcal
	1	2.7778×10^{-7}	1.0197×10^{-1}	2.3889×10^{-4}
	3.6×10^6	1	3.6710×10^5	8.6000×10^2
	9.8067	2.7241×10^{-6}	1	2.3427×10^{-3}
	4.1861×10^3	1.1628×10^{-3}	4.2686×10^2	1

Work rate (efficiency/ power) and heat transfer	W	kgf·m/s	PS	kcal/h
	1	1.0197×10^{-1}	1.3596×10^{-3}	8.6000×10^{-1}
	9.8067	1	1.3333×10^{-2}	8.4337
	7.355×10^2	7.5×10	1	6.3253×10^2
	1.1628	1.1857×10^{-1}	1.5810×10^{-3}	1



© **NOK CORPORATION** Printed in Japan

Overseas Sales & Marketing Department Sales & Marketing Division

1-12-15 Shiba Daimon Minato-ku, Tokyo, Japan. Zipcord 105-8585.

The contents is subject to change without notice.

All compatibility data, application information, design & material information and technical deta in this catalogue are compiled as a reference material to make a basic packing selection.

A selected standard design from this catalogue may not comform to the actual use of an application, clue to unknown factors in the application.

Please comfirm the actual compatibility of a selected product with your application before using it.